

# SHORT WAVE CRAFT

November

WORLD'S  
LARGEST  
SHORT WAVE  
CIRCULATION

HUGO GERNSBACK  
Editor



**XGW 上海**

**(XGW Shanghai Calling)**

**(See Page 394)**

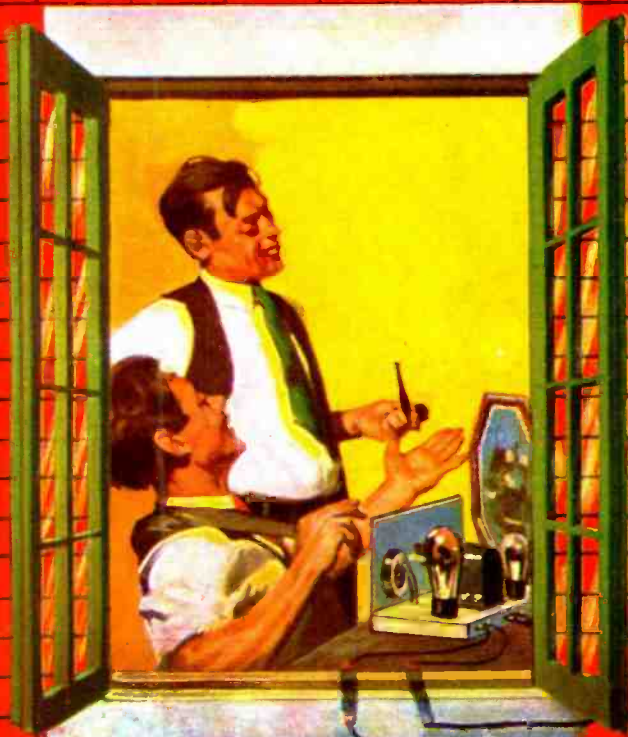

**25¢**  
IN CANADA  
30¢



"MAKE SURE THE RADIO TUBES YOU BUY ARE REALLY NEW"

*radio's big stars urge you ...*



"REMEMBER, FRIENDS, EVEN AN ENGINEER CAN'T TELL A NEW TUBE FROM A USED TUBE. THESE SEALED CARTONS PROTECT YOU AGAINST OLD RADIO TUBES SOLD AS NEW ... AND THAT'S ONLY THE BEE-GINNIN' IT MEANS THAT YOU FOLKS WILL HEAR OUR PROGRAMS JUST AS IF YOU WERE ABOARD THE SHOWBOAT WITH US."

Charles Winniger as CAPTAIN HENRY

## INSIST ON THIS SEALED CARTON

and you are sure of getting genuine Micro-Sensitive RCA Radio Tubes

DON'T be fooled by old worn-out radio tubes palmed off on the public as new. Ask for genuine RCA Radio Tubes that come to you in a sealed, non-refillable carton. They can be tested without removing the carton ... but the carton *must be destroyed* before tube can be used.

These are the tubes guaranteed by the RCA Radiotron Company to give you these five big improvements: (1) *Quicker Start.* (2) *Quieter Operation.* (3) *Uniform Volume.* (4) *Uniform Performance.* (5) *Sealed Carton Protection.*

LOOK FOR THIS SIGN  
In your neighborhood. It identifies a dealer selected by RCA to serve your radio tube needs.



To increase your radio pleasure, ask your nearest authorized RCA Radio Tube Agent for the new Micro-Sensitive RCA Radio Tubes.

### BE CAREFUL



Hundreds of thousands of used radio tubes are being sold as new by dishonest dealers — slipped into new open-flap cartons — so you can't tell the difference.

LISTEN TO THE STARS  
Tune in on Radio City Studio Parry 9 to 9:30, E. S. T., every Saturday night over N. B. C. Blue network. Hear the big stars of your favorite programs — Fun — Music — Quick Flashes from John B. Kennedy, famous commentator



SHORT WAVE CRAFT is published monthly, on the 1st of every month; subscription price is \$2.50 a year in the United States and possessions (in Canada and foreign countries \$3.00 a year to cover additional postage). Entered as second class matter May 7, 1930, at the Post Office at Mount Morris, Ill., under the act of March 3, 1879.



# Be a Radio Expert

## I WILL HELP YOU START A SPARE TIME OR FULL TIME RADIO SERVICE BUSINESS WITHOUT CAPITAL

### Many Make \$40 \$60 \$75 a Week



**J. E. SMITH, President  
National Radio Institute**  
He has directed the training of  
more men for the Radio industry  
by the home study method than any  
other man in America.

#### Broadcasting Stations

Employ managers, engineers, operators, installation and maintenance men for jobs paying up to \$5,000 a year. The larger stations employ as many as 20 to 60 men. Over 600 Broadcasting Stations now in operation.

#### Set Servicing

Spare time set servicing pays many N.R.I. men \$5, \$10, \$15 a week extra. Full time men make as much as \$40, \$60, \$75 a week. Almost every community offers trained men opportunities to enter this profitable field.

The world-wide use of Radio sets for home entertainment—over 18,000,000 in use in the United States today—has opened many opportunities for you to have a profitable spare time or full time Radio service or retail business of your own. I show you an easy, quick way to do most Radio service jobs. The day you enroll I send you instructions for doing 28 Radio jobs common in almost every neighborhood. Many N.R.I. men make \$5, \$10, \$15 a week extra in spare time while learning. I show you how to install and service all types of Radio receiving sets. I give you Radio equipment and instructions for conducting experiments, for building circuits and testing equipment, and for making tests that will give you broad, practical Radio experience.

#### Clip and Mail the Post Card Now

Get my big FREE book, "Rich Rewards in Radio." It gives you a full story of the success of N.R.I. students and graduates and tells you how they start a spare time or full time Radio service business on money made in spare time while learning.

#### Get Ready Now for a Radio Service Business of Your Own and for Jobs Like These

Broadcasting stations use engineers, operators, station managers, and pay up to \$5,000 a year. Radio manufacturers use testers, inspectors, foremen, engineers, servicemen, and buyers, and pay up to \$6,000 a year. Radio dealers and jobbers employ hundreds of servicemen, salesmen, managers, and pay up to \$5,000 a year. Radio operators on ships enjoy life, see the world, with board and lodging free, and get good pay besides. My book tells you of the opportunities in these fields, also in Aviation Radio, Television, Police Radio, Short Wave Radio, Automobile Radio, and other branches of this fast growing industry. Get it.  
*(Continued on other side)*



#### Loud Speaker Systems

Installing and servicing Loud Speaker Systems in auditoriums, for sporting events, political rallies, in schools, factories, railroad stations, etc., is another growing money-making field for Radio trained men.



#### Some Other Jobs N.R.I. Men Train for

Service Business of your own  
Spare Time Service Jobs  
Salesman of Sets and other Radio Equipment  
Service Expert for Stores  
Broadcasting Station Operator  
Aviation Radio Operator  
Ship Radio Operator  
Loud Speaker Systems, Installations and Service

Auto Radio Installation and Service  
Short Wave Transmitter Installation and Maintenance  
Designing and Building Testing Equipment  
Service Expert with Radio Factory  
Commercial Radio Station Operator  
All-around Servicing Expert

PLACE  
ONE  
CENT  
STAMP  
HERE

**J. E. SMITH, President**

**National Radio Institute**

**16th and U Streets N. W.**

**Washington, D. C.**





# Here's Proof that My Training Pays

## BE A RADIO EXPERT

I Will Train You at Home in Your Spare Time

Hold your job until you're ready for another. Give me only part of your spare time. You do not need a high school or college education. Hundreds with only common school education have won bigger pay through N.R.I. J. A. Vaughn jumped from \$35 to \$100 a week. J. E. McLaurine increased his earnings 100 per cent. The National Radio Institute is the Pioneer institution devoted exclusively to training men and young men by home study for good jobs in Radio. Twenty years of experience are behind N.R.I. Training.

Many N.R.I. Men Make \$5, \$10, \$15 A Week Extra in Spare Time While Learning

Many of the 18,000,000 Radio sets now in use are only about 50% efficient. Some are out of date—need modernizing. Many need slight adjustments of tuning circuits—others lack tone quality. Still others need new tubes or need "balancing"—to put them in perfect working order. I will show you how to cash in on these conditions. I will give you the plans and ideas that have enabled many N.R.I. men to make \$5, \$10, \$15 a week in spare time while learning. Ford R. Leary, 1633 Davison Road, Flint, Michigan, writes: "My part time earnings while taking the N.R.I. Course were \$651."

### Money Back Agreement Assures Your Satisfaction

I give you an agreement, in writing, to refund every cent of your money if you are not satisfied with my Lessons and Instruction Service when you complete my Training. And I'll not only give you thorough training in Radio fundamentals, but also **ADVANCED TRAINING** to enable you to specialize in the branch of Radio that suits you best. Read the outline of this Advanced Training and read my Money Back Agreement. Get my **FREE BOOK**.

### Television, Short Wave, Loud Speaker Systems Included

There's opportunity for you in Radio. Its future is certain. In Television, Short Wave, Loud Speaker Systems, Police Radio, Auto Radio, Aviation Radio—in every branch, developments and improvements are taking place. Here is a real future for thousands of men who really know Radio—men with sound, practical N.R.I. Training. Get the Training that opens the road to good pay and success.

### Get My Free Book of Facts—NOW!

Mail the post card below for your **FREE COPY** of my big 64-page book, "Rich Rewards in Radio," which I want to send free to every ambitious person over 15 years old. It tells you all about Radio's spare time and full time opportunities; about my Training; what others who have taken it are doing and making. **MAIL THE POST CARD NOW.**

J. E. SMITH, President  
National Radio Institute  
Washington, D. C.

Find out what **RADIO** Offers

Mr. J. E. SMITH, President  
National Radio Institute, Dept. 4MB3  
Washington, D. C.

Dear Mr. Smith: Without obligating me, send your book which points out the spare time and full time job and business opportunities in Radio and explains your amazingly practical 50-50 method of training men, quickly and inexpensively at home in their spare time to be Radio Experts. (Please Print Plainly)

Name ..... Age .....  
Address .....  
City ..... State .....



**Operator Station KTSA**  
"I am operating Station KTSA. Since I graduated I have operated quite a few stations, in addition to aviation work. My N.R.I. training has been invaluable. I have worked at almost all angles of the Radio game—started out as serviceman, then operator, engineer and pilot." T. L. KIDD, 519 W. Summit Ave., San Antonio, Texas.



**\$55 to \$65 a week**  
"I am doing lots of repair work on the latest model sets, and am getting along splendidly, thanks to you and N.R.I. training. It has surely helped me to get ahead in Radio. The depression did not seem to hurt me. I have been making an average of \$55 to \$65 a week." PETER J. DUNN, 901 North Monroe St., Baltimore, Md.



**With Montgomery Ward \$2,000 to \$2,500 a year**  
"I would estimate my yearly earnings at \$2,000 to \$2,500. I have been with Montgomery Ward for quite a few years—have been able to buy a fine home and a new car. I have advised several to take your Course—men who have since made a big success in Radio." STEPHEN MILLARD, 390 South Dale St., Denver, Colorado.

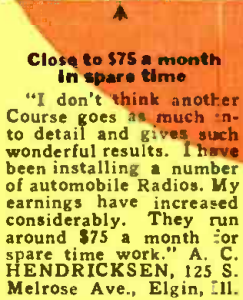

**Close to \$75 a month in spare time**  
"I don't think another Course goes as much into detail and gives such wonderful results. I have been installing a number of automobile Radios. My earnings have increased considerably. They run around \$75 a month for spare time work." A. C. HENDRICKSEN, 125 S. Melrose Ave., Elgin, Ill.

I have Doubled and Tripled the Salaries of Many Get my **FREE** Book • Read about this Tested way to Better Pay • *Mail the post card NOW*

**Rich Rewards in Radio**

**YOU GET PRACTICAL EXPERIENCE With the Radio Equipment I GIVE YOU**

I'll show you how to use my special Radio equipment for conducting experiments and building circuits which illustrate important principles used in such well-known sets as Westinghouse, General Electric, Philco, R.C.A.-Victor, Majestic and others. You work out with your own hands many of the things you learn in our Lesson Books. This 50-50 method of training makes learning at home easy, interesting, fascinating, intensely practical. You learn how sets work, why they work, and how to make them work when they are out of order. Training like this shows up in your pay envelope.

*Mail the post card now!*

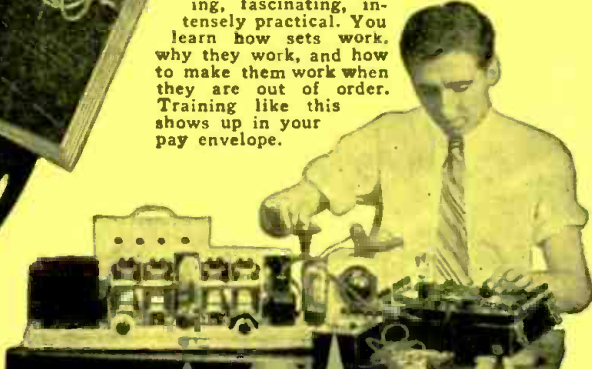



# AND NOW — SUPREME METERS



Supreme Meter \$6.25

Supreme Rectifier \$2.75

Supreme Resistor Kit \$4.00

Out of the thousands of enthusiastic users of Supreme Instruments, many suggestions have been made that the Supreme engineers who have always pioneered the most advanced of tester circuits should also offer an advanced meter in keeping with their tester designs. In order to meet this demand on the part of Supreme users, a new 5-inch meter is now offered in a fan-shaped case with longer scales and larger figures for more consistent accuracy and better readability. Every detail has been carefully considered in the course of its development, and this is probably the first meter designed especially for use in radio testing equipment. Heretofore meters were designed for other purposes and then adapted to radio tester requirements. Supreme engineers have reversed the usual procedure by designing a meter specifically for radio testing instruments.

This meter has a sensitivity resistance of 1000 ohms per volt, with an accuracy tolerance of 2%. It is calibrated for a full-scale current value of 1 milliamper. A dimensional drawing is supplied with each meter which may be used as a template for drilling a panel. The parts kit includes: one meter adjustment resistor, one "Mils" shunt strip, nine special metalized resistors, one "Ohms" shunt strip, one 0-3600-ohm potentiometer, and one Capacitor for output measurements. Complete circuit diagram with resistance values included for building an AC-DC tester with ranges of: Four-range output meter; resistance ranges of 2,000-200,000 ohms D.C. mils of 5-125 mils, A.C. volts of 5-125-500-1250 volts, D.C. volts of 5-125-500-1250 volts.



## RADIO'S BIGGEST VALUE Supreme 333 Standard Analyzer

Here is radio's greatest value. The tremendous popularity and large production of Supreme instruments bring this new model to the lowest price level in history. This entirely new Model 333 Analyzer, featuring Supreme's latest 5" fan-type meter achievement with full vision scale and the exclusive Free Reference Point System of Analysis creates a new standard of value. This new instrument is a combination point-to-point tester and analyzer, providing complete resistance, voltage and current analysis, and tube testing from the radio socket with self-contained battery. All meter ranges, including resistance and output measurements, are applied through the analyzer cable so it is unnecessary to remove the chassis of the radio or dismantle it to gain access to the circuits for point-to-point tests. All meter ranges are selected by a single 12-position rotary switch. The four range output meter requires no adapters but measurements are accomplished by merely inserting the analyzer plug into one of the power output tube sockets and setting a switch for output indications. Meter ranges are: resistance 2,000-200,000 ohms, D.C. mils 5-125 mils, A.C. volts of 5-125-500-1250 volts and D.C. volts of 5-125-500-1250 volts. Large figures are used for markings of the "ohms" range so as to provide easy readability. The low range 0-2000 ohms is very useful for all continuity testing, the first division being 1 ohm with the 35 ohm marking at the center of the scale. The 0-200,000 ohm range meets practically all other servicing requirements. A variable shunt adjustment is provided so that the meter remains very accurate within the useful range of the battery employed. A new tube base selector and Free Reference Point System of Analysis chart is furnished with each instrument in addition to other accessories and complete instruction manual.

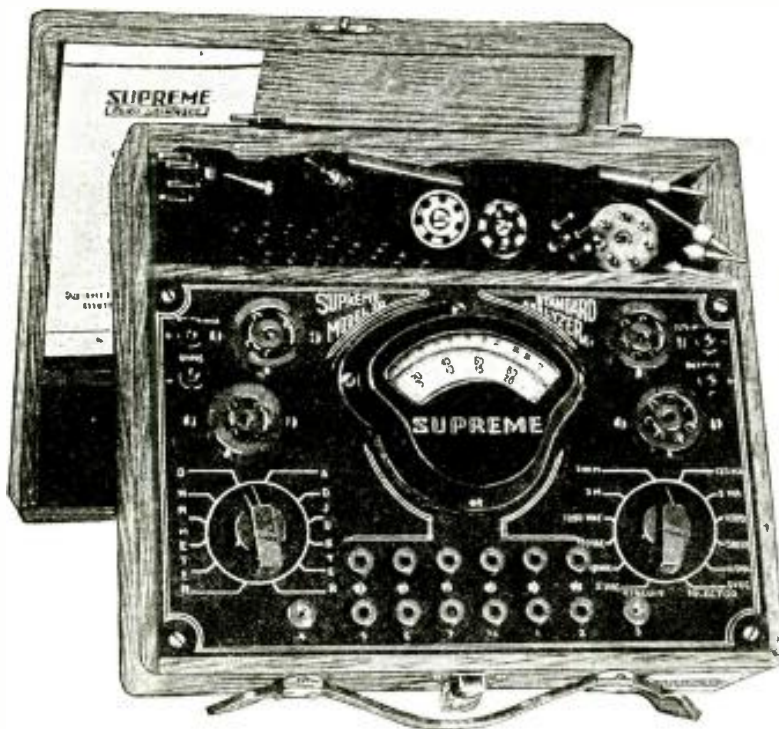

Send coupon below for detailed data and catalog.

SUPREME INSTRUMENTS CORPORATION  
G-1 Supreme Bldg., Greenwood, Miss.

Please send complete detailed Catalog 1935 Supreme Models.

Name .....

Address .....

City ..... State .....

Jobber Preference .....

**IN THIS ISSUE: PROMINENT SHORT-WAVE AUTHORS**  
**Denton . Barnett . Shuart . Woehr . Johnson . Moller**

**HUGO GERNSBACK**  
 Editor



**H. WINFIELD SECOR**  
 Managing Editor

**Contents for November, 1934**

Editorial—"Disappearing Waves," by Hugo Gernsback. 389

What Happens When You Talk to a Ship at Sea, by H. W. Secor..... 391

New 5-Tube Superhet for Battery Operation, by Mander Barnett ..... 392

Our Cover—XGW, Shanghai Calling?..... 394

What the British Are Doing with 5 Meters..... 394

Improving the Victor 2-Tube Superhet, by W. A. Woehr, W9PTZ ..... 395

2 to 5 Meter Set Works Speaker, by George W. Shuart, W2AMN ..... 396

Best Aerial for "Europeans," by Heinie Johnson..... 398

How to Tune In Short Waves on "Broadcast" Set, by J. F. Roese..... 398

More Power on 2.5 Meters with Triodes, by George W. Shuart, W2AMN..... 399

World-Wide Short-Wave Review, edited by C. W. Palmer 400

SHORT WAVE SCOUT News..... 402

SHORT WAVE SCOUTS—Award of Ninth Trophy for Best Station "Log" to Florian Poeschal..... 403

SHORT WAVES AND LONG WAVES—Our Readers' Forum ..... 404

Which Audio Amplifier Should I Build? by Clifford E. Denton ..... 406

3.1 Meter Receiver, by Dr. W. Möller. .... 408

"Break-in" Monitoring, by Donald McKinley, VE3AU. 409

A Home-Made Condenser "Mike"..... 409

What's New in Short-Wave Apparatus..... 410

SHORT WAVE STATIONS OF THE WORLD, Complete List, Including "Police" and "Television" Stations, edited by M. Harvey Gernsback..... 415

SHORT WAVE LEAGUE..... 419

\$5.00 Monthly for Best Short-Wave KINK..... 420

Short Wave QUESTION BOX..... 421

WHEN TO LISTEN IN, by M. Harvey Gernsback..... 428

**Certified Circuits**



● **SHORT WAVE CRAFT** goes to a large expense in verifying new circuits published in this magazine. Whenever you see the seal shown here in connection with any of the sets published in this and future issues of **SHORT**

**WAVE CRAFT**, this will be your guarantee that this set has been tested in our laboratories, as well as privately, in different parts of the country to make sure that the circuit and selected parts are right. Only "Constructional-Experimental" circuits are certified by us.

When you see our certificate seal on any set described you need not hesitate in spending money for parts, because you are assured in advance that the set and circuit are bona fide and that this magazine stands behind it.

**SHORT WAVE CRAFT** is the only magazine that thus certifies circuits and sets.

**OUR COVER**

● **OUR** front cover illustration this month shows the happy moment when a short-wave "fan" thinks he has just landed a prize station—XGW, Shanghai. But perhaps his brother "fan" on the floor above had something to do with it—Read all about it on page..... 394

COPYRIGHT, 1934, BY H. GERNSBACK

Published by **POPULAR BOOK CORPORATION**

HUGO GERNSBACK, President - - - H. W. SECOR, Vice-President  
 EMIL GROSSMAN - - - Director of Advertising  
 Chicago Adv. Office - - - L. F. McCLURE, 919 No. Michigan Ave.  
 Publication Office - - - 404 N. Wesley Avenue, Mount Morris, Ill.  
 Editorial and General Offices - - - 99-101 Hudson St., New York, N. Y.  
 London Agent: HACHETTE & CIE., 16-17 King William St., Charing Cross, W.C.2

Paris Agent: HACHETTE & CIE., 111 Rue Reaumur  
 Australian Agents: MCGILL'S AGENCY, 179 Elizabeth St., Melbourne

**Features in December Issue**

- A Real S-W "Pocket" Receiver—It Picked Up "European" Stations in Actual Tests.
- Simplified Radio Control for Directing Model Boats, Planes, etc., by Rex E. Lovejoy.
- A Low-Powered DeLux Transmitter for the Ham, by Gerrald A. Swank.
- Short-Wave Receivers in "Book" Form, by Heinie Johnson.
- A Separate "Regeneration Tube" Receiver, by George W. Shuart, W2AMN.
- The Latest in 5 Meter Sets.

**SHORT-WAVE CRAFT**—Monthly. Entered as second class matter May 7, 1930, at the post office at Mount Morris, Illinois, under the act of March 3, 1879. Trademarks and copyrights by permission of H. Gernsback, 99-101 Hudson St., N. Y. C. Text and illustrations of this magazine are copyrighted and must not be reproduced without permission. **SHORT WAVE CRAFT** is published on the 1st of every month. Twelve numbers per year. Subscription price is \$2.50 a year in the United States and possessions. Canada and foreign countries, \$3.00 a year. Single copies 25c. Address all contributions for publication to Editor, **SHORT WAVE CRAFT**, 99-101 Hudson St., New York, N. Y. Publishers are not responsible for lost manuscripts. Contributions cannot be returned unless authors remit full postage. **SHORT WAVE CRAFT** is for sale at all principal news-stands in the United States and Canada. European agents: Brentano's, London and Paris. Printed in U. S. A. Make all subscription checks payable to Popular Book Corporation.



**By Doing Actual Jobs — No Correspondence — On Modern Radio Equipment**



View of Students operating our Television Camera and Scanning Unit

**TRAIN  
in 10 Weeks  
in the big  
Chicago Shops  
of Coyne**



Students operating our modern Transmitter

**TELEVISION**

# FOR RADIO

**TALKING PICTURES**

**No Advanced Education or Previous Experience Needed  
to Master Thorough, Practical Coyne Training**

The remarkable "Learn by Doing" methods used in the great Coyne Shops in Chicago, Train you to easily master Radio and its many branches. Coyne doesn't teach you by correspondence—You don't study from books—You don't get lessons in a classroom—You don't have to recite—instead, you are trained right in the wonderful, modern, daylight shops on the finest kind of Radio, Sound and Television equipment under the personal supervision of expert instructors. You get individual instruction and only do the sort of work you will meet out in the field on a real job. That's why Coyne Practical Training is able to prepare you in such a short time. Spend only 10 weeks doing actual work on Radio equipment worth many thousands of dollars and you should be ready to qualify for a big pay job. Do radio wiring and testing, trouble shooting, repairing and servicing. Get valuable practical experience by working on a wide variety of modern, up-to-date A. C. Superheterodyne sets, oscillators, analyzers and test instruments. Learn how to operate television receiving and transmitting equipment; to install, test and service public address systems and sound picture equipment. Coyne Training further prepares you for Amateur Broadcast, or Telegraph Radio Operator's License and to know all code and Dept. of Commerce rules for a government License Examination.

*Amazing Offer!*

**PAY FOR YOUR TRAINING AFTER YOU GRADUATE  
in Small Monthly Payments!**

NO RED TAPE—NO STRINGS TO MY OFFER—YOU RUN NO RISK! I'LL TRAIN YOU IN MY SHOPS FOR 90 DAYS—YOU GET OVER ONE YEAR TO PAY YOUR TUITION AFTER YOU HAVE GRADUATED! Make your first payment 60 days after you have finished your 10 weeks' Training period, and then you have

over a year to make the small, monthly payments. Your earnings should make it easy for you. I'm willing to back you in this way because hundreds of my successful graduates have proved to me that the fellow who wants to improve himself and his conditions is the finest credit risk in the world.

**Earn Living Expenses While You Are Training!**

Don't let shortage of cash hold you back. Come to Coyne and you will find me willing to help you. Many of my students work part time to help pay their living expenses while training in the great Coyne Chicago Shops. My Employment Department will also assist you to find a spare time job to cover a good part of your room and board expenses.



**Our Great Shops**

This is our fireproof, modern home wherein is installed thousands of dollars worth of Radio Equipment of all kinds.

H. C. LEWIS, President

**Coyne Electrical School**

Founded 1899

500 S. Paulina St., Dept. 84-2K Chicago, Ill.

**ELECTRIC REFRIGERATION and AIR CONDITIONING COURSE**

**Included Without Extra Cost**

The fastest growing industries in America today. Manufacturers and Distributors of Refrigeration and Air Conditioning equipment need Trained men who have Specialized in these rapidly expanding fields. Here at Coyne you will prepare to fill a job as Installation and Service Man, Shop Mechanic, Tester, Assembler, Inspector, etc. You will learn about various types of compressors, condensers, temperature control devices, thermostatic and expansion valves—you will do actual work on latest types Refrigerating and Air Conditioning machines. And, it won't cost you one extra cent to get this remarkable Training. I include it without charge with your regular Radio Training.



**You Get Employment Help After You Graduate**

My Graduate Employment Service will give you real employment help. As one of my graduates you will get assistance quickly, and every help we can give you to locate a job for which you have been Trained.

**Mail The Coupon**

Get the new "Coyne Opportunity Book" giving all facts about Coyne Training. Photographs of Shops showing students at work on modern Radio equipment under the personal supervision of Coyne Expert Instructors. Also details of my Spare Time Employment Offer, Pay After Graduation Plan and Graduate Employment Service. Yours without cost. Simply mail the coupon.

H. C. Lewis, President  
Coyne Electrical School, Dept. 84-2K  
500 S. Paulina St., Chicago, Ill.

Send me your Big Free Book about Coyne Training and give me all details regarding your Spare Time Employment Offer and Pay After Graduation Plan of easy, monthly payments.

NAME \_\_\_\_\_  
ADDRESS \_\_\_\_\_  
CITY \_\_\_\_\_ STATE \_\_\_\_\_

# Indispensable

say these Short Wave fans—

<p><b>"CLASSIEST BOOK"</b></p> <p>Gentlemen— Your "Official Short Wave Manual" just received. It is the classiest book I have seen for a long time, a fine binding, very good paper, good readable printing and diagrams. Who could ask for more?</p> <p>It was well worth waiting for.</p> <p>Many thanks.</p> <p>(s) H. H. PEBBLES, 6512 Carnegie Avenue, Cleveland, Ohio.</p>	<p><b>"WOULDN'T TAKE \$10.00 FOR IT"</b></p> <p>Gentlemen— I received my copy of the OFFICIAL SHORT WAVE RADIO MANUAL (and autographed too) this morning. I have just finished looking it over, and say I wouldn't take a ten-spot for it. Everything a ham could want between the two covers. I certainly am satisfied with my copy and know everyone else who gets one will be satisfied and proud too.</p> <p>I am sure that this is the finest and most up-to-date book out, and consequently would like all of it.</p> <p>Very truly yours, (s) LOUIS SCHMIDELBECK Beaver Dam, Wis.</p>	<p><b>"WORTH MORE THAN YOU ASK FOR IT"</b></p> <p>Dear Mr. Gernsback: I am in receipt of the 1934 OFFICIAL SHORT WAVE RADIO MANUAL, and wish to state after looking it over I think it is one of the finest Manuals I ever saw published on Short Waves, and I certainly wish to congratulate you on your effort of compiling such a fine Manual. It is sure filled full of good Radio Material, and I am proud of my Manual.</p> <p>It is worth quite a bit more than what you ask for it.</p> <p>FERREL THOMAS, 1528 Locust Street, St. Louis, Mo.</p>	<p><b>"GLAD TO OWN ONE"</b></p> <p>Gentlemen— I received my "SHORT WAVE RADIO MANUAL" and it is a real joy to read and study the book. I waited long for it, but it was worth waiting for.</p> <p>I am introducing it around to all of my friends, and I am glad to own one of these books.</p> <p>Yours respectfully, (s) VINCENT KRAJNAK, 100 West 119th Street, New York City.</p>
--	--	--	---

## WORLD'S GREATEST SHORT WAVE BOOK!

We are proud to present the first modern and complete book on Short Waves which has appeared in the field. There has been a big boom in short waves during the past two years in spite of the depression. Tremendous progress has been made, but up to now there has not been an adequate book depicting all the progress that has been made. The 1934 OFFICIAL SHORT WAVE RADIO MANUAL now fills this need completely.

It is a big book in which you will find everything on short waves, regardless of what it might be. It is not only a complete manual, but a veritable encyclopedia of facts, information, hookups and illustrations. Lack of space does not permit a complete description of this comprehensive volume.

The Manual has been edited by Hugo Gernsback, Editor of SHORT WAVE CRAFT, and H. W. Secor, Managing Editor. If you are a reader of Mr. Gernsback's other publications, you know just about what to expect from this book—his greatest effort in the short-wave field.

**\$2.50**  
List

## 15 VALUABLE FEATURES

- A large section featuring the most important Short-Wave Receivers and how to construct them.
- Short-Wave Transmitters in all their phases.
- A complete Ultra Short-Wave Section featuring construction of 1, 3, 5 and 10 meter receivers.
- A complete Short-Wave Beginner's section. These vary from 1 to 7 tube receivers.
- A section devoted exclusively to coil winding with all information about it.
- A section on Commercial Short-Wave Receivers. Every important commercial receiver, including all-wave sets, is represented. Full servicing data is included which makes it invaluable for Service Men.
- A section devoted to A.C. Short-Wave Power Packs and how to build them.
- A section for the Short-Wave Experimenter and short-wave kinks—hundreds of them.
- A section on the important new art of Short-Wave Therapy (treatment of diseases by short waves).
- A section devoted to Short-Wave Converters and their construction. Full servicing data on all commercial models is included.
- A special section on Short-Wave Antennae and noise eliminating procedures.
- A section on Short-Wave Superheterodynes. This section tells how to build them, including many commercial models of receivers. The latter with complete service data.
- A section on Amateur 'Phone Transmitters and how to build them.
- A Short-Wave Physics section on theoretical short-wave data for the advanced experimenter and radio student.
- A most interesting section on Super-Regeneration in Short-Wave Receivers.

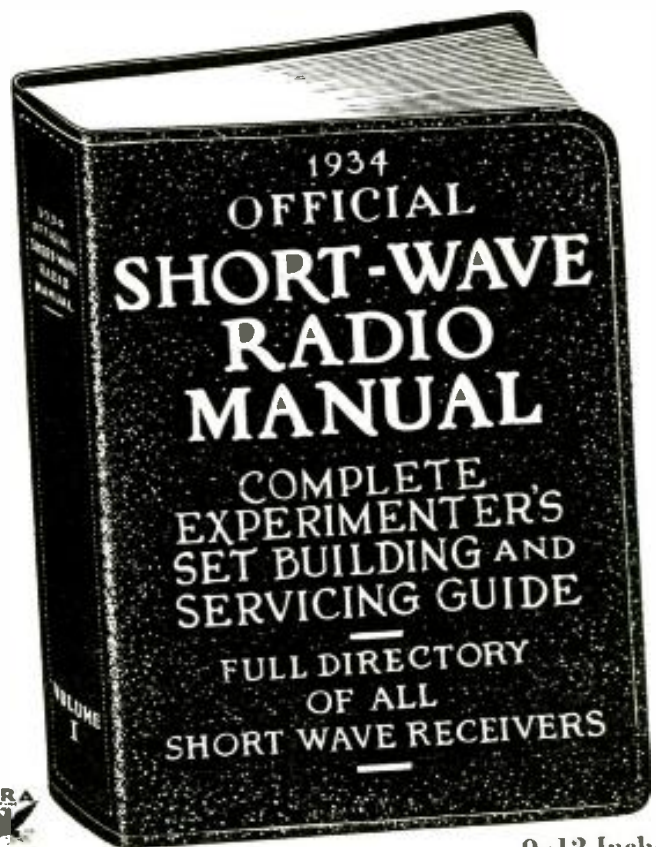

9x12 Inches

Over 240 Big Pages—Over 1,000 Illustrations  
Flexible, Looseleaf Leatherette Binder

Published by

**SHORT WAVE CRAFT**  
99-101 Hudson Street New York, N. Y.

CLIP AND MAIL COUPON!

SHORT WAVE CRAFT,  
99-101 Hudson Street, New York, N. Y. Dept. SWC 11-34

Gentlemen: I enclose herewith my remittance of \$2.50 for which you are to send me, POSTAGE PREPAID, One Copy of the 1934 OFFICIAL SHORT-WAVE RADIO MANUAL. (Send remittance in check or money order. Register letter if it contains cash, stamps or currency.)

Name .....

Address .....

City..... State.....





## Disappearing Waves

An Editorial By HUGO GERNSBACK

● MOST short-wave listeners are aware of the fact that radio reception from foreign countries is not uniformly the same all year round, nor, for that matter, from week to week, or from day to day. One night the stations may come pounding in like locals, when next week it will be impossible to even pick up the carrier with the same set under like conditions. There is, in other words, today, no certainty that the listener can tell in advance that he will be able to get a certain foreign station on any pre-arranged day.

What causes these "disappearing" waves, and why? Is not the action of the waves the same all year round? No exact answer to this can be made at the present time, because there are many factors that may have something to do with it, a number of which we know nothing about.

It is expected that sunspots have something to do with short-wave vagaries. Sunspot activity means that tremendous electro-magnetic forces are set up in connection with these spots. These so-called sunspots are holes in the surface of the sun, and some of these holes or vortices are frequently large enough to drop several bodies the size of the earth into the hole. Some of them measure as much as three and even four times the diameter of the earth across. A tremendous amount of electrical energy is radiated by these sunspots, and the electrical particles bombard the earth at intervals. These solar electronic storms have an effect on the Heaviside layer in the upper strata of our atmosphere, and this interferes with the radio wave propagation. It is believed that when the Heaviside layer shifts or raises up, that this has something to do with the absorption of the short waves. Very exact data on this, however, is missing.

Another cause which has, as yet, to be sufficiently investigated, may be the *cosmic rays*. Just what the action of the cosmic rays is on the earth's atmosphere, the Heaviside layer, and the earth itself, is not known. It is certain, however, that the cosmic rays must have some effect, and it would seem plausible that short waves are affected by these rays. We will know more about this in the years to come.

The moon, also has some effect on short waves, and this has been frequently reported by radio listeners. Exactly what this effect is and whether the moon has any direct bearing on the disappearing of short waves is, as yet, not known.

At the present time, there is considerable activity going on in connection with the so-called "radio echoes." It was observed a few years ago that the signals from certain sta-

tions were heard the same as customary, but then a second signal of identically the same character was received several minutes later—a *radio echo*, in other words. Inasmuch as radio waves travel at the rate of 186,000 miles per second, no body in the vicinity of the earth could account for this reflection of the radio waves, and it seems conclusively proven that a reflecting layer of some sort must exist millions of miles away from the earth. Just exactly what this reflecting layer is, has, as yet, not been made clear. It is certain, however, that it is of an electrical nature. For want of a better name, I may call it an *electrical cloud*. Just what this electrical cloud is, whether it has something to do with cosmic rays, or whether it is a combination of cosmic ray and electro-magnetic particles sent down from the sun due to sunspots, is only surmised. I can, however, imagine that an electrical body composed only of electrical charges can well exist independently in space. I make this assumption from the experience we have had on earth in connection with *ball lightning*.

*Ball lightning* is a pure concentrated electrical charge which travels not at all like ordinary lightning, at the speed of light, but is usually a ball composed of some form of electricity in the shape of a luminous sphere. Such ball lightning is frequently observed. A ball the size of a child's head may come in through the window, or it may come down the chimney and usually floats leisurely through the air, and then for no accountable reason explodes, with a loud noise, often killing people or cattle, or both. A similar electrical charge in the form of a cloud or sphere may conceivably exist somewhere in space, independent of the earth or any of the planets. When a radio wave strikes such a body, it is conceivable that it might be reflected. There is also no telling what effect such an electrical cloud may have on our own atmosphere and the Heaviside layer, but the radio echoes are proof that something of this type must exist. Further research may throw more light on this question.

Of course, when we say that the radio waves disappear, we do not mean by this that they disappear altogether. For instance, our commercial radio stations, which have a number of listening stations tied together, and which use far greater power in reception than the average radio listener, are not quite as conscious of the *disappearing waves* as the average listener, but even they experience a rather strong reduction of the signal's intensity, all of which tends to show that something certainly happens to it between the transmitter and receiver.

---

**SHORT WAVE CRAFT IS PUBLISHED ON THE 1st OF EVERY MONTH**

This is the November, 1934, Issue—Vol. V, No. 7. The Next Issue Comes Out November 1st

---

Editorial and Advertising Offices - 99-101 Hudson Street, New York City



# “SHIP-TO-SHORE” Phone Picturized

Whether or not you have spoken to or from a ship at sea, you will be interested in the accompanying picture story and the description on the opposite page, which help to clarify the marvelous short-wave engineering accomplishment here exemplified.

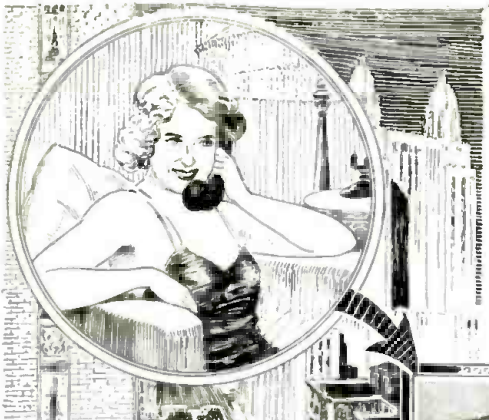

You may sit in the comfort of your home on land and talk to a person on the high seas bound for Europe.



Right — Passenger aboard the S.S. “Leviathan” talking to a telephone subscriber on land. 21 ships are now fitted with radio-phones and can be contacted by land subscribers anywhere in the country.

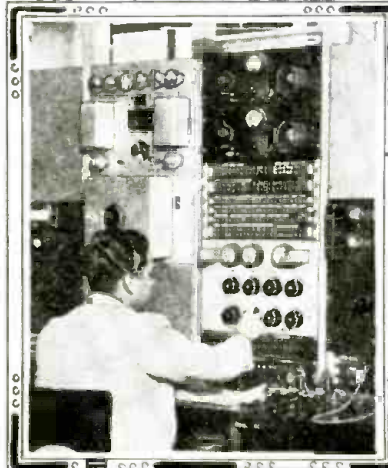

Above — Over-Seas switchboard operators who handle the “incoming” and “outgoing” phone calls between ships and land subscribers. Photo at left—One of the technical operators in the A. T. & T. Co. Building, New York City, who has technical supervision over calls.

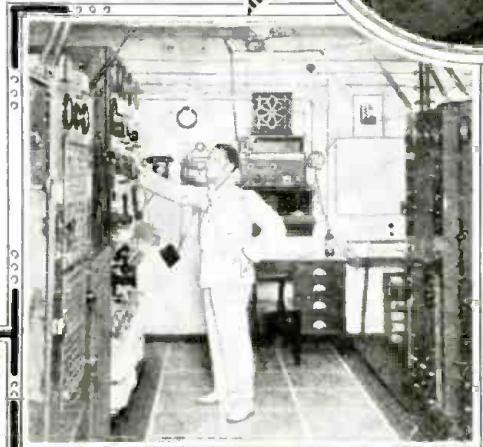

Left—Typical phone transmitter aboard 21 ships now sailing the Atlantic and fitted for carrying on radio phone traffic with subscribers on land. This transmitter is that aboard the S.S. “Empress of Britain.” Receiver below on “De France”.

Photo, right, shows the elaborate short wave receiving antenna at Forked River, N. J. Here the voice waves are picked up from ships.

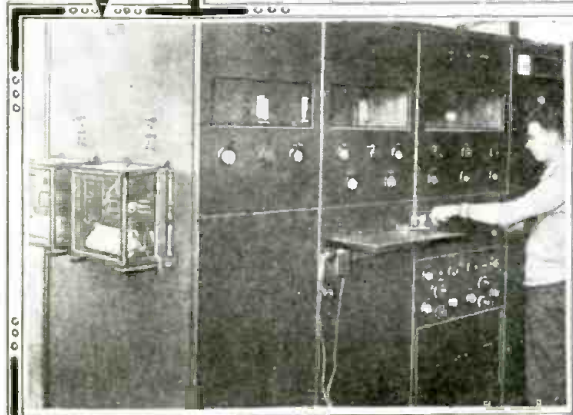
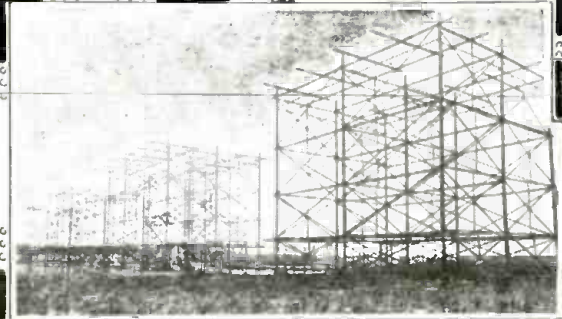

The land transmitter at Ocean Gate, N. J. Right — One of the power tubes. An elaborate antenna and feeder system is used in conjunction with the transmitter. Different aereals for various frequencies are employed.

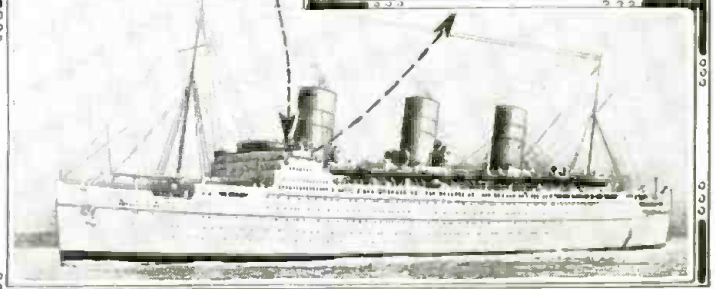
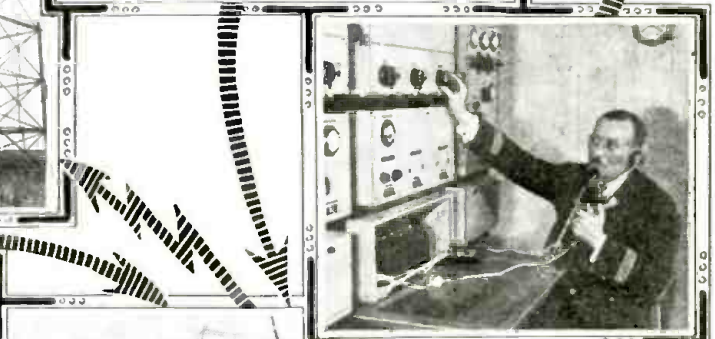

Above—The magnificent steamship, “Empress of Britain”, which handled telephone calls with New York and San Francisco all during her 25,000 mile journey around the world.

Photos courtesy A. T. & T. Company.



# WHAT HAPPENS When You Talk to a Ship AT SEA

By H. W. SECOR

• YOU can now talk by radiophone to twenty-one ships which sail the Atlantic between this country and Europe, and people who have used the Ship-Shore phone service, now a regular twenty-four hour daily service —thanks to *short waves*

—have probably often wondered just what transformations the human voice passed through on its way to or from a ship at sea.

The writer recently had the pleasure of talking by short-wave radio-phon over the service given by the American Telephone and Telegraph Company with the German steamship—*Bremen*. The voice of the chief operator aboard the ship was perfectly steady and clear and it is a very thrilling experience indeed to think that you may now talk to a person aboard ship located practically anywhere along the 2,700 mile expanse of water separating Europe and America. The writer's conversation with the *S.S. Bremen* spanned a distance of 1,400 miles, the ship at the time being approximately in mid-ocean and in a severe wind and rain storm, while the sun was shining brightly in New York. Let us briefly consider the successive stages through which a telephone subscriber's conversation passes as he sits in his hotel or apartment in New York City and talks to possibly his wife or business partner on board a ship on the high seas.

### Arranging for "Call" to the Ship

Ordinarily the person who wishes to make a call to a ship at sea calls Long Distance and is connected with the *Overseas* switchboard located at 32 Sixth Avenue, New York, in the A. T. & T. Company's building. Unless the circuit with the ship desired is being used for traffic at the moment, it is necessary for

Today you can talk by radiophone to or from any one of twenty-one ships traversing the Atlantic Ocean, thanks to the marvelous development of short waves in the past few years. The voice-operated relay that switches the transmitter and receiver circuits for two-way conversation is described; also the successive stages through which your voice passes before leaping out to sea. The ship's radiophone equipment is also described.

the Overseas operator to consult her schedule of the various ships to see what time contact is due with the ship concerned. Of course, if the ship is being "worked" at the time and traffic is light it is frequently possible to put through a call in a few minutes. Radio transmission conditions, sometimes preclude the possibility of the call being put

say, the *S.S. Bremen*. The technical control operators have beforehand called the *Bremen* (by code, on modulated C.W.), on the particular wave-length best suited for that time of day and distance of the ship at sea, and have verified that conditions

are right by a brief exchange of words with the ship's technical operator.

Let us assume you have started talking to a passenger aboard a ship: your voice, or rather the fluctuating electric currents representing your voice, pass over telephone wires to the *Overseas* switchboard, from which point they pass along another telephone circuit to the *technical* control board, located in the same building; from this control panel your voice passes onward with the speed of light to the powerful radio-phon transmitter located at Ocean Gate, N. J. You will probably be interested at this point in knowing that the incoming voice from the person aboard ship is picked up on short waves at the *shore-ship* special receiving station located at Forked River, N. J., the incoming voice passing through the same *technical control* and *overseas operator's* switchboards as the transmitted voice.

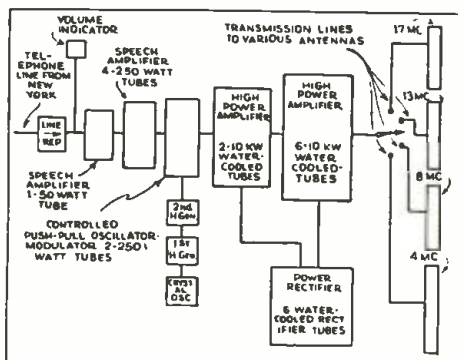

Simplified diagram of phone transmitter circuit used at land end of shore-to-ship radiophone "circuit."

### Voice Operates Relay to Switch "Talk" and "Receive"

Two very remarkable devices, perfected by the radio and telephone engineers responsible for this shore-ship radiophone service, take charge of your voice after it leaves the *technical operator's* control board. Located close to his switchboard there is a large amplifier panel, in which vacuum tubes basically similar to the type used in your radio receiver, amplify the voice currents which then pass into a *time delay* panel comprising a series of resistor and

(Continued on page 422)

through at the expected time. In such rare instances the call is postponed until conditions improve and the subscriber or ship's passenger is notified accordingly.

Suppose you are now ready to talk to the person aboard ship; your telephone bell rings and the *Overseas operator* asks if you are ready to talk to, let us

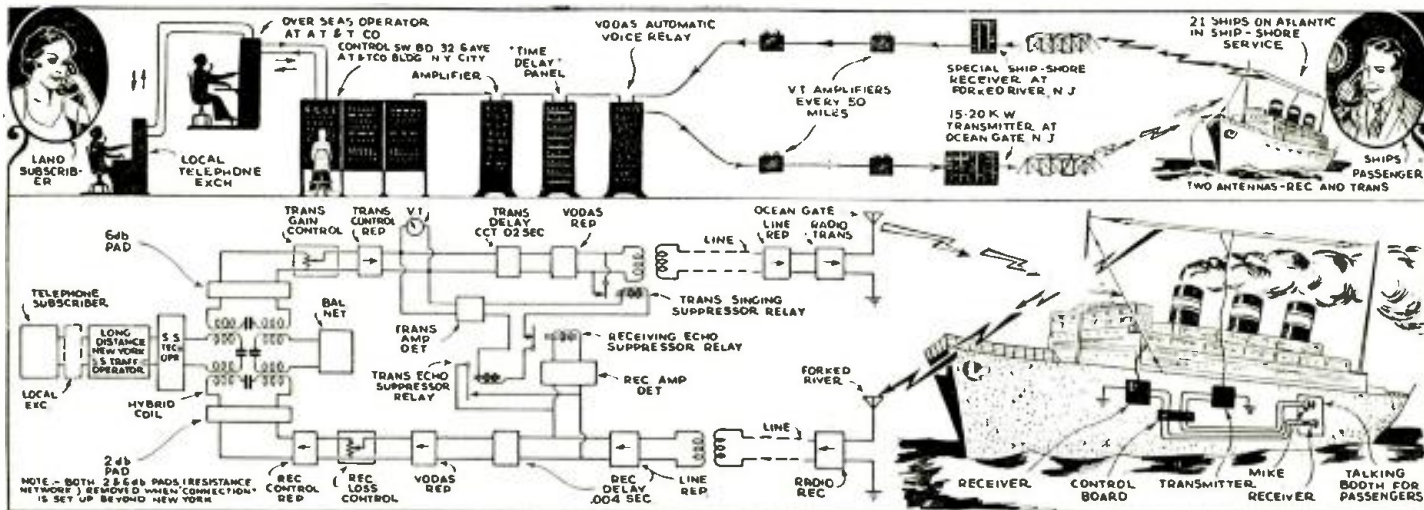

This diagram shows, in simplified fashion, the "set-up" of the land and ship apparatus to carry the human voice both ways between ship and shore. Short waves are used and a different frequency is employed for transmission and reception.



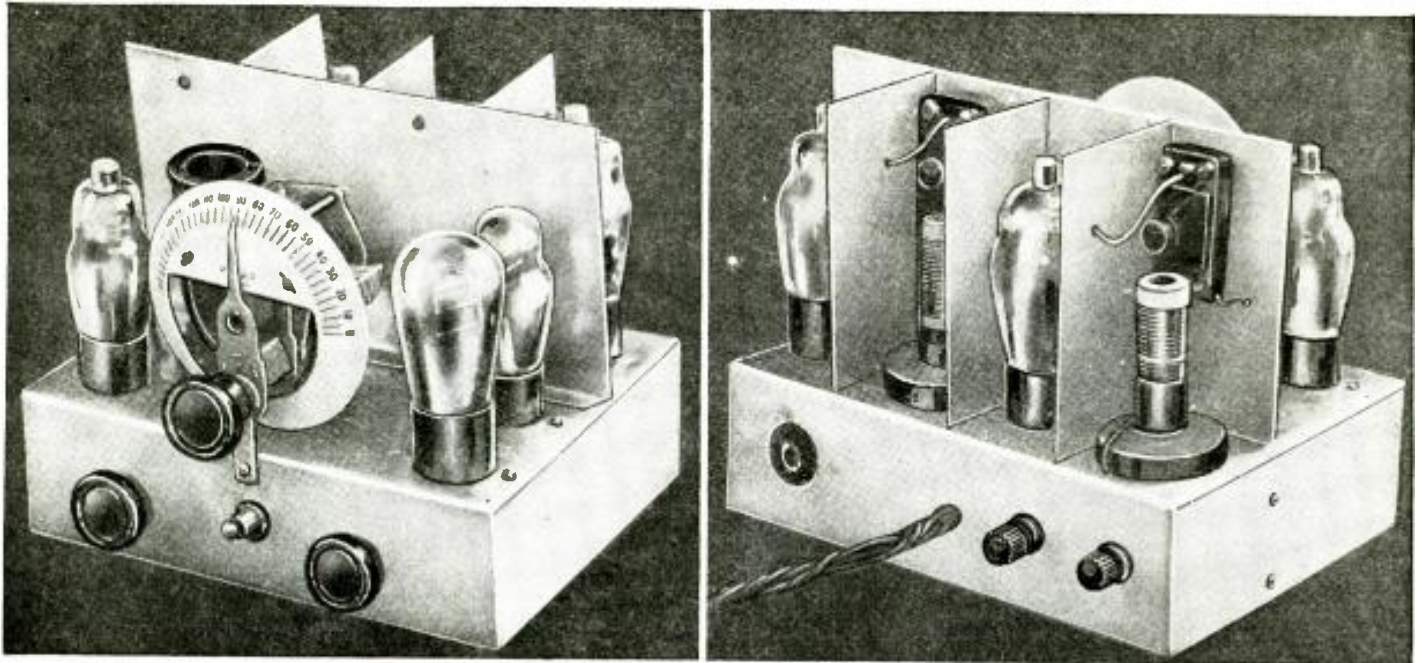

Front and rear views of the 5-tube superhet—full constructional details are given herewith by the author, even to the winding of the I.F. coils.

# New 5-Tube Super-het For Battery Operation

By MANDER BARNETT, England

One of the leading English short-wave exponents here describes a very interesting 5-tube superhet receiver, designed to use standard 2-volt battery tubes. The set is very efficient, using but .44 ampere while the plate current is only 25 ma. Complete data is given for winding the I.F. and other coils. This set features regeneration in the second detector stage and has brought in American short-wave stations in England on a loud-speaker.

peres, according to the actual amount of "C" bias used. This receiver is essentially home-made, right down to the intermediate frequency transformers, and the experimenter or short-wave listener who has had some experience with a two or three-tube short-wave receiver will find this set just right when something larger is required.

Apart from the I.F. stages, there is but one tuned circuit in the whole receiver and a ganged condenser is not used, so there are no trimming or padding condenser troubles to be encountered. On the other hand, *selectivity* is good and the *sensitivity* extremely high. The 1A6 is an excellent short-wave mixer and has the added advantage that it does not permit re-radiation from the

● SHORT-WAVE superheterodyne receivers for battery operation appear to have received less attention in the past than they really deserve, most short-wave receivers built by experimenters and short-wave listeners for use with batteries being generally of the "straight" type, with or without amplification at radio frequencies and employing two to four tubes. This is rather surprising, because a battery-operated super can be really good and although the results per tube will not compare quite so well with receivers using A.C. tubes, a *really powerful* short-wave super for battery use can be built with no more than five tubes. The set to be described here is first and foremost a *short-wave* receiver and will find its greatest use with the experimenter who likes to use a separate receiver for short-wave work and to leave the *broadcast* receiver free for the family to twiddle the knobs.

There's a great advantage in a separate receiver, because while the family is listening to the program on the *broadcast* band, you can be up in the "shack" listening to the *short-wave* stations and, incidentally, listening to programs which do not contain any advertising.

### Low Battery Drain

This receiver uses the latest type tubes in the 2-volt class, including the 1A6 frequency changer and is extremely easy on battery consumption. The total filament current for all five tubes comes to only .44 ampere, while the average "B" current will be somewhere about 25 milliam-

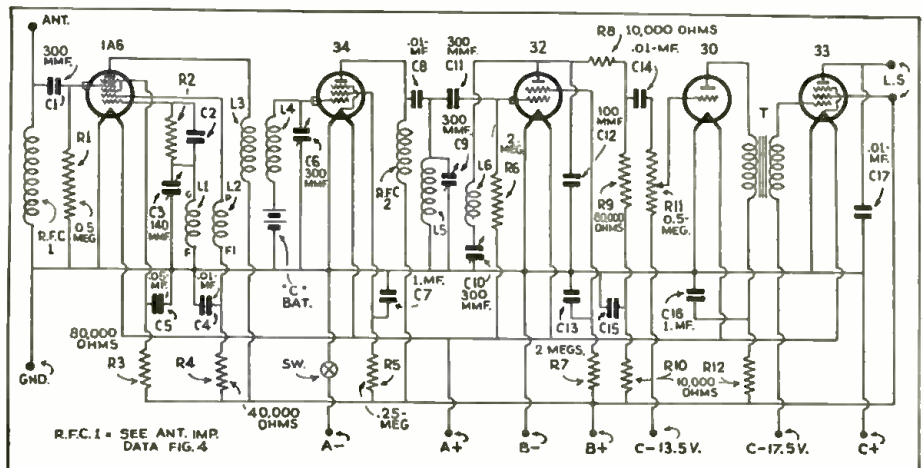

Simple wiring diagram for Mr. Barnett's 5-tube superhet designed for use on American 2-volt battery type tubes.



antenna circuit. The input circuit to the mixer is untuned and consists of a special choke, R.F.C.1, plus the condenser, C1, and resistance, R1. A grid-leak detector arrangement is successfully used instead of a bias detector, thus permitting of a high sensitivity. The whole of the tuning is carried out by the oscillator condenser, C3, in conjunction with plug-in tuning coils, L1 and L2, which are of the standard type using four-pin tube base sockets.

**400 Kc. I.F. Used**

Despite the fact that the input circuit is untuned, exceedingly few "birdies" or image frequency whistles are to be heard on the short waves. An intermediate frequency of about 400 kilocycles is used and although a higher frequency would have some advantages, the extra amplification obtained at the lower frequency is well worth while having. Actually the I.F. stages may be set to a point free from local interference as they are variable over quite a wide range of frequencies, i.e., from about 350 to about 650 kilocycles. From the anode of the 1A6 tube, the I.F. signals are fed through the first I.F. transformer, of which the secondary winding is tuned by a pre-set condenser of .0003 mf. maximum capacity. A type 34 pentode is used in the I.F. amplifying stage, this tube being parallel choke-fed to the second detector, a 32 screened-grid tube, where the single tuning coil, L5, is again tuned by a pre-set condenser of .0003 mf. maximum capacity. Regeneration is applied at this point, to boost signals and to make the reception of C.W. stations possible. A single triode type 30 and 33 pentode output tube, form the audio side of the receiver and provide sufficient "bump"

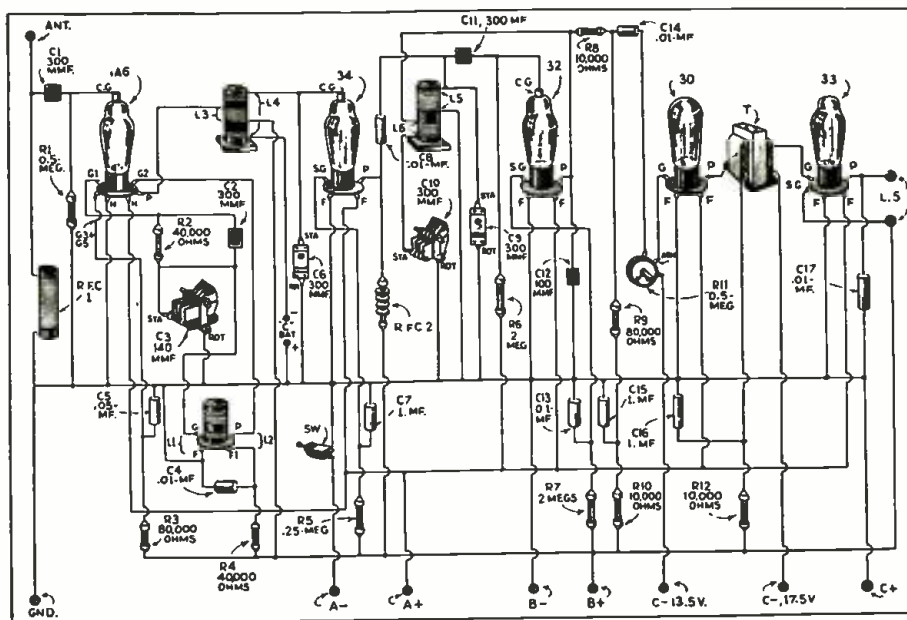

This 5-tube superhet would make a dandy portable short-wave receiver and the picture diagram above makes it a very simple matter to build one.

to shake the speaker diaphragm and to fully load a dynamic speaker on many stations. At this point it is worth mentioning that the writer has not yet detected any suspicion of *body capacity* effects with this receiver on any wavelength and it is completely stable in use.

**Shielding**

As will be seen from the photographs, the receiver is quite compact, but on the other hand it is not so small as to require the hands of a conjurer to wire it up

and to assemble the parts. The metal chassis measures approximately 9" long x 6 1/2" x 2 1/2" deep. The shielding at the back of the chassis houses the I.F. coils and the I.F. amplifier and second detector tubes. If the reader prefers to use commercial intermediates, the method of shielding used here can be dispensed with, the transformers and tubes being mounted so that the transformer screening cans shield each tube separately. In any case it will be advisable

(Continued on page 437)

**Stop Graying Hair**

By WILLIAM H. FRASER

● YOU contracted a touch of that sinister malady *shortwaveitis* and foolishly thought it would pass off . . . that you would recover after throwing the radio magazine behind the bookcase.

But constructional and operative complications set in and your relapse was complete when you found the magazine, and grimly determined to try your hand at that "how-to-make-it" article telling how easy it was for anyone to build for himself the two-tube *Pacific Skipper* receiver. You would soon find out what this crazy fad was all about anyway.

Oddly enough, it was only some twenty

minutes later that you chanced to unearth baby sister's dime bank, from which you floated a loan of \$8.30, leaving intact one world-scarred dime—it wouldn't do to rob the kid outright.

Hurrying to purchase the kit of parts from the list you had copied (including the solder, but forgetting the socket for the plug-in coil) you pondered over what Fate and the foreign broadcasters might have in store for you. With a twinge of fear you recalled the appearance of several short wave addicts you had seen recently. To a man, they had all looked starved for sleep and food, bright-eyed with excitement, neglectful of family and employment . . . quite ignorant and indifferent as to whether it was Tuesday or August, but able to tell you within a kilocycle and a split second just when Zeesen next "opened up" or why that British Empire transmitter on 11865 kc. came in so clearly before noon. You shuddered a bit, knowing that such things could be carried too far . . . but of course it would never happen that way in your case—so you thought!

Followed the feverish activity of assembling the receiver and making various and widely differing stabs at the mystery of wiring same. Just which post on the variable condenser was the rotor, and why weren't the silly parts marked? And was there a head and tail to those flat fixed condensers?

As for winding the coils—did white

men really accomplish such feats as a hobby, and survive? No wonder they had that wild and startled gleam in their eyes! Solder, perhaps?

You had to insulate a rheostat and that 50,000 ohm variable resistor from a metal panel, but not condensers, at least not the variable ones. A bakelite panel gave insulation, but no shielding. And you absolutely refused to believe the author had ever piled, let alone wired, all those parts on a measly 9" x 11" base.

Despite all your fears to the contrary, your Great Moment arrived at last. The (Continued on page 447)

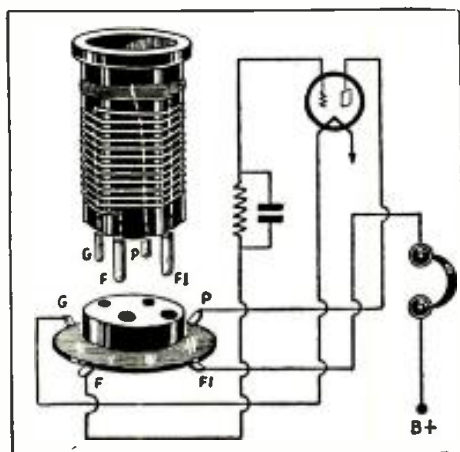

Proper grid and tickler coil connections.

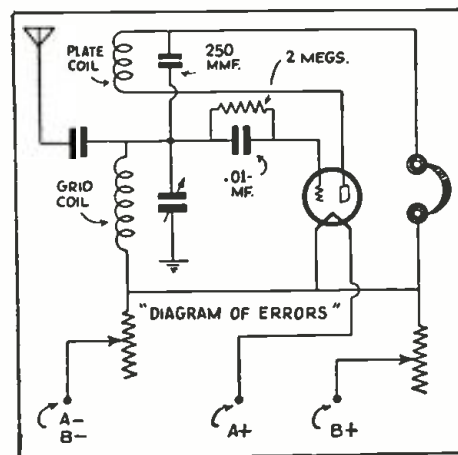

Diagram showing the usual mistakes made by the beginner.



# OUR COVER — XGW—SHANGHAI Calling?

• OUR cover painting this month shows what we would term the sublime height of practical joking. Just imagine if you were listening in, on a newly built receiver and the first station you tuned in happened to be XGW, Shanghai, China! This undoubtedly would create a feeling of superiority in set building. However, we dread to think what might happen when you

The cover illustration shows that moment of great jubilation when the short-wave listener believes he has picked up Shanghai, China, thousands of miles away! But, wait until he learns that a brother "fan" next door has played a trick on him. The article tells how.

If some of our friends are interested in *wired wireless* they can construct something along these lines and communicate over the telephone or electric wires with their friends next door. In using a system like this, it must be stressed that care should be taken *not* to radiate a signal "over the air", which may inter-

(Continued on page 438)

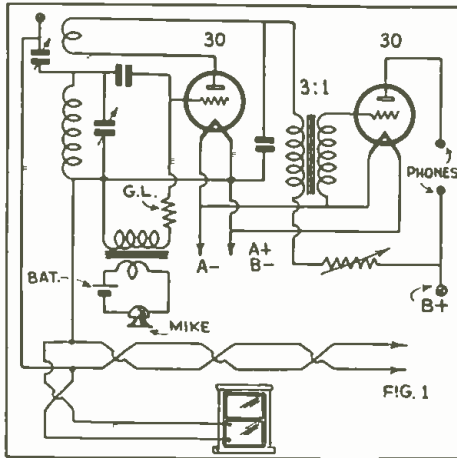
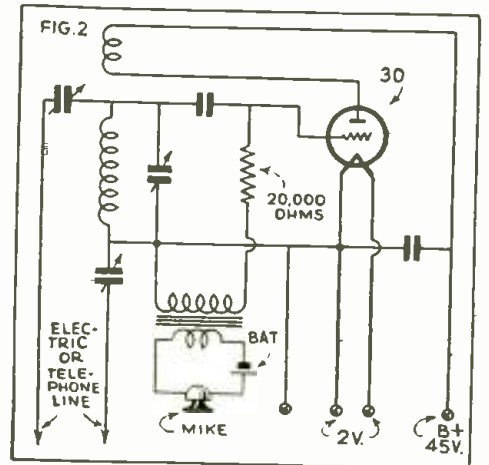

Fig. 1 shows diagram illustrating how the "Chinese" boy fooled his friends.

discover that your playful "Chinese" neighbor had pulled a fast one on you. You may say "Darn clever, these Chinese," and then again you may say something that we would not care to print—Hi! As long as we have gone this far, it might be well to go further and tell you how this practical joke was actually "engineered".

In Fig. 1, we have a plain 2-tube receiver using a regenerative detector and one stage of audio. By connecting the microphone transformer in series with the grid leak and connecting the antenna and ground posts of the detector to the transposed lead-in, we have a form of "wired wireless". The detector, of course, will have to be oscillating in order to transmit the signal over the wire to the receiver below.

In Fig. 2, we have essentially the same circuit, minus the audio amplifier.



With this circuit "wired-wireless" transmission can be performed.

## What British Are Doing With 5 Meters

• CONTRARY to popular belief, our foreign brothers are experimenting with the ultra high frequencies with as much interest as we are here in the United States. The two very interesting photographs shown below will give a fair idea just to what length some of the British amateurs have gone in order to make fairly accurate observations of the behaviour of the ultra high frequency signals. H. L. O'Heffernan (G5BY) has constructed a most elaborate mobile installation. The large box mounted on the rear of the automobile contains both the transmitter and receiver and operates on 56 megacycles (5 meter band). The transmitter is located on one side of the box and the receiver on the other. Two separate antennas are shown, one on each side of the case. For directive measure-

ments in receiving, the transmitting antenna is used as a reflector. When transmitting the receiving antenna can be used as the reflector. This is a very unique arrangement. However, directive transmission and reception cannot be obtained in one direction unless the car is turned around. The antennas are constructed of heavy nickel-plated metal tubes. These tubes can be dismantled by just unscrewing the nuts on the insulators. The rear of the case, as can be seen from the photograph, has a hinged back plate which, when lowered, completely encloses the ultra high frequency apparatus. We believe it would be well for some of our American amateurs to construct a system of this type. Of course, a great number of American amateurs have already installed mobile *transceivers*. However, we have never heard of any being as elaborate as Mr. O'Heffernan's. Mobile transmitters and receivers are really ideal for making ultra high frequency observations because it more or less eliminates the errors which may enter into the tests of point-to-point communication where the condition between the two stations may be either excellent or very poor. With the mobile apparatus, tests can be made under varying geographical

(Continued on page 447)

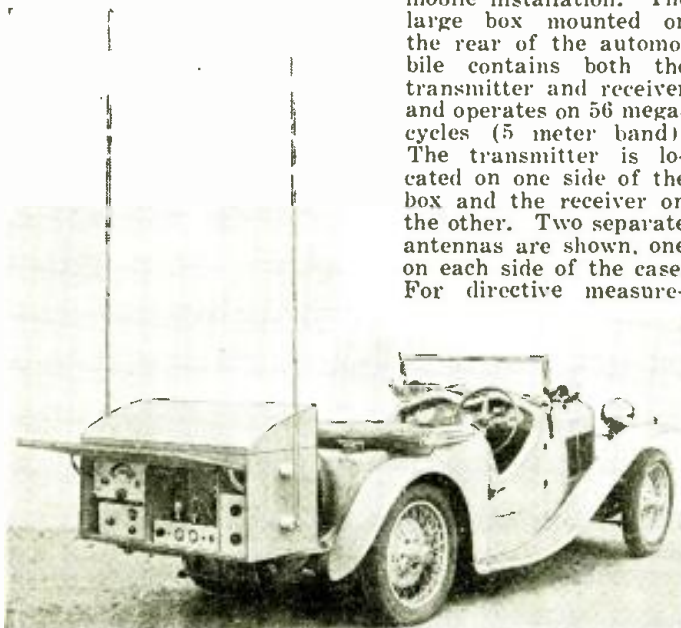

Above—General view of the 5-meter transmitter and receiver built in a substantial weather-proof cabinet on the rear of an English amateur's car; right—close-up of the 5 meter "rig."

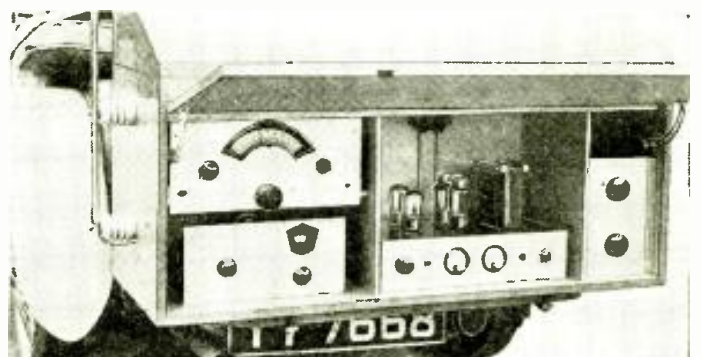



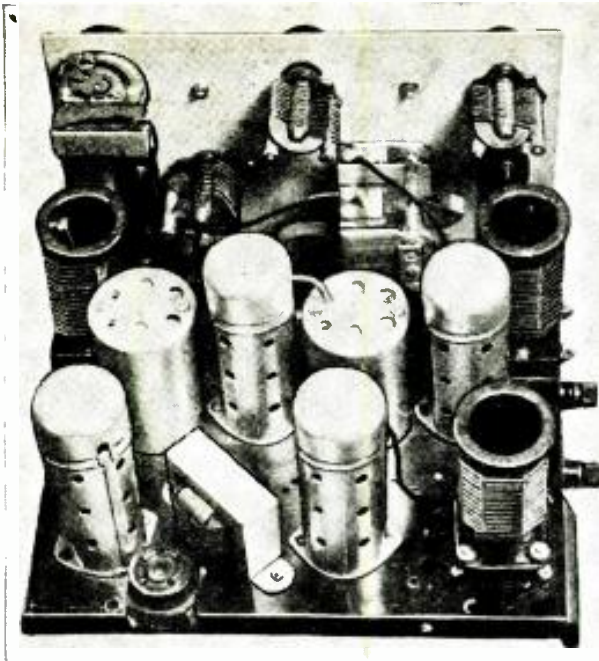

Rear view of the Improved Victor 2-Tube Superhet with added R.F. and A.F. stages, as described in detail by Mr. Woehr.

# Improving the VICTOR 2 Tube Super-het

By W. A. WOHR, W9PTZ

Hundreds of readers of this magazine have built Mr. Victor's 2-tube superhet and have reported surprisingly fine results obtained with it. The present author describes how to add a stage of tuned R.F. and also an A.F. stage to the original Victor circuit. With these improvements extremely good loud-speaker reception can be enjoyed.

● **RESULTS** obtained by those who built the Victor 2-Tube Super-Het, described in the December, 1933, SHORT WAVE CRAFT, testify to its high efficiency in "pulling 'em in," despite the fact that only 2 tubes and a minimum number of parts are used. At the author's location, generally considered as being only "fair," this little set brought in all the well-known foreign short wave stations as well as a host of U. S. amateur, police, commercial and experimental stations. Consistent results of the "Victor" were certainly *above par* as compared with the usual run of popular short-wave receivers tried out, including both home-made and factory-built sets.

However, it was felt that this two-tube super-het would serve admirably as the basis for something just a little better, and capable of much greater performance, both as a stationary and as a "portable" receiver, with only a few changes and the addition of but two tubes.

### R.F. and A.F. Stages Added

The main improvements, as first noticed on viewing the set (from the front), are a pre-selector stage of tuned R.F. and one stage of audio amplification. The other tuning dial is for *band-spreading*. The original oscillator circuit, using the triode portion of the 6A7, has the tickler of the oscillator coil, connected in the plate circuit. With a very steady line voltage or using "B" batteries, the original hook-

up holds the weaker signals very steady but any variation of  
(Continued on page 431)

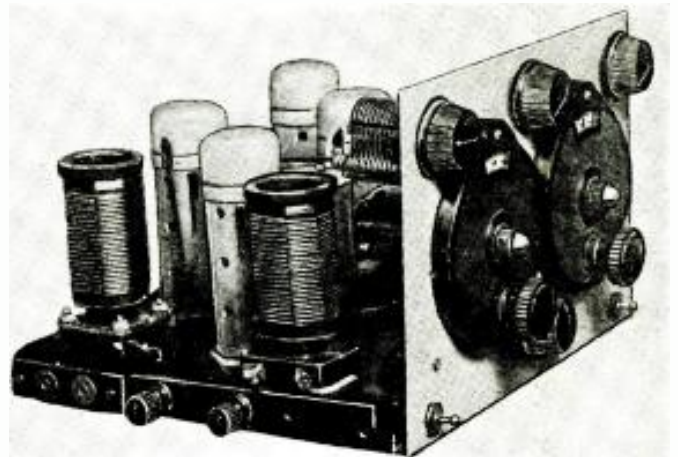

Perspective view of the Improved Victor superhet with added stages of R.F. and A.F.

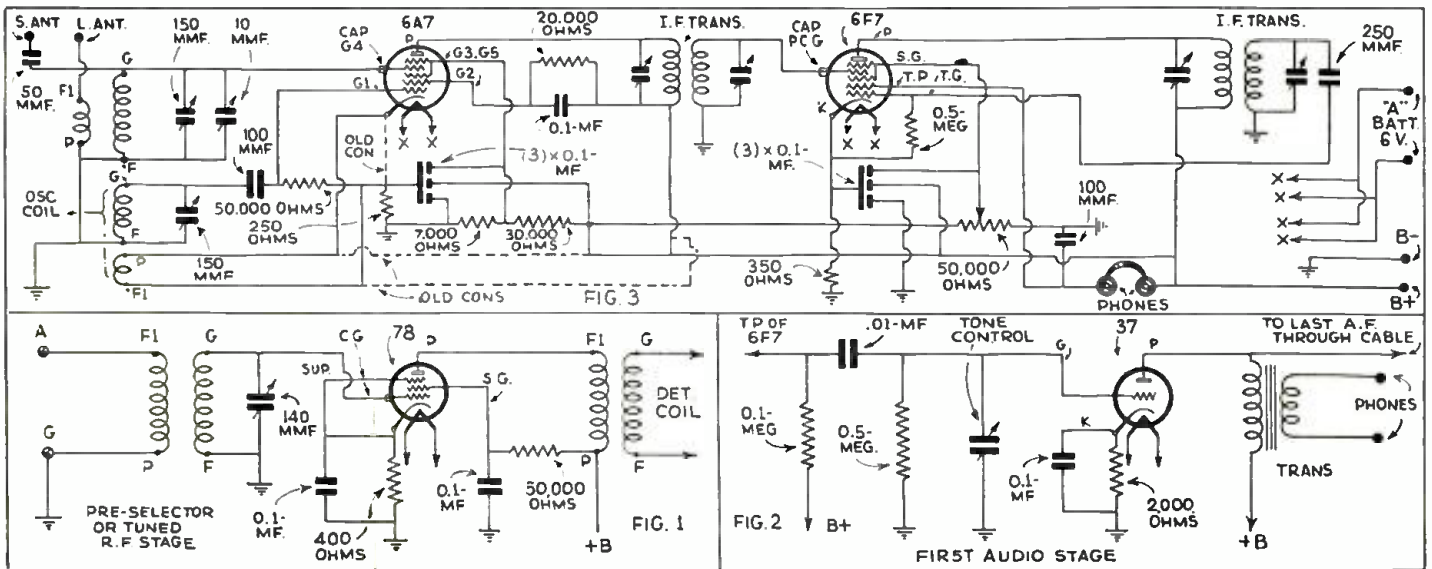

Wiring diagram of the original 2-tube superhet as described by Mr. Victor and also the additional radio and audio frequency stage diagrams, to be added as described by Mr. Woehr.



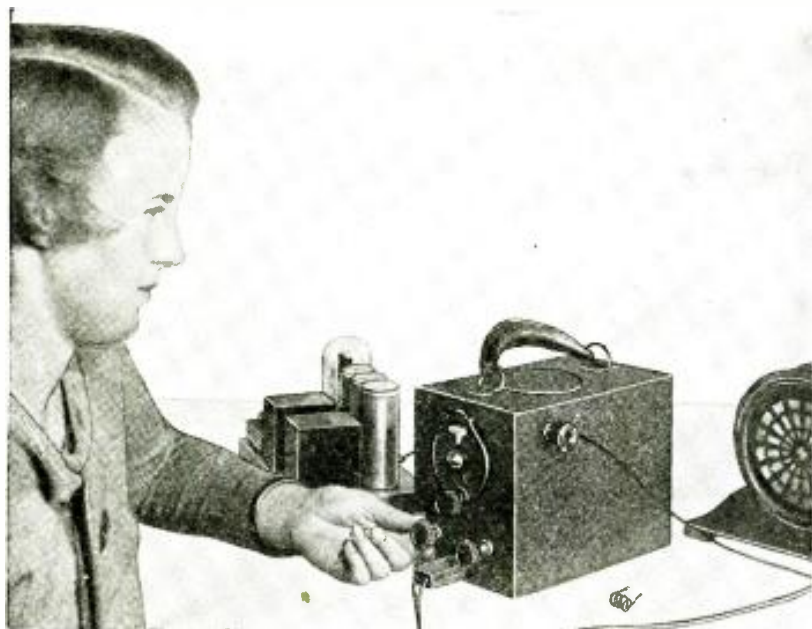

Above we see the new 2 to 5 meter receiver which will also serve as an excellent "portable" receiver.

● NEVER before in the history of amateur radio, has the amateur had so great an opportunity of showing his skill in designing new equipment to be used in an entirely new field of short-wave radio. The recent ruling by the Federal Communications Commission permitting the amateur to use the entire high frequency spectrum above 110 megacycles, provides the amateur and experimenter with opportunities equal to, if not indeed, exceeding those of the days when 200 meters represented "short waves". The amateur so ably developed equipment to make use of those *short waves* (that no one wanted then), that it is a very safe bet to say that it will only be a very short time until the "ham" has done the same thing with the now more or less useless *ultra high frequency* spectrum, as most people have called it, and once more established himself as an important part of the greatest group of radio experimenters in the world.

Not so long ago the writer heard some one say—"the romance has practically gone out of radio". But today it is a sure thing that for those who like to DO THINGS there is romance and fascination in the ultra high frequencies heretofore undreamed of. The writer has spent the best part of the past three years delving into the possibilities of the ultra high frequencies. Many extremely interesting things were uncovered and proved to be contrary to popular belief.

The ultra-high frequency transmitting and receiving "gear" of tomorrow will look as different from the present-day apparatus as the old "spark-coil" outfit looks compared to the modern vacuum tube sets; witness the writer's 5-meter transmitter described in the last issue of this magazine and the 2.5-meter outfit described elsewhere in this issue—and these are by no means the ultimate. Receivers will also take on the improvements set forth in these transmitters. We could go on for hours talking about these things but the purpose of this article is to describe a "new" receiver. All we can say is—*get busy on the ultra high frequencies and experience once more the real thrill of the "old days"*.

**A New Ultra-Short Wave Receiver**

The receiver shown in the photographs was designed with two important things in mind. First, a receiver with improved sensitivity and second, one that could be used on wavelengths down to 2 meters. It was also borne in mind that the experimenter must have a receiver of the best possible design, at the present time, to form a basis for further experimentation; for nothing can be done in that direction without a standard to go by. This receiver has accomplished all of the outlined objectives and is far more sensitive to *weak signals* than any *present day super-regenerator*, regardless of the type of tubes used. The back-ground noise, or hiss, is very low in this set, a further aid to weak signals, and besides it is very simple and economical to build.

In experimental work it is preferable that the receiver be sturdily constructed, and designed for *portable* use. It is for this reason that the set was built in a metal carrying case; it can therefore be readily used in an automobile or boat when carrying on experimental communications. Anyone desiring a better high frequency receiver for the

# 2-5 Meter

George W. Shuart, W2AMN

Here is one of the most efficient ultra-high frequency receivers we have had the privilege of describing. It uses only two tubes, a 56 super-regenerative detector and a 2A5 pentode amplifier for A.C. operation. It can be used in an automobile or boat, by the use of a 6 volt auto "B" eliminator in which case the detector will be a 76 and a 41 for the audio amplifier. This set is surprisingly sensitive and selective.

home station, will find this set "just the thing".

**Circuit Very Simple**

Referring to the circuit diagram we find that the set is *simplicity* in itself. Only two tubes are used and provide *full loudspeaker volume*, far too much for the largest of rooms! A triode is used as the super-regenerative detector, in a circuit which lends itself beautifully to our requirements. A pentode is used as the audio amplifier with a volume control placed in its grid circuit, in order that earphones may be used. The entire set is enclosed in a black crackle-finished carrying case, measuring but 5 1/4 inches wide, 6 3/4 inches high and 8 3/4 inches deep. The case is in two sections, clearly indicated in the pictures, and is equipped with a convenient handle for carrying purposes.

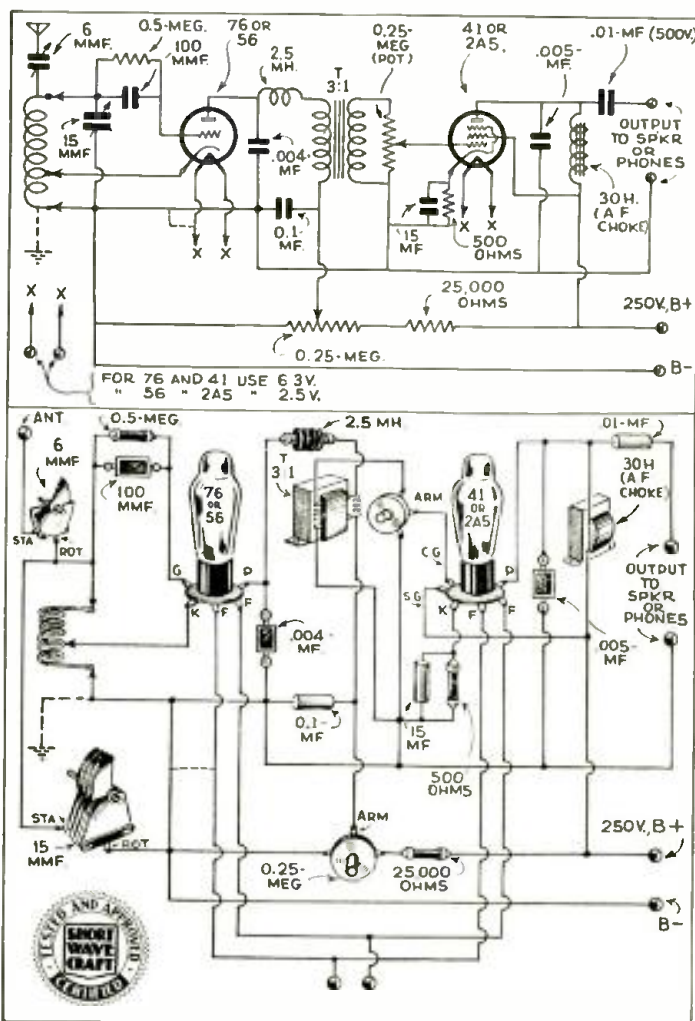

The schematic and physical diagrams shown above clearly show how to wire the 2 to 5 meter receiver.



# Set Works Speaker



The *tuning* is done with the small National dial on the front, while *regeneration* is controlled by the knob in the lower left-hand corner. The *audio volume control* is located to the right. The speaker or phone jack is located between the two last mentioned controls.

The small knob on the left-hand side of the box is the *antenna coupling condenser*, along side of this condenser is the antenna binding post; the power cable is brought out the back. Inside the can is mounted a 6½ by 4½ by 1/16 inch aluminum shelf on which most of the parts are mounted.

## Tuning and Super-Regeneration Features

The tuning circuit consists of a single coil and a condenser making it much easier to change coils. The grid is connected to one end of the coil, through the grid-leak and condenser, and the "B" negative is connected to the other side of the coil. Regeneration is obtained by connecting the cathode of the tube to a point near the center of the coil, making it above-ground R.F. potential. When this is done the plate must be brought as near ground R.F. potential as possible. This is accomplished by the .004 mf. by-pass condenser connected from the plate to the "B" minus. The leads of this condenser must be very short and the "B" minus lead of the condenser should connect to the same point on the chassis as the ground end of the grid coil. In this circuit the rotor of the tuning condenser is at *ground potential* and eliminates the usual *hand-capacity* or the use of a long insulating extension shaft. *Super-regeneration* is obtained by using quite high plate voltage on the detector and allowing it to break over into *irregular oscillation*, the frequency of which is more or less determined by the value of the grid-leak.

The optimum value of grid-leak was found to be ½ megohm and the grid condenser .0001 mf. The detector tube socket is mounted on top of the chassis to permit *short leads*. The amount of regeneration is very nicely controlled by the 250,000 ohm potentiometer, which varies the plate voltage. The potentiometer is by-passed with a .1 mf. condenser to make its operation smooth and quiet. A 2.5 mh. R.F. choke proved sufficient to keep the low frequency voltage, generated by the detector, from the grid of the audio tube. In this circuit it was not found necessary to connect one side of the heater circuit to the chassis; however, in other cases the builder may find it beneficial and this connection should be tried for best results.

## The Audio Amplifier

The audio circuit is very simple and needs little discussion. A 3 to 1 ratio audio transformer is used as the coupling medium and a 250,000 ohm potentiometer is connected across its secondary for a *volume control*. The *output* is obtained through a choke and condenser arrangement, so that the D.C. plate current does not run through the speaker or phones, whichever is used.

The 5 meter coil has 7 turns of No. 12 tinned buss bar with ½ inch inside coil diameter; the spacing between turns is 1/16 inch. The cathode tap is on the third turn from the

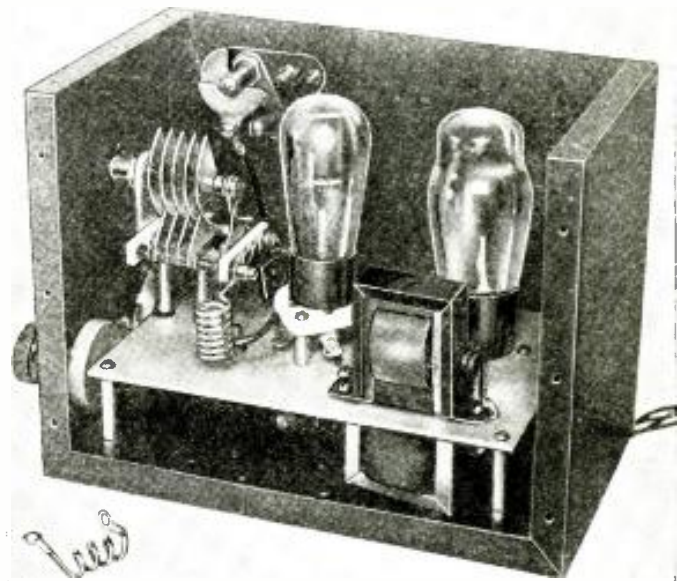

Here we have the inside view of the set, showing just how the parts are placed.

*ground end*. For 2.5 meters the coil has 4 turns, ¼ inch inside diameter and 3/16 inch spacing between each turn. The tap is at the center of the coil.

All in all, this set is far more sensitive than the average and is about three times as selective. It ran rings around all other 2 to 5 meter sets compared with it. It is simple to build and costs very little, and can be run on batteries or a power-supply.

The writer has found some very interesting effects regarding the position of the receiving antennas for both 5 and 2½ meters. If a vertical half-wave rod is used and the lead-in taken off from the top, the signal strength will be found to be from 100 to 200 per cent greater. This can easily be proven by setting a vertical half wave rod along side the receiver and sliding the lead-in from top to bottom. The best point as mentioned before will be at the top of the vertical rod. If the antenna is mounted vertically on top of a building the lead-in should also be taken from the top and *not* the bottom. Recent tests have proven that signals could be received "R8" with the connection taken from the top; with the connection taken from the bottom these signals were absolutely inaudible. We hope to have more information along the lines of ultra high frequency antennas at a later date.

(Continued on page 427)

## Eliminating "Fringe Howl"

● IN SPITE of the many improvements in short-wave sets during the last few years, "fringe howl" or "threshold oscillation" is still with us, especially in home-made sets. The most common method of getting rid of this trouble is to shunt a ¼ megohm fixed resistor across the secondary of the first audio transformer. Unfortunately this method, while eliminating the howl, eliminates most of the signal also.

The radio-frequency filter circuit is the writer's favorite method of eliminating the troublesome howl. The arrangement shown in Fig. 1, consists of two 2½ millihenry R.F. chokes connected to three fixed condensers as shown. The circuit is exactly the same as that used in power supply filter systems, except that radio frequency chokes and small capacity condensers are used.

Sometimes very good results can be obtained by the use of only one choke and

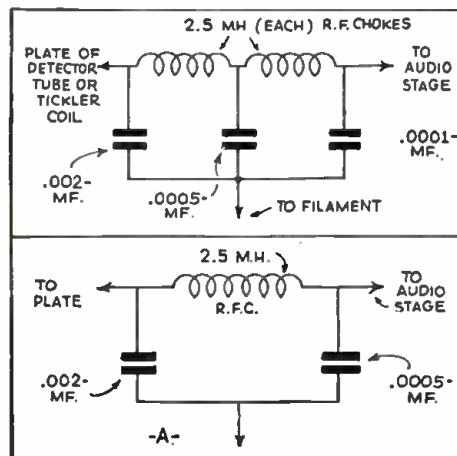

Two methods described by the author for eliminating "fringe howl."

two condensers as shown in Fig. 1 "A". In either case use only chokes which are wound on isolantite forms and are treated with some kind of moisture repellent.

In many cases where pentode amplifiers are used in regenerative receivers trouble is experienced when the detector is near the oscillating point due to feedback between the audio stage and detector. This is in the form of a high pitched howl and can be very easily overcome by connecting a small by-pass condenser between the plate of the pentode tube and the B negative side of the circuit. The size of this condenser depends entirely upon the amount of feedback present. Usually any size from .002 mf. to .006 will cure the trouble. The pentode amplifiers also have the characteristic of giving a very "thin"

(Continued on page 441)



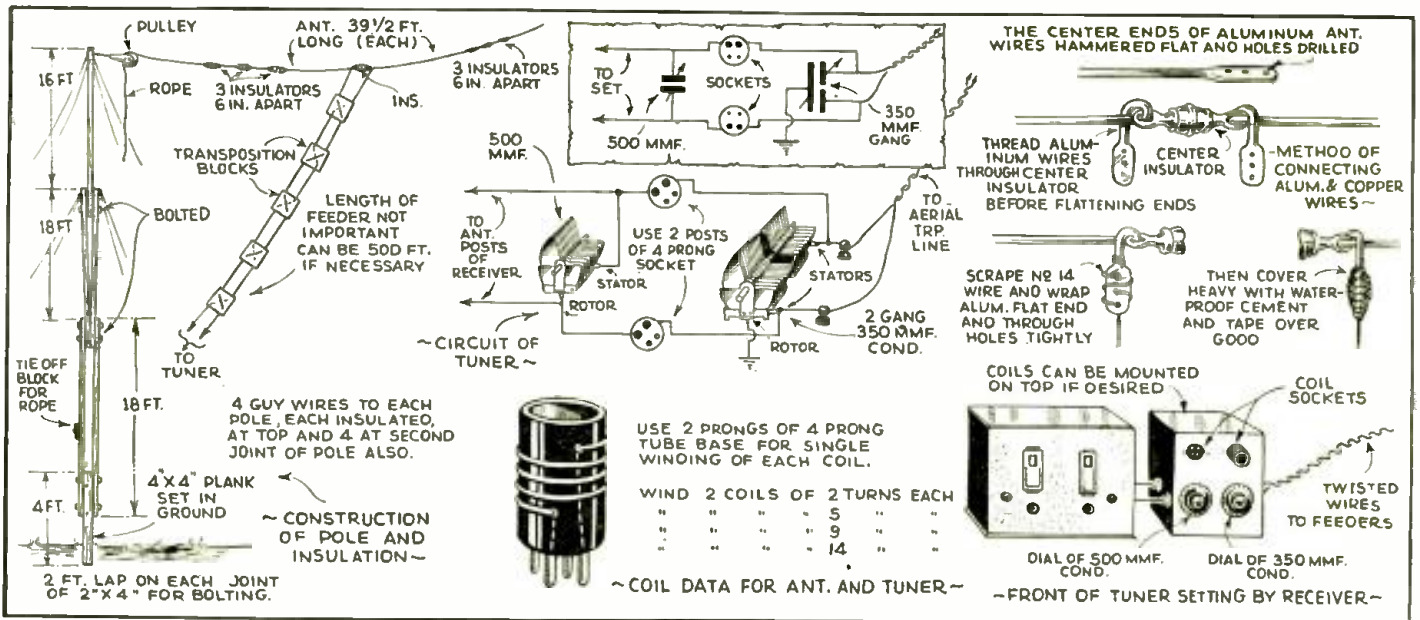

Details of the special directive doublet antenna used by Mr. Johnson to "listen in" to European S-W stations are given above.

# Best Aerial for "Europeans"

• BECAUSE Europe with the D-G and F signals affords a goodly portion of the pleasurable listening, we have built a special antenna for reception of signals from that continent.

The top, or antenna proper, consists of two 39 1/2 foot lengths of No. 4 aluminum wire at a height of 47 feet above ground, swinging from rope tie-offs between two wooden poles, made from 2 by 4's per sketch. The lead-ins are of No. 14 enameled copper wire, transposed each 15 inches, on home-made insulation blocks which were cut from plywood and boiled in paraffine.

Since aluminum cannot be easily soldered, except with special solder, the ends were flattened out with a hammer as shown and the copper lead-ins, after being well scraped, were wound in and around the holes in the flattened ends of the antenna conductors. Afterward the connection was covered with waterproof cement and well taped over. This forms an excellent connection we have found.

**By HEINIE JOHNSON**  
First "Trophy Cup" Winner, Short-Wave Scout Contest

The lead-ins are brought through the wall to a special antenna tuner by means of twisted lamp cord. This tuner consists of one two-gang .00035 mf. condenser block, two coil sockets, one .0005 mf. condenser and four sets of coils (two to the set) wound on tube bases—and arranged as shown in the diagram. Coil data is described separately. The lead-ins are taken from this tuner to the antenna posts of the first T.R.F. stage. The antenna coil of this first stage has been freed of ground connection and brought back to the second antenna post, in order to complete the antenna circuit as a whole and the two .00035 mf. condensers furnish the ground capacity used in the antenna circuit—usually you'll find best operating conditions with these condensers well open; i.e., rotor plates well out of the stator plates.

The efficiency of this hook-up will surprise you. You will find it possible to "peak" a signal to the extent of having FYA's 25.63 meter signal come in strong enough to "shake" a heavy loudspeaker with vibrations of their carrier alone, when no program is on! This will also prove true of the GSD and GSF carriers during the usual short periods when the carrier is on, but no transmission is sent out. Of course, such antenna efficiency will bring in the program much better than the aperiodic form afforded by a transformer coupling, but will also require considerably more tuning than is required with the usual coupler. We don't mind that and don't believe any "dyed-in-the-wool" short-wave fan will either.

This antenna is "plenty" efficient from 6,000 kc. to 25,000 kc.; therefore covering the best part of the DX bands. It would work equally well if placed so as to be directional to South America, but since we built it for European and

(Continued on page 430)

# How To Tune In Short-Waves On Broadcast Set

• HERE is an idea that may be applied to any broadcast receiver of the superhet type. The idea is simple enough and that is to lower the inductance of the antenna secondary so that the accepted frequency will mix with the second harmonic of the regular oscillator, producing the desired intermediate frequency.

Take the Philco Model 80 for an example: We have just one tuning circuit between the antenna and the first detector oscillator tube, so in order to get the 160 meter phone band we connect a small coil across the antenna secondary in a shunt arrangement. This may be done without pulling the chassis from the cabinet by winding about thirty-five turns of No. 28 enameled wire on a coil form, about one and one-half inch or two inches in diameter, grounding one end

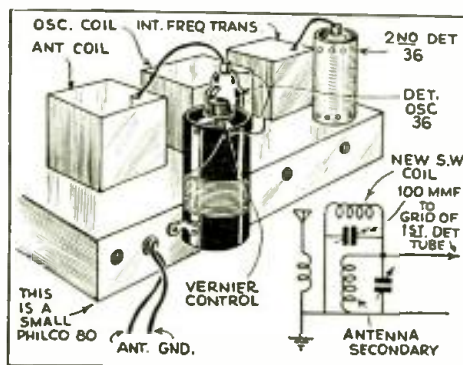

By connecting a small coil across the first detector grid coil, as explained, short waves can be tuned in on a B.C. receiver.

of the coil to the chassis and connecting the other end to the top cap of the detector-oscillator tube. The inductance may be varied to match the oscillator by varying the space between the turns of the coil nearest the grid end. The top cap connection should be made along with the regular connection to that tube.

The second harmonic of the oscillator will change about twice as fast as the fundamental accepted through the shunt arrangement, so that full efficiency will only be possible over a short part of the dial. To get away from that bad feature we mount a small variable midget condenser on one end of the coil form and connect it across the coil winding. This makes it possible to adjust the shunt coil's inductance, so as to obtain full efficiency over the whole dial scale.

—J. F. ROESE.



# More Power on 2.5 Meters With Triodes

By GEORGE W. SHUART, W2AMN

We are pleased to present this very efficient 2.5 meter transmitter, in which present day tubes can be used with considerably more output than can be obtained with the ordinary "coil-condenser" combination. In this circuit, the tube elements actually form a part of a half-wave "resonant transmission line." One-quarter inch copper tubes are used and fit directly onto the plate and grid terminals of the tube, in order to eliminate losses in long connections. This transmitter can also be operated as low as one and one-quarter meters with a surprising "output" and a marked increase in "stability" over the usual ultra-high-frequency transmitter.

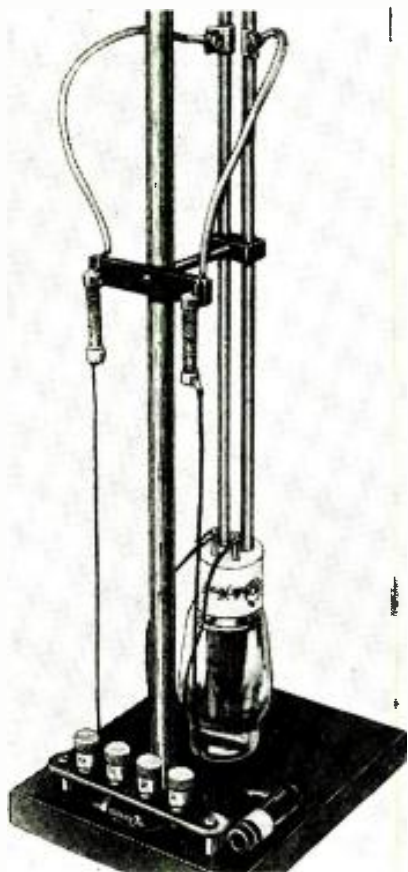

Left: Close up of 2.5 meter transmitter using resonant transmission line.



Right: The 2.5 meter transmitter, together with the voltage curve along the transmission line.

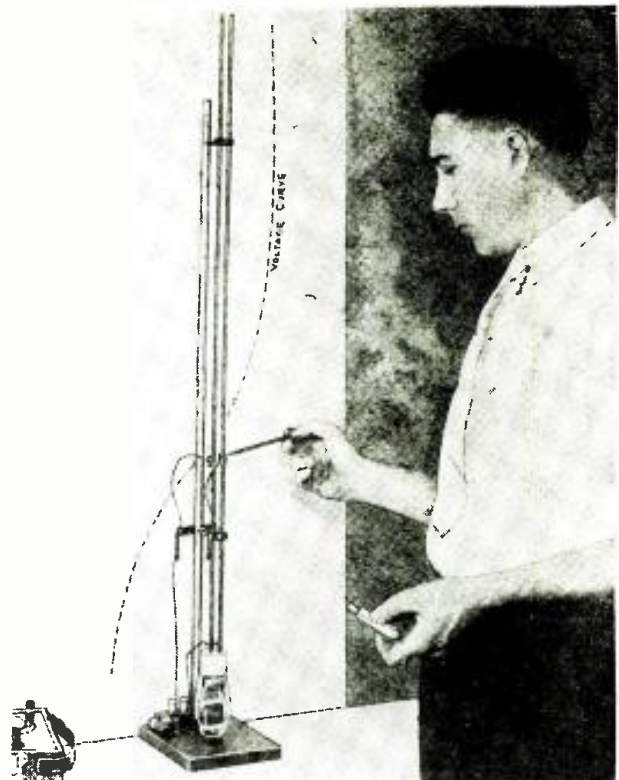

municate over any appreciable distance at all. This transmitter together with the receiver described elsewhere in this issue, has proved to be "workable" over distances up to 14 miles, with an R9 signal under ordinary geographical conditions. No one knows, as yet, the maximum possibilities of these frequencies and no doubt it will be quite some time before they do.

However, from the author's experience with these ultra-high frequencies it can be safely said that they exhibit essentially the same characteristics as does the five meter signals. It has been found that the transmitting and receiving antennas need to be a considerable height above the ground and that they are very directional: that is the directional qualities of these antennas are more noticeable than those operated on lower frequencies. The receiving antenna especially is very critical. The horizontal receiving antenna with its directional effects, seems to be superior to the vertical affair in most cases. The vertical transmitting antenna, of course, was used and is recommended as it radiates fairly well in all directions.

### Details of Oscillator

The transmitter shown in the photo probably looks like anything else but what it is. As we have said before though, no one knows what our ultra high frequency apparatus is going to look like

in the future, so don't let its appearance affect you too seriously. The transmitter uses a single tube employed as a feedback oscillator, not a B.K. oscillator. Barkhausen-Kurz oscillators are notorious for their *low output*, even with special tubes. This oscillator uses an *open-end* transmission line, while last month's transmitter used *shorted-end* lines. *Shorted* lines would be far too short on 2.5 meters to derive any benefit from them. Push-pull was not used in the transmitter as considerable difficulty is encountered when *open-end* lines are used with tubes in push-pull. Further experimentation will probably result in the use of a tube at each end of the line. However, for the present this trans-

(Continued on page 426)

SEVERAL of our friends have constructed the new 5 meter transmitter described in last month's SHORT WAVE CRAFT. They all experienced quite a surprise when they found out how efficient and stable the "rig" was. The output was reported to be three or four times as much as obtained with a conventional oscillator. And the writer was asked if the same principle could be applied to a 2.5 meter oscillator for use in the newly allotted amateur frequencies. It surely can, and such a transmitter is described in this article.

There is little use of going on the wavelengths below 2.7 meters with the regular parallel tuned oscillator as the R.F. output is extremely low, even with large inputs, the plate efficiency being so low as to practically ruin a tube in short order. Then again, being more or less unfamiliar with the characteristics of the extremely high frequencies, we need an oscillator that has a fair amount of output in order to enable us to com-

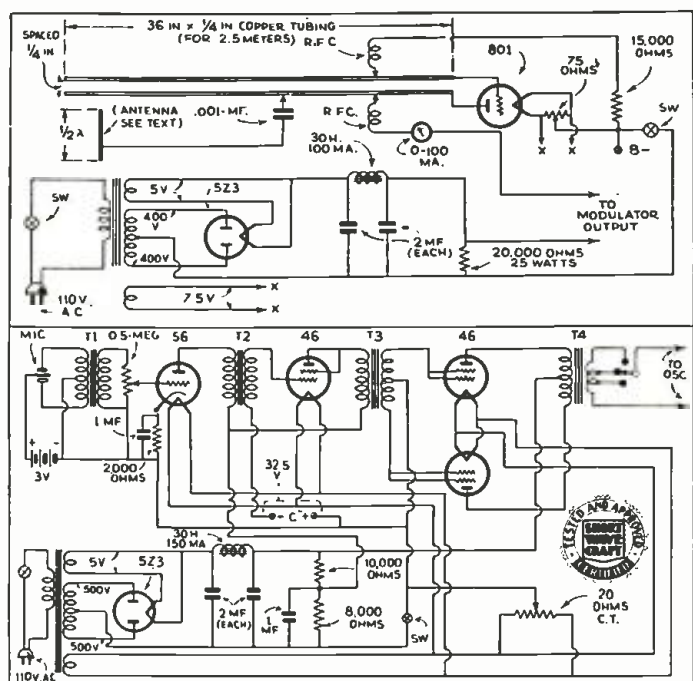

The diagram clearly shows the connections of the new transmitter, together with a recommended power supply and a modulator.



# WORLD-WIDE SHORT-

## A 10 Watt Phone Transmitter

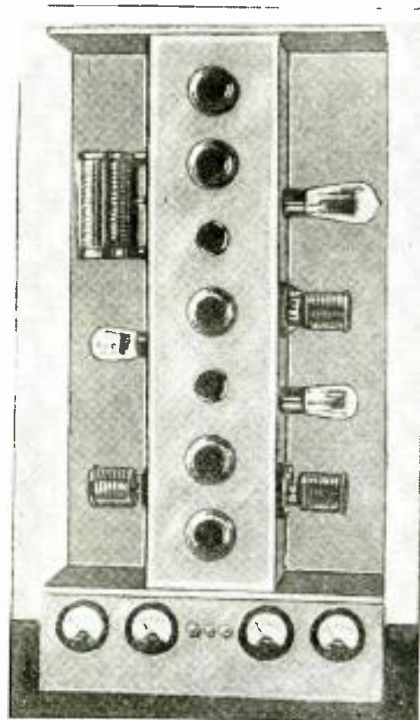

Above we have the very unique 10-watt phone transmitter. The chassis design is such that a minimum of interlocking between the various stages is obtained.

● IN THE T. & R. BULLETIN, the official organ of the Radio Society of Great Britain, recently photographs and a description of an amateur transmitter of unusual design were printed. This transmitter, instead of being mounted on the usual breadboard or panel and shelf, is scientifically laid out to provide not only the shortest possible leads and most efficient shielding for the various circuits but also the most convenient arrangement for circuit changes and adjustments.

The circuit is also scientifically designed and appears on this page for those who might be interested in analyzing it. A glance at the circuit shows that it is a crystal controlled master-oscillator arrangement with provision for using the second harmonic of

● The editors have endeavored to review the more important foreign magazines covering short-wave developments, for the benefit of the thousands of readers of this magazine who do not have the opportunity of seeing these magazines first-hand. The circuits shown are for the most part self-explanatory to the radio student, and wherever possible the constants or values of various condensers, coils, etc., are given. Please do not write to us asking for further data, picture-diagrams or lists of parts for these foreign circuits, as we do not have any further specific information other than that given. If the reader will remember that wherever a tuned circuit is shown, for instance, he may use any short wave coil and the appropriate corresponding tuning condenser, data for which are given dozens of times in each issue of this magazine, he will have no difficulty in reconstructing these foreign circuits to try them out.

the master-oscillator frequency for frequency doubling purposes. For use on the fundamental frequency of the master-oscillator, one of the tuned circuits in the plate lead of this tube is short circuited. Following the master-oscillator are two power amplifier stages, the second of which is modulated by a separate modulator and keying tube.

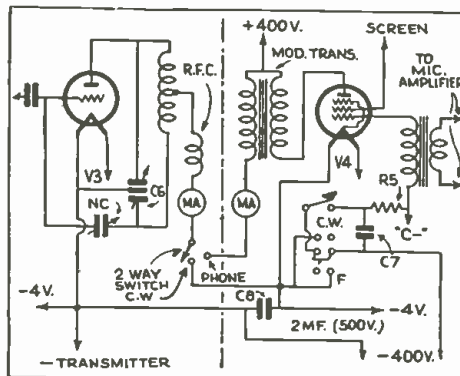

Above—We see the diagram of the simple modulator for the 10-watt phone transmitter.

The keying circuit is rather novel, since it employs a tube instead of cutting off oscillation by any of the usual methods. The tube which acts as a modulator for phone work is biased well beyond the cutoff point and is arranged in series with the plate supply to the tube which it controls. Shorting out the bias resistor with the key breaks no current but allows the controlled tube to receive plate current. As the key is lifted the bias naturally cuts off all the conductivity and the wave is thus effectively keyed. This eliminates the tendency towards loud key clicks which are so prevalent in some amateur signals.

A glance at the panel arrangement of the transmitter, which is designed for operation on 1.7 and 3.5 megacycles will show the handy arrangement of parts. It will be noted that the radio frequency coils are well separated and shielded in completely enclosed compartments. Two of the shields are removed in the photograph to show the position of these coils. The novel method of mounting the parts provides six surfaces for the radio frequency components in place of the usual single surface in the breadboard design.

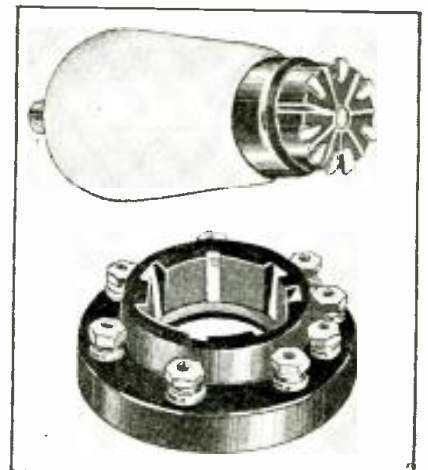

New tube base and socket design providing positive contact at all times.

### "Pin-Less" Tubes

● RECENTLY, several large European tube manufacturers have placed on the market tubes using *side contacts* instead of the usual contact pins. One of these tubes is shown in the accompanying illustration, which was printed in *Wireless Magazine*. It will be noticed that this tube has 8 contacts and even with this number the circumference of the base is not crowded. This shows the superiority of this method of construction for multi-element tubes such as those recently introduced on both the European and American markets. Incidentally, the tube shown is a pentagrid converter, similar in design to the American 2A7, except for the addition of a suppressor grid, thus making the first detector an R.F. pentode of the variable mu type.

The appearance of one of the tube sockets for this "octode" is shown here. It will be noticed that this method of constructing sockets is also an improvement over the old method of having spring clips which grip the tube prongs. The clips are inclined to spread after a time thus making poor contact, while the contacts in this new type of socket are backed up by the solid wall of the socket.

We believe that in time, American tube manufacturers will find it of interest to follow a similar style in the construction of multi-element tubes.

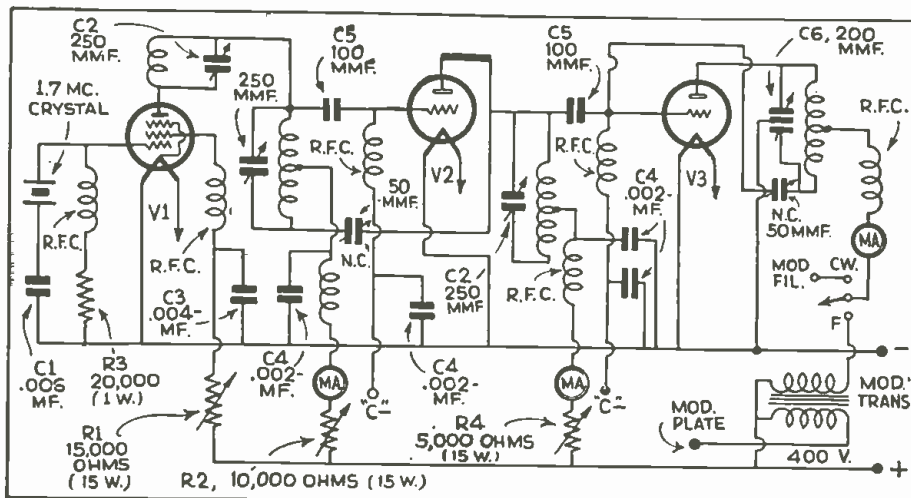

Diagram of the 10-watt crystal-controlled transmitter, where doubling is done directly in the plate circuit of the oscillator tube.



# WAVE REVIEW

Edited by  
**C. W. PALMER**

## The Picard Aerial for 5 Meters

● IN A recent issue of that interesting booklet—*The T & R Bulletin* of the Radio Society of Great Britain, the description of an aerial used by amateur station 2AVN was published. This description contained many useful facts for the amateur who is working on the 56 megacycle (5-meter) band.

The Picard aerial at this station is a half-wave unit, fed at the center by means of three spiral coils of a few turns each, placed side by side and connected together to form an auto-transformer. The feeders are connected to the outer ends of the coils (X) while the taps to the aerial are taken off at points Y in the accompanying circuit. This method of matched impedance has been thoroughly tested by 2AVN, and the results definitely proved that it is superior to any other form of aerial coupling. The great advantage is that any convenient length of feeder lines can be used; wires from 4 to 45 feet have been tried with identical results.

The actual aeriels used are telescopic legs from a camera tripod, with the impedance matching coils mounted in the center. It has been found that the rods have to be pushed in to a length of 43 inches instead of 49 inches due to the loading of the coupling coils at the center.

A varied collection of results has been accumulated, but one thing is agreed by all, that superior results are obtained by arranging the aeriels as shown at B in the accompanying circuit. It will be noticed that one-half of the aerial (that is, one 1/4 —wave rod) is vertical. The other can be placed

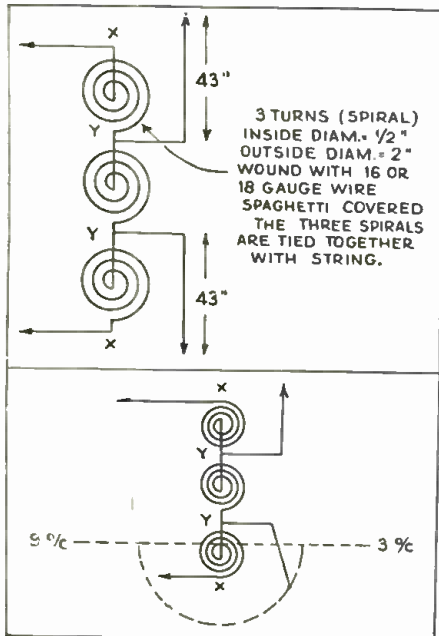

Two diagrams showing different methods of connecting the Picard antenna. Fig. A is the upper drawing and Fig. B is the lower.

in any position over the arc shown in the sketch.

The description in *The T & R Bulletin* offers no explanation for the latter phenomenon but it is suggested that it is due to the fact that the polarization of the signals change and this happens to suit the aerial arrangement at the receiving end, or vice versa, when the Picard aerial is used for reception purposes. This seems to offer a field for experimentation as there appears to be little doubt that the angle of polarization does not remain constant from transmitter to receiver, and in some cases is twisted as much as 90 degrees.

(EDITOR'S NOTE: Tilting one side of the doublet antenna or, the entire antenna, makes quite an improvement on most signals. We have noticed that certain 5 meter signals cannot be received unless the antenna was tilted in a certain direction and at a certain angle. It is well for our many 5 meter enthusiasts to devise a method for tilting their antennas in order that maximum results can be obtained.)

## A New Dial

● IN A recent issue of *Wireless World*, an interesting, new dial was shown. This dial is of particular interest for short-wave receivers since it has an unusually long scale to make easy tuning, and since a paper or celluloid strip is used, stations may be logged directly on the dial.

The construction of the dial can be seen from the illustration. In place of the usual dial and pointer or drum, a flexible paper scale is supported on two rollers at the top and bottom of the dial opening and a third roller supported behind the other two. This paper strip is driven by a series of gears connected to the condenser shaft.

It has the advantage of permitting stations to be recorded in either alphabetical order or in geographic groups, thus greatly facilitating the location of any desired station. Because of the numerous stations crowded in small portions of the short-wave bands, sufficient space is found on this dial to "log" them all.

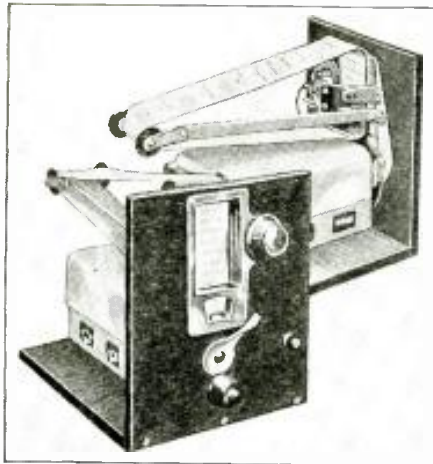

In this dial, the scale is actually of the moving tape type; being very long it should provide easy tuning.

It is interesting to note that a dial of this type can easily be improvised from the drum dial by the addition of the paper strip and third roller, carrying the paper strip over the old drum.

## Short-Wave Antenna Hints

● SOME interesting facts concerning the aeriels used for short-wave reception appeared in recent issues of *Popular Wireless*, an English weekly publication. The first of these is a hint for using a single aerial for both short-wave and broadcast reception. A glance at the illustration shows that a lead-in is brought into the house from each end of the aerial. One of these lead-in wires is connected to the broadcast receiver while the other connects to the short-wave set. When used in this way there is no interaction between the two receivers; each works as though it had an individual aerial and lead-in. The other hint concerns the placement of the ground lead which often introduces noises into a short-wave receiver, if it is placed near an electric light line or is allowed to rub against a wall, gutter or drain pipe. Varying capacity effects or static

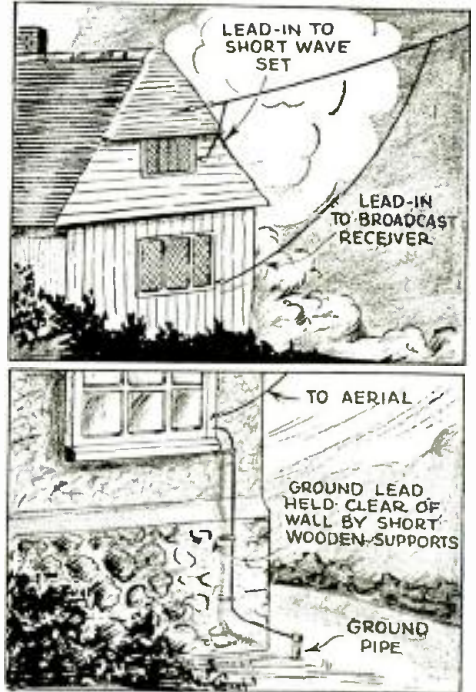

This illustration shows how a single antenna may be used for both "broadcast" and "short-wave" reception.

voltages set up either by induction or friction caused by rubbing introduces static voltages in the aerial coil which are picked up and amplified in the receiver.

The solution to the problem lies in correctly spacing the ground lead from any pipes or wires by the use of wood or other insulated spreaders. A glance at the sketch shows how a typical installation is made.

These simple hints show what interest is displayed in short-wave aeriels in foreign publications. There is no doubt that worthwhile improvements in short-wave receivers can be made by simple changes in the aerial, especially in the position and care with which it is insulated.

## An All-Wave Coil Assembly

● IN *Der Qualitäts Markt*, a German publication, there appeared a short-wave coil unit of unusual design. It consists of four insulated tubes on which the coils are wound with the wave-range switch mounted below. The coils are designed for a superheterodyne type receiver in which the oscillator is directly coupled to the secondary of the aerial coupler. The wave-change switch is a cam type unit with short spring contacts that are compressed by rotating the wave-change knob. This coil unit covers the wave bands between 18 and 200 meters as well as the broadcast band of 200 to 550 meters.

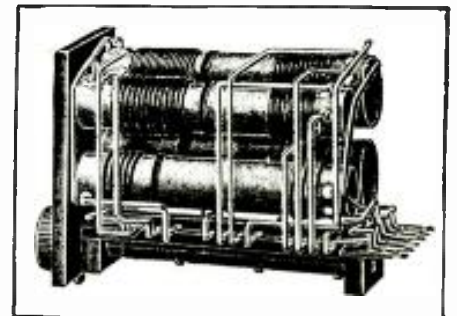

Above we have the illustration of an all-wave coil assembly of German design.

## Short Wave Scout Report From John Sorensen, Bronx, N. Y. C.

● RECEPTION from the G stations, D stations and FYA stations has been very good. CT1AA has been very good; also XEFT on 49.8 meters; PRBA on 31.58 meters; VK3LR on 31.3 meters (mornings); EAQ on 30.4 meters; HJ1ABB on 46.5 meters. Other stations have been heard several times during the month and which are as follows: Aug. 4, 1:30 p.m., Radio Vaticano, also mornings, 5 to 5:15 a.m., E. S. T.; KWU-KWO, Disan, Calif., 19 meters; JVF, Tokyo, 19 meters; ISX, Buenos Aires, 28.98 meters; ORK, Belgium, 29.04 meters; VK2ME-VK3ME; HC2RL, 45 meters; YV2RC, 49 meters, good; YV3RC, 48 meters, good; W1XAZ, 31 meters; also W8XK, 19-25-49 meters; W2XE, 25-49 meters; W8XAL, 49 meters; PH1, 16.8 meters; W3XL, 46.9 meters; W3XAL, 16.8 meters; W9XAA, 49 meters; CJRX, 25-48 meters; YV5RMO, 49 meters; HJ1ABB, 41.6 meters; HBL, 31.27 meters; ONY, 49 meters; LCL, 31.45 meters; JB, Johannesburg, 49 meters; HBL, 20.6 meters relaying Vienna, Austria; WQP, 20.4 meters, and many more, of course, which I did not put down in my "Log Book." A number of South Americans were not positively identified. A Chinese station on around 28 meters mornings is R9, but it's Chinese to me! Also RW15 Siberia on 70.2 meters, but not good enough to send them a report, as static is very bad on this band. Heard several Italian ships on 70 meters early mornings.

Verifications received in August: HJ3ABD, 40.5 meters, writes—"Throw your switch at 1 p.m. and 8 p.m. to enter our advertisement contest, please send a further report mentioning some of our advertisements.

The stations with personality Apartado 509, Bogota, Colombia, S. A.

GCS, Rugby, 33.2 meters call WNA—They write "My report has been read with interest." Printed on upper part of letter reads "On-His-Majesty's-Service."

ORK, 29.04 meters, 20 kw, sends a white card with ORK in large red letters. Sent for August 2, received on August 23—very prompt reply. Radio Ruysselede, West Flanders, Belgium.

Veri from JB 49 meters, Johannesburg reads: We thank you for letter dated June 11. We are happy to advise you that you have obtained reception of our early morning session transmitted by the Johannesburg short-wave station which is devoted to physical exercises. Please accept our congratulations on your achievement.

Yours faithfully,  
AFRICA BROADCAST CO., LTD.

(This is the second veri from JB this year.)

I have heard many harmonics this month; W8XK has plenty of them on 24-26-25 meters. Also on 50.5 meters, WICG harmonic has been heard on 49.9 meters for many months here, WSB on 45 meters and many others. Amateurs have been there too; so strong that they would, for instance, blanket GBS entirely. I hear their harmonics at many places on the dial, but none of them are fooling me at all. Many of the American local short-wave stations are there today, but gone tomorrow—they play hide and seek. T2RO has not been heard this month; 59 meter band is too noisy in daylight to do any real DXing. The German stations have been sending very fine programs; also the English stations. GSB was sending a "blow-by-blow" description of a boxing bout between Johnny King and Dick Corbett for the bantam-weight championship of Great Britain, at 5 p.m. E. S. T., August 20, and received R9; QSA5. Code transmitters do the most damage to my DXing; there always seems to be two or more working on the same frequencies as the more difficult stations are to be logged. For instance ONY, most of the South Americans, Russia and even DJB have troubles. At times CT1AA, RW15, LCL, and many more like JB, CNR, I now must "train my guns" on India. Su-

# Short Wave SCOUT NEWS

matra, China, Japan, and others. I expect very good reception in the month of September.—John Sorensen.

## Official Listening Post Report From Edward Heiser, Brecksville, Ohio

● RECEPTION has been rather erratic which I believe was due mostly to weather conditions. There were a few days when the European stations came in excep-

## George Sallade Likes His Trophy



"Words fail me when I attempt to express my thanks to your magazine for such a beautiful Trophy. The Trophy was immediately displayed in a prominent Reading, Pa., store, where it was admired by many people. This, I feel, put SHORT WAVES before the public in a rather convincing manner, and at the same time helped to advertise your publication."—George D. Sallade, Winner of the Seventh Trophy Cup.

tionally loud and clear, but the period in general was not very good, because of considerable static.

T2RO in Rome, Italy, has not been heard here for the past two months, although this

## Latest "Hot" Tips for Short-Wave Listeners from our "OFFICIAL LISTENING POSTS"

station was previously heard quite regularly.

There is a new South American station located in Brazil, operating on about 31.5 meters. This station comes in very well and is usually on from about 5:30 p.m., E. S. T. Have not been able to get the call letters.

There is a Spanish speaking station operating irregularly which was heard just above FYA (25.63 M.).

At 7:00 a.m. one morning, I finally heard one of the Japanese stations. The music and speech were just understandable, but as no English was spoken the call could not be identified.

There are a few more CGA stations operating in Canada, on about 23.5 meters. These stations usually work England and use the calls, CGA2 and CGA3.

## Heinie Johnson of Big Spring, Texas, Reports

On 16 meter band we enjoy our best reception and as we predicted in our last month's report PH1 is a dandy. GSG's also mighty fine, while W3XAL is the perfect signal of the month.

The phones and commercial signals around and near this band are also good.

We turn the old dials to 19 meters and find we can hear DJB, GSF and FYA from 8 to 9:30 a. m., C.S.T.; FYA is not as good on this frequency as was the case 30 days ago. Some noise is encountered on this band and we find several mornings when atmospherics are bad, causing lots of WHIRL sound to accompany all carriers. Also, some mornings when sudden, jerky fading is noticeable. As a whole, this band is about 80% O.K.

Stopping among the amateurs on 20 meters, we got a real "kick" one night at about 8:30 p. m., C.S.T., when we heard a "KG" signal real well from Hawaii and a "G" from England. Just dumb luck—haven't been able to do it since.

Thirty days ago the 25 meter band was fine until about 11:00 p. m., C.S.T. We listened to German and English carriers as well as FYA over this frequency and they were good.

Now they are very noisy at those hours. England has been heard sending over GSD as late as 1:30 a. m., but noise kills the value of the pleasure of listening.

That Jap on 27 meters is on as usual and we finally have made out his call. It is JYM, instead of JEM as we once stated. If you hear JOAK over this frequency don't get confused. That is the local (to Japan) broadcast station they relay. We like the smoothness with which this station carrier reaches us. Must be a well "engineered" transmitter.

We haven't heard "Little America" or KNRA all month.

I believe VK3BL is now used as call number of station WK3RI, in Australia over 31 meters. Noise on this band bothers every signal but W2NAF. The Boston "carrier" has developed a really bad hum.

DX above 31 meters (lower frequency) is still very poor but will improve some in next 30 days. In that respect I want to announce the fact that there is a "real catch" to be made on 85 meters, providing you employ a good receiver and happen to get a favorable break in the weather at your location.

The station is CT2AJ located at Ponta Delgada, San Miguel, Azores, and is on 3,500 kc, every Wednesday and Saturday nights with a power of 50 watts. Hours, 6 to 8 p. m., E.D.S.T., or 4 to 6 p. m., C.S.T.

## Report From Official Listening Post of Geo. D. Sallade, Sink-ing Spring, Pa.

● NOW that there is a regular station broadcasting in the Orient the number of members in the "All-Continents" Club should increase. The new station is none other than JVM, variously reported under different call letters. In Eastern Pennsylvania this Oriental station can be heard

(Continued on page 434)



# SHORT WAVE SCOUTS

## NINTH "TROPHY" WINNER FLORIAN POESCHAL

Point St. Charles, Montreal, Can.  
162 Stations; 81 Veris

● IT gives us great pleasure this month to announce the award of the Ninth SHORT WAVE SCOUT Trophy to Florian Poeschal of Point St. Charles, Montreal, Canada. Mr. Poeschal enjoys the unique honor of having submitted the largest list of short-wave stations heard since the inauguration of our Trophy Contest nine months ago.

Mr. Poeschal submitted a total of 168 stations, 162 of which were officially OK'ed by the Board of Judges.

Mr. Poeschal used an 11-tube standard broadcast superhet, in conjunction with a 2-tube short-wave converter, both the converter and the set having been built by Mr. Poeschal himself. For an antenna he used one of the umbrella type. The list of stations was accompanied with the required notarial oath.

The list of stations submitted by the entrant in this Trophy Contest may be for any 30-day period. Keep your list of stations until you have received at least fifty per cent veris, so that you can mail the veris, list, letter, and oath all in one package. Bear in mind that the verification cards must be those received in answer to inquiries made regarding programs heard during your selected 30-day Official Listening Period. Arrange your station list in two groups, if possible, the first the *verified* group and the second, the *unverified*. State in your letter the total number of stations logged and also the number of verified ones. Before you mail your list and the veris, go before a local Notary Public and take an oath to the effect that the person submitting the list of stations has *personally* listened to the stations named. Also, state in your letter what 30-day "Listening Period" the list of stations is for.

### List of Verified Short-Wave Stations Heard by Mr. Poeschal

CT1AA-9600 kc.—See card—Lisbon, Portugal—3 Cuckoo calls.  
DJA-9560 kc.—See card—Berlin, Germany.  
DJB-15200 kc.—See card—Berlin, Germany.  
DJC-6020 kc.—See card—Berlin, Germany.  
DJD-11760 kc.—See card—Berlin, Germany.  
EAQ-9860 kc.—See card—Madrid, Spain.  
GSB-9510 kc.—See Transmission List—London, England.  
GSC-9585 kc.—See Transmission List—London, England.  
GSD-11750 kc.—See Transmission List—London, England.  
GSE-11860 kc.—See Transmission List—London, England.  
GSF-15140 kc.—See Transmission List—London, England.  
GSG-17790 kc.—See Transmission List—London, England.  
GSH-21470 kc.—See Transmission List—London, England.  
GHC-12780 kc.—In the early afternoon—Rugby, England—Phone to U. S. A.  
GRS-18310 kc.—In the early morning—Rugby, England—Phone to U. S. A.



## NINTH "TROPHY CUP" WINNER

Presented to  
SHORT WAVE SCOUT  
FLORIAN POESCHAL,  
Point St. Charles, Montreal, Can.  
For his contribution toward the  
advancement of the art of Radio  
by



Magazine

● ON this page is illustrated the handsome trophy, which was designed by one of New York's leading silversmiths. It is made of metal throughout, except the base, which is made of handsome black Bakelite. The metal itself is quadruple silver-plated, in the usual manner of all trophies today.

It is a most imposing piece of work, and stands from tip to base 22½". The diameter of the base is 7¾". The diameter of the globe is 5¼". The work throughout is first-class, and no money has been spared in its execution. It will enhance any home, and will be admired by everyone who sees it.

The trophy will be awarded every month, and the winner will be announced in the following issue of SHORT WAVE CRAFT. The winner's name will be hand engraved on the trophy.

The purpose of this contest is to advance the art of radio by "logging" as many short-wave commercial phone stations, in a period not exceeding thirty days, as possible by any one contestant. The trophy will be awarded to that SHORT WAVE SCOUT who has logged the greatest number of short-wave stations during any 30 day period; at least fifty per cent must be "verified".

### HONORABLE MENTION AWARDS

Arthur F. G. Bruder, 11 Everett St., Allston, Mass. 90S; 45V.  
Leo A. J. de Roo, Lanikai, Oahu, Hawaii. 86S; 43V.  
H. H. Kingston, Jr., R.F.D. No. 3, Rochester, N. Y. 60S; 30V.

S = Total number of stations submitted.  
V = Total number of verifications submitted.

GBU-18610 kc.—In the forenoon—Rugby, England—Phone to U. S. A.  
GBS-12250 kc.—In the early evening—Rugby, England—Phone to U. S. A.  
GBU-12290 kc.—In the early afternoon—Rugby, England—Phone to U. S. A.  
GBS-12150 kc.—In the early afternoon—Rugby, England—Phone to U. S. A.  
GBP-10770 kc.—In the late afternoon—Rugby, England—Phone to U. S. A.  
GCU-9950 kc.—In the early evening—Rugby, England—Phone to U. S. A.  
GCS-9020 kc.—In the evening—Rugby, England—Phone to U. S. A.  
GCW-9800 kc.—In the evening—Rugby, England—Phone to U. S. A.  
GDW-4840 kc.—In the late evening—Rugby, England—Phone to U. S. A.  
GBU-22300 kc.—In the morning—Rugby, England—Phone to U. S. A.  
GBC-17080 kc.—In the early forenoon—Rugby, England—Phone to U. S. A.  
GBC-13591 kc.—In the afternoon—Rugby, England—Phone to Canada.  
GBC-9310 kc.—In the late evening—Rugby, England—Phone to Canada.  
GBS-9200 kc.—In the late evening—Rugby, England—Phone to U. S. A.  
HBL-9580 kc.—Saturdays, 5:30 p.m.-6:30 p.m.—Geneva, Switzerland—Talks on the Proceedings of the League of Nations.

LEP 7790 kc.—Saturdays 5:30-6:30 p.m.—Geneva, Switzerland—Talks on the Proceedings of the League of Nations.  
LHI-17740 kc.—Daily except Tuesday and Wednesday, 7:30-10:30 a.m.—Hilversum, Holland—In the summer months.  
PKY-15070 kc.—See letter—Moscow, U.S.S.R.  
RNE-12,000 kc.—See letter—Moscow, U.S.S.R.  
HC2RL-6668 kc.—See card—Guayaquil, Ecuador, S. A.  
HJ1AB-6447 kc.—See verification—Barranquilla, Colombia.  
XEBT-6006 kc.—See letter—El Buen Tono, Mexico.  
VY2RC-6112 kc.—See booklet—Caracas, Venezuela, S. A.  
YV3RC-6150 kc.—See card—Caracas, Venezuela, S. A.  
PRF5-9500 kc.—Daily, 5:30 p.m.-6:15 p.m.—Rio de Janeiro, Brazil, S. A.  
YV5RMO-6070 kc.—Daily, 5 p.m.-10 p.m.—Maracaibo, Venezuela, S. A.  
El Prado-6618 kc.—See letter—Riobamba, Ecuador, S. A.  
HIX-6065 kc.—See card—Santo Domingo, R. D.  
LSX-10350 kc.—In the evenings—Buenos Aires, Argentina—Used for Transmission from KFZ.

(Continued on page 439)

# SHORT WAVES and

## Ethel Behm, Boys, from South Africa!



Ethel C. Behm hails all the way from King Williams Town, South Africa. She has heard all the leading short-wave broadcast stations in this and other countries on the loud speaker from a 3-tube receiver! We hope to receive photos and descriptions of short-wave listening posts as well as ham stations operated by other members of the "fair sex". So let's hear from you, ladies.

results!! I never knew what a "wallop" three tubes could have! In two nights I had all the ham "phone" imaginable on 75 meters. As I turn the dial while I write this, code stations come jumping past. In every part of the 80 meter C.W. band, there is a continuous stream of carriers from various stations. I use a 40 meter doublet antenna. Some of the 75 meter phone stations are: W1EPO, W5CR, W5AQB, W9DXI, W9BDZ, W7AXY, VE5AL, W7RY, 9COU, 4AAB, etc. Also about 250 W6's, Hi, Hi! I received all these on a loud speaker.

CLARENCE RIDGWAY,  
La Habra, Calif.

(Most interesting, Clarence, and your report on Mr. Meyer's hook-up bears out that of hundreds of other readers of SHORT WAVE CRAFT who have built and tested the Meyer's circuit. The Meyer's circuit which appeared in the April, 1933, issue of SHORT WAVE CRAFT, possesses a number of novel features, particularly the method of regeneration employed. We have heard from many users of this circuit that it is particularly smooth and reliable which coincides with the report you have given. It was one of the first to use "electron coupling."—Editor)

### Editor, SHORT WAVE CRAFT:

On the white table I have my two valve (tube) "short" wave set. On the desk is my three valve (tube) set. At the rear I have a spare Ormond set. The three valves have been giving me very good results, especially on short-waves, bringing in the following short-wave stations with loudspeaker strength: W3XAL, Bound Brook; KDKA, Pittsburgh; W3XL, Bound Brook; Daventry, Zoesen, Rome, Paris, etc. This set has also been giving perfect "DX" results, as has

the two valves on head-phones.

—ETHEL C. BEHM, care Mrs. R. F. Behm, 71 Alice Street, King Williams Town, Cape Province, South Africa.

(Pleased to hear from you, Ethel, and one thing is certain—you must have developed a very sensitive touch on those tuning dials, in order to bring in the "DX" stations on the loud-speaker, with only a 3-tube set. Let's hear from other members of the "fair sex," who are short-wave "fans" or "hams".—Editor.)

## Our 3-Tube Set Performs "Marvels"

### Editor, SHORT WAVE CRAFT:

I have been a reader of your splendid magazine for over two years and like many others I find difficulty in keeping away from the local newsstands until the 15th, always hoping that another issue might possibly come in a few days "ahead of schedule"!

I have built several of the sets recommended by your magazine, and there is one thing especially that I like about your policy, and that is that practically all the circuits published are really "practical" and not just somebody's dream of what a set should be, but isn't!

Of course, I had to build the famous Doerle, but did not secure the best results with it, due principally to not taking the proper precautions in careful building. My next effort was the Doerle "Signal-Gripper" and believe me, it showed plenty of "kick," picking up practically at will most of the European and South American stations.

About two months ago, again feeling the urge to "rebuild", I hauled out the last year's issues of SHORT WAVE CRAFT and after noting particularly the claims made by Mr. Thayer in describing his "Three-Tube DX-r that hauls them in" (I believe it was in the May, 1933, issue) and decided to see if it really performed as claimed. Believe me, it sure did! A trifle noisy and somewhat broad in tuning at times, but Oh, Boy! what "distance-getting" ability and "volume". Loud-speaker reception on amateur, police, ham, practically all the U. S. A. S-W stations and at times DJA-IJB, GSA, GSB, etc.

I have had on phones many of the L's, PR1A, YV2RC, HKD, K6XO at Honolulu, and best of all the Byrd expedition on the evening it crossed the 120th meridian at the edge of the ice pack (I believe it was at the 60th degree) and many other foreign stations which I could not identify. A peculiar thing about this set is that at times when on my 8-tube superhet "broadcast" receiver and "converter" I could get no foreign stations at all, all I had to do was to go upstairs and pull them in with this little "three-tuber"!

Back in the days of the crystal sets and Copp circuits, I used to read articles in Radio News, etc., by our friend, Editor

Hugo Gernsback, and when he started the present SWC, I knew that he saw possibilities in that field and I followed and I have ever since been glad I did.

L. DURAND,  
14804 Ardenall Ave.,  
East Cleveland, Ohio.

(Hot stuff, L. D. R., and it really is surprising what a "good" 3-tube receiver, such as Mr. Thayer's, can do when carefully operated. The most astonishing thing, of course, about the whole performance in your case is the fact that the 3-tube set completely outdid the 8-tube "broadcast" receiver, plus the short-wave converter, which is rather unusual to say the least.—Editor)

### ROCKETS, SIR, FOR MR. MYER'S SET

#### Editor, SHORT WAVE CRAFT:

I started reading SHORT WAVE CRAFT in April, and since then have not missed a single copy. First I constructed the Oscilodyne, then, the 2-Tube Doerle, and had fine success with the both of them. When I again looked in my April issue, I saw Mr. Myers' set and decided to build it. What

### One Year's Subscription to SHORT WAVE CRAFT FREE

for the "Best" Station Photo

Closing date for each contest—60 days preceding date of issue; Nov. 1 for Jan. issue, etc. The editors will act as judges and their opinions will be final. In the event of a tie, a subscription will be given to each contestant so tying.

### W3BYK "WORKS" ALL COUNTRIES

#### Editor, SHORT WAVE CRAFT:

Recently you requested photos of short-wave stations; here is mine. The transmitter consists of a 47 xtal osc., 210 freq. doubler and a 205A final amplifier with 450 watts input. The receiver is a home-built superhet and works real well. Antenna used is a half-wave voltage-fed Zepp. Frequencies used are 7016 and 7294 kc. All U. S. and VE districts, Germany, Spain, Cuba, and South America have been "worked." Your magazine is a real Ham publication and I certainly enjoy reading every copy. 73.

STANLEY M. LADAGE, W3BYK,  
923 N. 27th Street,  
Camden, N. J.

(A peach of a station and the fact that you "worked" foreign countries shows that you must have the transmitter "perking" at 100 per cent plus.—Editor.)

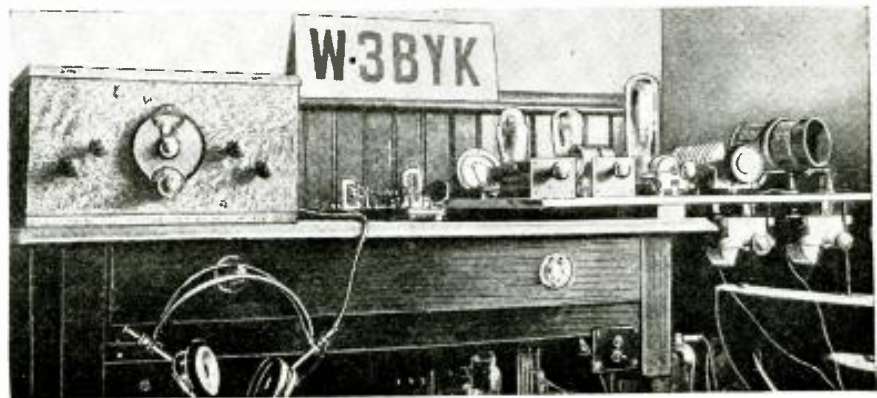

Here's a snappy American "Ham" station operated by Stanley Ladage of Camden, N. J. His call is W3BYK.



# LONG RAVES . . . OUR READERS' FORUM

## BOY! WHAT RESULTS! FROM A "JUNK-BUILT" OSCILLODYNE!

Editor, SHORT WAVE CRAFT:

I feel I owe you and especially to Mr. J. A. Worcester, Jr., an apology, for nailing some old radio parts together and calling them an *Oscillodyne*.

Some years ago, living in New York City then, I had lost all interest in short waves. An occasional squeal and plenty of interference were about all my results. But I always tried to keep informed of the happenings in the short-wave field by reading your publications. And now, during this winter, living up here in a rural district of the Adirondacks I could not resist the temptation to try my luck once more, since from an old copy of *SHORT WAVE CRAFT* I had become interested in the *Oscillodyne* circuit.

And so I took an old *Pilot Wasp* set apart and fixed the new set up. I actually *nailed* it together, since the next place to get radio parts is about 60 miles from here, and besides, who wants to go there with the thermometer anywhere below—25°F. and 3 feet of snow on the roads? And where it was impossible to make the connections in the set with nails and small screws I just wound the wires around the binding posts and *squeezed them tight with pliers!* To get the set going I took an old 201 tube, my car battery and an old 45-volt B-battery I found somewhere standing around at a neighbor's place. I assure you all three had seen plenty of service before. The antenna is a 10-foot piece of wire dangling from the set, just the right size to fall over when I get off my chair—the piece the telephone men forgot when they connected my telephone had been longer, but I used a part for hooking up the set. The ground connection goes to the lightning fuse of the telephone.

And with this outfit—I really hesitate to call it a short-wave receiver—I pulled in during about 4 hours after the set-up:

FYA, EAQ, GSC, DJA, GSB, PSK, YV3BC, WSXK, W3XAL, W9XF, VE9GW, DJC, and numerous domestic "hams", airplane, telephone, and broadcast stations to which I did not pay any attention as I was out for "blood".

And I had lost my interest in short waves, with such a set available since almost a year—what a pity!

KARL F. STEGMANN,  
Poultry Farm, Route 2,  
Corinth, N. Y.

(Boy, oh boy! What a set—and what results! Mighty pleased to hear from you Karl, and it just shows what a "kick" the *Oscillodyne* receiver has in it, when it rolled up the score you cite, with the receiver thrown together from "odd parts." We are glad to know that the *Oscillodyne* revived your interest in "short waves" and if you have been listening to some of the recent fine European musical and vocal programs from England, Germany, France, and Italy (not to mention Russia and a few other countries), as the editors have been doing—you have certainly experienced a mighty big treat.—Editor)

## PROUD OF HIS "DOERLE" RECEIVER

Editor, SHORT WAVE CRAFT:

I have been a constant reader of your magazine for over a year and have just a short while ago become the proud possessor of a 2-tube *Doerle* battery type receiver. A few weeks ago I added another tube to it, making it a *three-tuber* and although I haven't logged VK2ME or VK3ME (Australia), I still have a good long list of stations. Here are some of the stations I've heard:

HJ1ABB, Barranquilla, Colombia.  
HC1DR, Quito, Ecuador.  
HC2RL, Guayaquil, Ecuador.  
PSK, Rio de Janeiro, Brazil.

## Mr. Wadia of Bombay, India, "Logs" 119 Stations

"Prize-winning" station photo awarded One year's subscription to *SHORT WAVE CRAFT*.



One of the best-known "short-wave listening stations" is that of D. R. D. Wadia, a lawyer of Bombay, India, who sends us this picture of his short-wave "radio den."

Mr. D. R. D. Wadia, Bar-at-Law of Bombay, India, in his "Radio Den" from where he sends out reception reports to *Short-Wave* and *Broadcast* stations all over the world. His *veris* include such difficult catches as LSX, WSXK, W3XAL, W2XAF, WGY. He has also logged all the Gs, Fs, Ds, VK2ME, VK3ME, YUB, YUC, YU2BY, YU2BY, YUGAH, J1AA, JYT, RV59, RNE, REN, HVJ, 2RO, EAQ, PCJ, PHH, VQ7LO on the short waves and innumerable fones like KAY, G6RX, most of Java, RIM, RKL, Cairo, Teheran, Paris, Rugby, and practically all the European broadcasters having over 20 kw. power.

The only radio that has given him entire satisfaction and 99 per cent reliability is the Philco 11 tube All wave Superhet and he has used many famous makes.

His interest in radio dates back to 1921 and he is a member of the I.S.W.C.; A.R.R.L.; S.W.L.; R9 L.L.; R.B.S.W.C.; N.Z.S.W.C., etc.

*Short Wave Stations heard*—GSH, IRW, PMA, PLE, GAU, PCK, PZS, PMC, PCV, GSC, W3XAL, PHH, IAC, VWY, JYT, RIM, FYA, DJB, GSF, HVJ, RKL, KAY, GBW, SUZ, JYK, IAC, GBC, PLM, PDV, RNE, FZS, FYA, WSXK, GSE, I2RO, DJD, GSD, PHH, FYA, PDK, LSX, PMN, STV, EAQ, J1AA, IRM, VK2ME, GSC, DJA, VK3ME, GSB, PLW, PLV, VSW, YUB, IAC, HSJ, RIM, RKL, MEDAN, IAC, REN, ZGE, PK1WK, YUC, VQ7LO, DJC, RV59, HVJ, G6RX, RV15.

LSX, Buenos Aires, Argentina.  
HSJ, Geneva, Switzerland.  
I2RO, Rome Italy.  
KNRA, Schooner "Seth Parker".  
KEE, California.  
KEZ, California.

I have also received "amateurs" from Mexico, Porto Rico, and the Pacific Coast. I am using a single-wire aerial about 100 feet long and with a single wire lead-in. I want to tell you people I enjoy your magazine very much and will continue to do so.

*Broadcast and Long Wave Stations heard*—Algiers, Bari, Belgrade, Bratislava, Breslau, Brno, Budapest, Bucharest, Cracow, Deutschlandsender, HFI, Frankfort-on-Main, Goteborg, Graz, Heilsberg, Istanbul, Kahlundborg, Katowice, Langenberg, Leipzig, Leningrad, Ljubljana, Luxemburg, Luow, Milan, Moravska, Ostrava, Moscow, Motala, Munich, Naples, Oslo, Poste Parisien, Prague, Sottens, Reykjavik, Rome, Beromunster, Stockholm, Strasbourg, P.T.T., Stuttgart, Toulouse, Trieste, Turin, Wien, Warsaw, Wilno, W.G.Y. Total 119. Heard since 1924.

(The editors are happy indeed to hear from our foreign readers and Mr. Wadia, who is very well-known to short wave fans in many countries, deserves a lot of credit for the very thorough short-wave listening job he has done. Mr. Wadia is a "dyed-in-the-wool" short-wave "Fan." He never lets a day go by but what he listens in to some of the leading short-wave stations.—Editor.)

## OSCILLODYNE A "HIT"!

Editor, SHORT WAVE CRAFT:

Just a line to let you know that I am enjoying your *SHORT WAVE CRAFT* magazine better every issue. I've managed to get it since Vol. 3—No. 1, except three issues in Volume 3, which I missed. I think your magazine is F.B. (Fine Business). The "fiction" tales are great and would like to see more of them.

(Continued on page 441)

GEORGE DEMMITT,  
919 N. Pine St.,  
York, Pa.

(Again the *Doerle*! Well, George, the *Doerle* fans seem to have the "DX" (long distance reception) situation well in hand and, judging from the thousands of favorable reports received in the past few months regarding phenomenal reception results with the *Doerle* sets, you will most probably have logged VK2ME or 3ME by the time you read this in print.—Editor)

# Which AUDIO Should I BUILD?

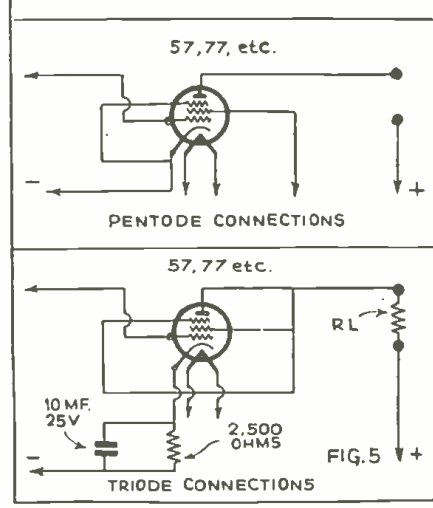
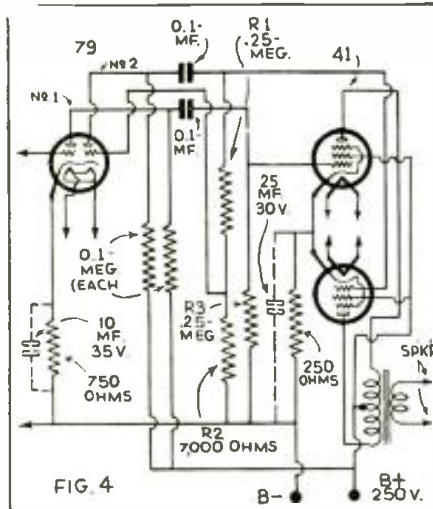
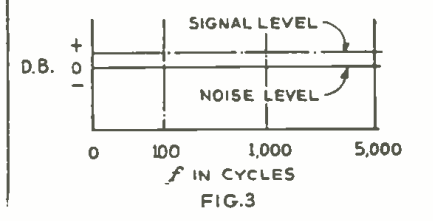
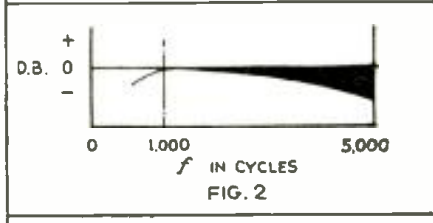
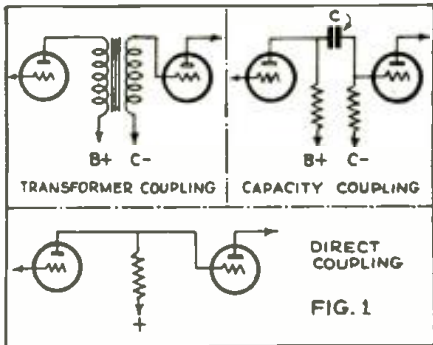

Diagrams, above, show transformer coupling; capacity coupling; direct coupling; curves giving relation of noise caused by drooping characteristic; push-pull circuit, and finally pentode and triode connections.

• SO MUCH material has been printed on the radio amplification and detection end of short-wave reception, that it seems as though some attention should be devoted to the A.F. (audio frequency) circuits of these popular receivers.

Every one is familiar with the three common forms of audio couplings. They are transformer, capacity and direct-coupled as indicated in Fig. 1. Some readers will say that capacity-coupled circuits are called resistance-coupling but, like many other radio terms and popular definitions, we find them wrongly stated. An examination of the circuit indicates that the actual coupling means is the capacity C.

There is one thing in the mind of the short-wave "receiver" constructor, and that is to obtain the maximum signal strength with the smallest possible number of parts and tubes.

Several applications of the tubes available on the market today offer excellent possibilities in the above respect.

### 4 Important Factors!

Let these factors be considered when planning audio frequency amplification for short-wave receivers.

- 1—Voltage Amplification Required.
- 2—Power Output Required.
- 3—Power Source. (A.C., D.C., Battery.)
- 4—Frequency Range Required.

The voltage amplification required in short-wave receivers will be dependent on the voltage output of the detector and the voltage necessary to swing the grid or grids of the output tubes. The solution of the problem can be worked out quickly by studying the tube characteristics and then using the DB method of calculating the necessary gain. However, many short-wave receiver con-

structors are not familiar with the DB unit, and for that reason several combinations will be given which will fit in with most of the receivers in use today. Select the circuit that fits in with your requirements.

The power output will depend on the desire of the set builder, the room and the purpose for which the receiver is used. This final stage can increase the cost of the short-wave receiver considerably. Larger power transformers and high voltage filter condensers are costly and for that reason output tubes are chosen for their economy and power output. The factors mentioned above tend to make the pentode type of output power tube very popular. Tubes like the 47, 2A5, 59, etc., are ideal for the purpose. In every case the tubes are used in a Class "A" connection and as Class "A" power tubes. Class "B" with its grid power requirements demands good power supply equipment and additional audio amplification. Balancing the cost of Class "B" versus Class "A" operation, one finds that Class "A" operation is the cheapest and most satisfying in the end. Of course, pentode type output tubes offer the greatest value, although the total distortion will be greater than that which would be obtained from triodes such as the 45 type tube. It is not necessary to obtain a higher degree of fidelity than that obtained from a properly matched pentode dynamic-speaker combination, working below the point of grid current in the output stage. The ability of the output tube to develop around three watts should satisfy most requirements, as it is possible that most of the voltage applied to the grid of the output tube will consist of noise anyway. The author

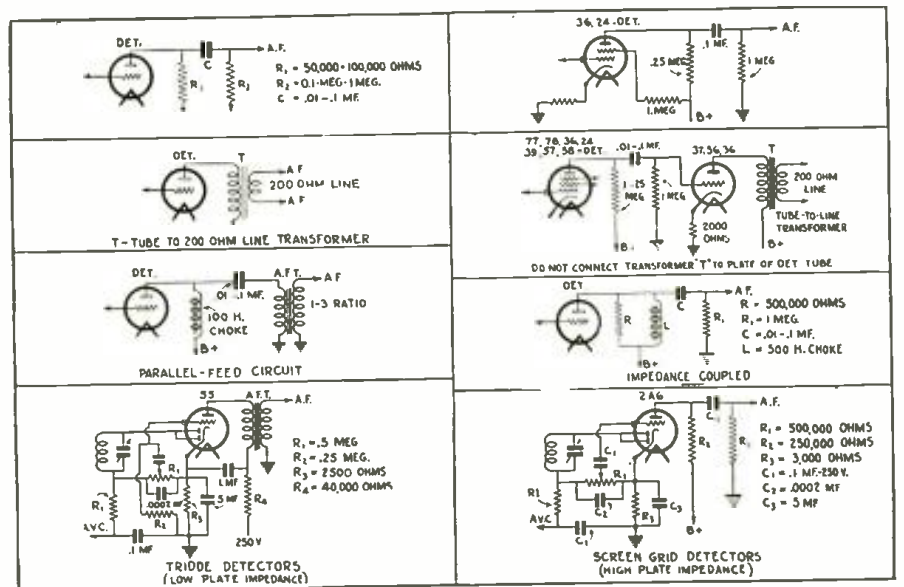

Fig. 6, above, shows various methods of coupling the output of a short-wave receiver to an audio amplifier.



# AMPLIFIER

By **CLIFFORD E. DENTON**

has listened to many sets where the total output was two watts, while the effective signal was about .05 watt. This reception is not pleasing to say the least and such noise levels do not justify great power output.

### Power Supply

The power supply units will depend on the line power supply available. In some of the bigger cities D.C. will be found while the greatest majority of homes are A.C. supplied. Battery and 32 volt operation will be found on the farms in many sections. Therefore the power supply unit will depend entirely on the available line power supply. The new tubes permit excellent operation to be obtained from A.C. and D.C. circuits and genemotors (dynamotor) are available for operation on 6 volt batteries or 32 volt farm lighting plants. Remember, power output requires power and voltage for the plate of the output tubes and to obtain 3 watts of power from the receiver with tubes on the market today, that at least 250 volts on the final stage is necessary.

### Audio Frequency Range

The audio frequencies necessary for music and speech can be confined to the range between 100 and 4,000 cycles. In many short-wave receivers of the high gain type it is advisable to have the audio cut-off below 4,000 cycles due to tube noise and the hash of interference and static which accompanies long distance reception. In some receivers the audio system has been designed to give a drooping characteristic above 1,000 cycles. The shaded portion of Fig. 2 indicates the effect of this characteristic on the noise picked up by the receiver.

Suppose that the output curves of Fig. 3 are correct for a given short-wave receiver, that is, the signal overrides the noise. The response of the receiver to the signal and the noise throughout the audio band will hold the same relationship. From the above, then for any given portion of the audio band, there will be a given amount of noise amplification. The greater the audio range of the receiver, the greater the noise in the output. The narrow audio band will amplify the noise to a lesser degree and if the frequencies up to 2,500 cycles are amplified, speech will be understandable and music reproduction will be passable.

This lack of quality, in so far as frequency response is concerned in present-day short-wave receivers, is accepted as a "necessary evil" at the present time. However, improvements in antennas and tube circuits, plus the use of *highly selective* tuned circuits, will result in high fidelity reception at short-waves. This day is not here and will be some time in coming.

So many readers of *SHORT WAVE CRAFT* have asked for this information, the editors tell me, that special mention must be made of this interesting circuit. Of course, push-pull transformers are costly and now that the tubes like the 79 are available, transformerless push-pull stages can be built by anyone.

A study of the diagram of Fig. 4

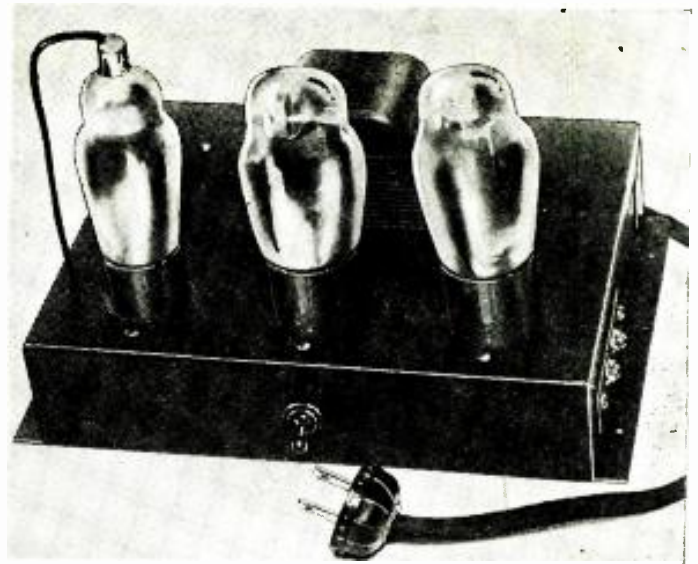

Appearance of finished audio amplifier, shown diagrammatically in Fig. 7.

shows how this "push-pull" action is accomplished. The signal from the detector is applied to one of the grids of the 79, and the resultant amplified signal capacity coupled to one of the output tubes. The grid of the remaining triode section of the 79 is connected to the voltage-divider, made up of resistor, R1 and R2. The signal voltage applied to the grid of the No. 2 triode section of the 79 will be 180 degrees out of phase with the original signal voltage applied to the grid of the No. 1 triode section of the 79. As the effective MU of the 79 with the recommended load resistance is 35, and for reasons of symmetry R1 plus R2 should equal R3, it will be noted that the voltage across the resistor R2 (7,000 ohms), will be equal to the voltage on the grid of the input triode section. The voltage across R2 is one thirty-fifth of the voltage across R1 and R2. This results in a voltage on the grids of the output tubes equal in value and of the proper phase relationship for "push-pull" action.

The condensers indicated by dotted lines are not necessary ordinarily, as

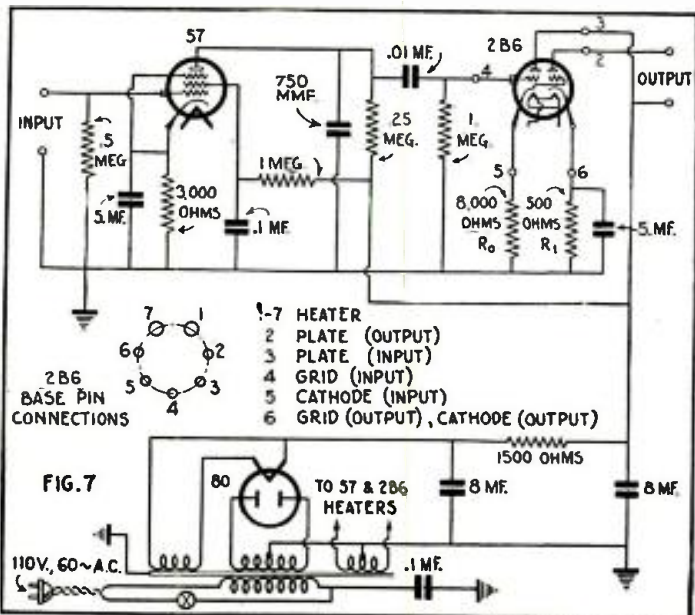

Fig. 7—Showing the use of the new 2B6 tube. A "high gain" four to six watt audio amplifier.

The editors have been looking for a good AUDIO-AMPLIFIER article for some time. Mr. Denton, well-known radio engineer, has, we believe, covered this subject in a very complete and authoritative manner and we are sure that our readers will be glad indeed to have this valuable information placed before them. Mr. Denton discusses the various factors we must watch out for in designing and building an audio amplifier suitable for use with a short-wave receiver, which is quite a different problem than designing such an amplifier for use on a broadcast receiver.

the tubes are operating in a push-pull connection. In cases of electrical unbalance of the tube elements or resistors, such condensers may be useful. The gain of such a circuit is such that one

volt from the detector will give ample output volume. A power output of 6 watts can be obtained with a total distortion of 11 per cent. This is entirely satisfactory for short-wave receivers.

### Pentode Tubes As Triodes

In many circuits the "possible" amplification of 77's or 57's cannot be (Continued on page 442)

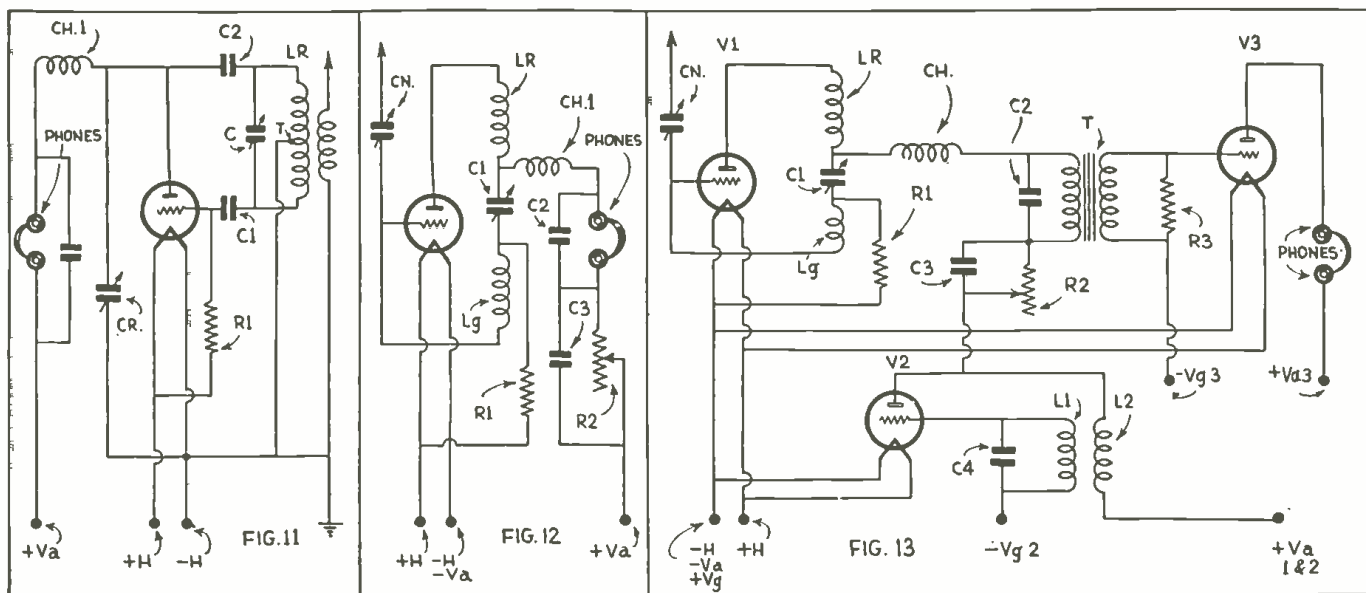

Fig. 11. left, shows ultra-audio 3 meter receiver circuit; Fig. 12. circuit improved by connecting tuning condenser in series with inductance; Fig. 13. detector and 1 stage of audio amplification, with V2 providing the low frequency oscillation, making it a super-regenerative receiver.

# 3.1 Meter RECEIVER

By DR. W. MÖLLER, Germany

● THE receiver described is not a result of countless experimentation and, therefore, there is no reason to insist that it is the best. However, it can be stated without exaggeration, that it operated excellently during our experiments on 3-meter waves over long distances. Similarly to the oscillator, the circuit of this receiver is also based on the Hartley three-point circuit shown in Fig. 1. (Part I, in last issue.) Such receivers in which the oscillatory circuit is located between the grid and plate and not between the cathode and grid are called ultraaudions. This arrangement is shown in Fig. 11. The grid-leak, R, and the by-pass condenser C have the usual values of regenerative receivers. The inductance coil of the oscillator circuit has a tap, the position of which depends upon the amplification constant of the tube. The plate end of the coil LR insures the feed-back action. The R.F. choke CH1 and the by-pass condenser C2 separate the R.F. currents from the A.F. currents. Cr controls the amount of regeneration. When Cr increases a larger part of the R.F. current is shunted to the ground and the feed-back becomes less. The opposite is true when the capacity of Cr is decreased.

However, this circuit is not well adapted to operate on very short wavelengths. First, the inductively coupled antenna is very inefficient in the range of the above wavelengths. Only an antenna coupled directly through a small capacity to the H.F. generator can be taken in consideration. Secondly, it will be too difficult to tune in to very short waves with a condenser connected across the inductance. It is preferable to put the condenser C1 in series with the inductance, as shown in Fig. 12. With such an arrangement, condensers C2 and C1 of Fig. 11 are not necessary and are omitted. The regeneration is very satisfactorily controlled by adjusting the plate voltage with a series re-

In the Sept. issue the details of the 3.1 meter transmitter were given; in the present article the details of the 3.1 meter super-regenerative receiver are discussed.

sistance R2. The variable neutralizing condenser Cn, connecting the antenna directly to the grid has a maximum value of 20 mmf. The oscillatory circuit Lr, C1, Lg contains in series also the plate-to-grid capacity C<sub>ga</sub> and therefore C, can be relatively large without increasing very much the total capacity of the circuit. The R.F. choke CH, which cuts off the R.F. currents from the headphones can be replaced by a corresponding filter.

The sensitivity and the loudness are considerably increased by adding a local oscillator to the above circuit, and a one or two stage A.F. amplifier. The object

of the local oscillator is to superimpose upon the normal plate voltage of the regenerative tube, an R.F. potential and thus amplify the sensitivity of the tube. This phenomenon can be explained in the following manner: An increase of the D.C. plate voltage in a regenerative receiver reduces the damping of the oscillatory circuit and naturally increases the sensitivity. However, the direct current plate voltage can only be brought to such a point where the tube is near the oscillation state. By approaching the critical point of zero damping of the oscillatory circuit, the operation becomes unstable. The slightest cause, even the smallest variation of the plate voltage supply is sufficient to set the tube in oscillation and make impossible any reception whatsoever. When an R.F. voltage superimposes on the D.C. plate tension, the value of the latter can be so adjusted, that during the positive half-cycle the resulting plate voltage surpasses the critical point, while during the negative half-cycle the combined voltage is way below this point. The plate voltage oscillates around the critical point and the result of this is an enormous increase in the sensitivity of the tube. Unfortunately this method has its drawback. Although this type of plate voltage variation is of the R.F. order and therefore cannot be intercepted with the ear-phones, the receiver has a certain peculiarity: the background of the received tone is never so "clean" as in ordinary regenerative receivers.

Because a certain number of tests were made with the receiver, the circuit of which is given in Fig. 13, details are given below about the separate parts. The tube V1 and its corresponding circuit are the same as in the circuit shown in Fig. 12. If a tube of the 112 type is used, the oscillatory circuit will be in resonance with the incoming wave of the transmitter, when Lr has two turns

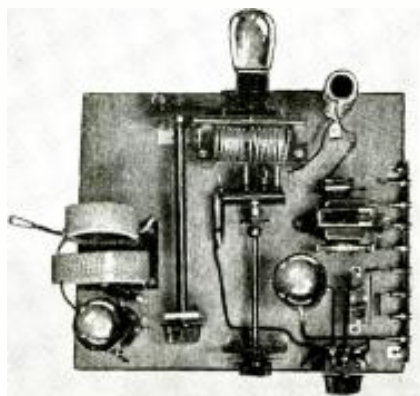

Fig. 14—Appearance of finished 3-meter receiver using 3 tubes.

(Continued on page 447)



# “Break-In” Monitoring

By DONALD McKINLEY,  
VE3AU

This is a very clever idea for a break-in system to be used at amateur transmitting stations; the “home” signal blocks the regular detector but comes through on the monitor circuit into the phones. When an “outside” station signal comes in on the aerial it “clears” through the regular detector and the operator hears the station “breaking in”.

• LISTENING in on your own transmitter by means of the monitor or frequency meter is recognized as one of the best aids to better sending and improved operating. However, many amateurs claim that the delay and bother necessary to transfer the phones from the receiver to the monitor and switch the latter on and off after each transmission offsets this advantage.

Again, and this applies especially among the traffic handlers, the practice of working “break-in” or duplex is becoming more prevalent. Whenever break-in operation is employed the transmitters and receivers in both stations are in continuous operation; and whenever one operator misses a word of the message he has only to press his key to stop the other, who then repeats the word and continues. This method also prevents those long five minute calls since the called operator has only to send the characteristic signal “BK” to inform the calling operator that communication has been established.

A combination of these two operating procedures is, of course, to be desired but few amateurs seem to be using it. The following scheme of break-in moni-

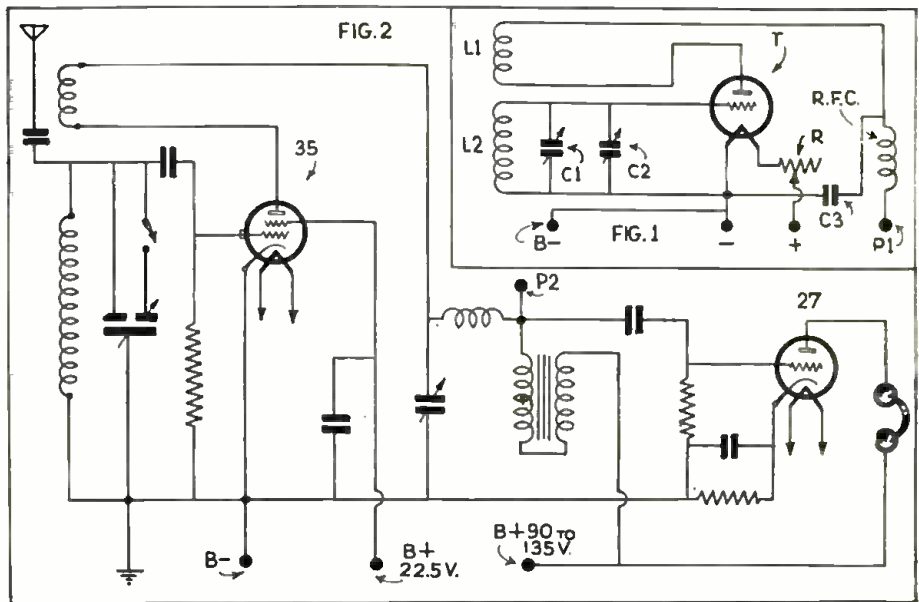

Circuit for the clever “break-in” monitoring system here described by Mr. McKinley, which permits hearing the “home” signal and also a “break-in” signal from an outside station.

toring has been employed at this station for nearly a year and has given very satisfactory results.

The monitor (Fig. 1) is the typical oscillating frequency meter: its fundamental frequency being in the 160 meter band and the second, fourth and eighth harmonics used to check up on the transmitter in the usual way. The accompanying reference table gives the various values of inductance and capacity.

It will be found that the trimmer condenser C2 will be set at about full capacity, which, incidentally, helps to provide that Hi-C tank which is quite as important for frequency stability in monitors as in transmitters. The meter

is calibrated by the zero beat method and the trimmer may be adjusted slightly from time to time if the dial readings should happen to slip from the calibration curve. A D.C. “battery” tube is used because the A.C. tubes seem to modulate and fail to give a faithful reproduction of the signal from the transmitter. However, if perfect fidelity in the reproduction of the transmitter note is not required, a 227 tube may be substituted for operation from the receiver filament transformer.

The receiver at this station is typical of the usual home-made job (Fig. 2) but the principle of break-in monitoring can be applied to almost any receiver.

(Continued on page 436)

## A Home-Made Condenser “Mike”

• FOR broadcasting or recording work the condenser mike has hardly any equal and, in fact, is considered by those who should know to be the best type of microphone obtainable.

When compared with the carbon type of mike the most important item of interest where high quality is concerned, is the lack of back-ground noises. The “frying carbon hiss” which is generally associated with that of carbon mikes being entirely absent from the condenser mike, giving the clear bell-like response which can be detected instantly by anyone having had experience with high quality microphones.

The writer has experienced trouble, due to the remarkable sensitivity of the mike; the trouble was in the nature of echo effects, due to the room not being acoustically designed for the purpose.

In the average amateur’s shack such troubles are to be experienced unless special precautions are taken to deaden the echoes; usually a number of blankets, or heavy curtains, hung around

the room, will prove to be quite satisfactory.

### Construction of Microphone

The drawing clearly shows the various parts used in the construction of the microphone and all the important measurements are given. It must be stressed, in the construction of an instrument of this type, that extreme care be taken in all machine work in order that good tone quality will be obtained. The diaphragm must be stretched carefully and it must be free of nicks or wrinkles. The material used for the diaphragm is either tin or aluminum

foil .005 inch thick; lay it on a clean piece of glass and rub with a piece of cloth until free of any irregularities. The gaskets are made of three thicknesses of paper about as thick as this page.—*Australian Radio News.*

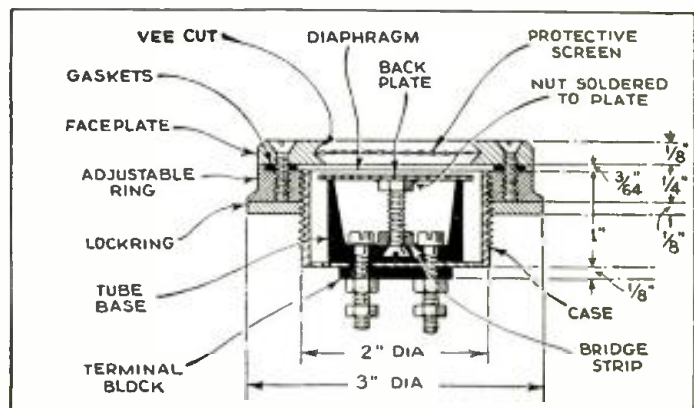

This drawing shows how to make a first-class condenser microphone.

# WHAT'S NEW

The short-wave apparatus here shown has been carefully selected for description by the editors after a rigid investigation of its merits.

# In Short-Wave Apparatus

## FUN With 5 - Meter Trans - Ceivers!

By FRANK LESTER, W2AMJ\*



The author operating the 5 meter Trans-Ceiver. (No. 215.)

• THE most interesting piece of apparatus in amateur radio at the present time is the five-meter "transceiver," which gets its name from the fact that it is a combination transmitter and receiver using the same tubes and accessories for both purposes. A recent ruling of the Federal Communications Commission permitting mobile as well as portable operation on five meters has greatly accelerated amateur activity along these lines, and amateurs everywhere are deserting the hopelessly crowded 20-, 40- and 80-meter bands to find considerable pleasure on the shorter waves.

Five meters is a lot of fun because you can pack a complete outfit into a box about the size of a typewriter case and set it up for operation in about fifteen seconds. You can operate it in a car in motion, and contact dozens of different "hams" as you drive from one town to another. Five-meter "field days," held on Saturdays or Sundays, are getting to be regular affairs in amateur circles.

In recognition of this growing acclaim of five meters, the writer has designed a three-tube transceiver that has

\* Engineer, Wholesale Radio Service Co., Inc.

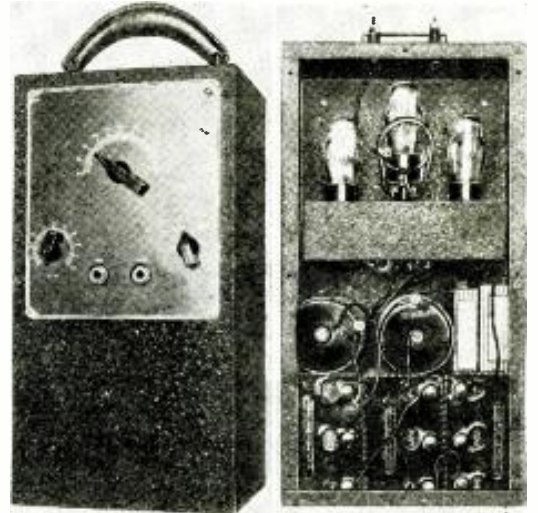

Front and rear view of 5 meter Trans-Ceiver.

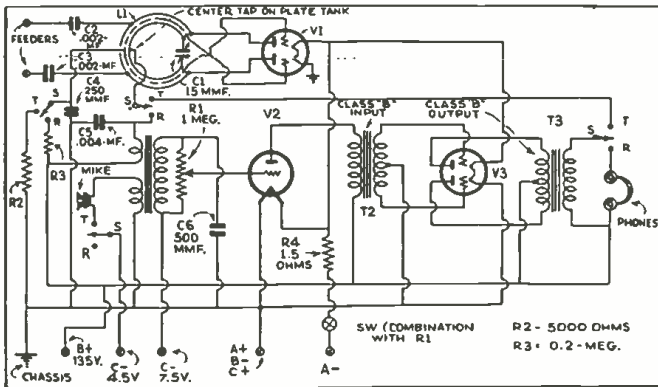

Diagram of 5 meter Trans-Ceiver, showing novel use of the 10 tube.

houses the complete outfit, which is known as the Lafayette Transceiver. Why steel and why not aluminum for a portable job? The writer has found that steel stands the punishment of portable service better than aluminum does, and its extra weight pays for itself in durability.

As shown in the illustrations, the case is formed on four sides and has removable front and back panels. A "man-sized" carrying handle is fastened to the top. The upper half of the box is occupied by the transceiver proper, the lower by all the required filament and microphone batteries. A decorative plate for the front panel carries three controls and two jacks; the former are the main tuning knob, in the upper center, volume control, lower left, and receive-transmit "throwover" switch, lower right. The jacks are for earphones and a small hand microphone.

The knobs are of the new pointer type and look very distinctive. A plain knob and not a vernier dial is used for the tuning condenser (C1 in the diagram) because the tuning is not critical

(Continued on page 425)

proved exceptionally successful. A description of it will undoubtedly interest readers of SHORT WAVE CRAFT, as it contains some unique features of design and construction.

A single case, made of steel finished in durable black crackle and measuring 15 1/4 inches high, 8 inches wide and 7 inches deep,

## New Pre - Amplifier Helps Weak "Sigs."

• THIS supertone booster uses two tubes, one type 6D6 in a stage of tuned R.F.

and a 25Z5 as the rectifier. It can be added to any short-wave receiver from a one-tube battery set to a multi tube superheterodyne. When applied to a superheterodyne it will increase the sensitivity of the set and reduce image response to a minimum and in this role it is called a pre-selector. Plug-in coils are used and it covers a range of 15 to 200 meters. A volume control is incorporated in this R.F. amplifier in order that various amounts of gain can be obtained. With the proper adjustment of this volume control, together with the volume control of the set with which it is used, background noise can be reduced to a lower level than can be obtained without a pre-selector stage. The volume control is the right-hand knob. This booster is self-powered, obtaining its filament and plate voltages directly from the 110 volt A.C. or D.C. line. Sufficient filtering is used to render the pre-selector humless. It is housed in a neat black crackle-finished case slightly over seven inches square. The output of this booster connects directly to the antenna and ground post of

the receiver with which it is used. Complete details are given in the circuit diagram as to values of parts, etc.

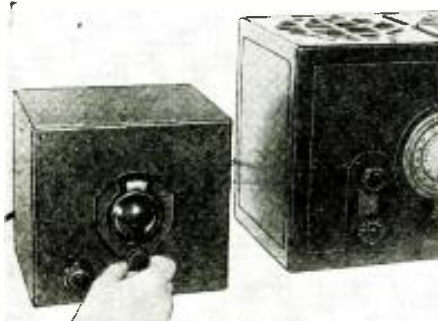

The new Supertone "Booster" or pre-amplifier. It will intensify the signal when used with any set from 1 to 10 tubes. (No. 216.)

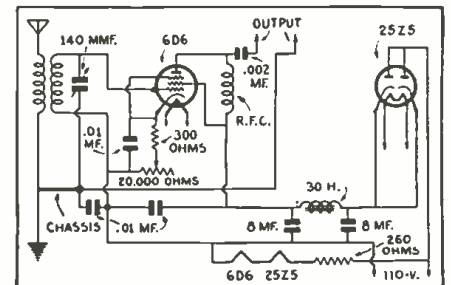

Wiring diagram of the Supertone "Booster".

Names and addresses of manufacturers of sets described on this and following pages furnished upon receipt of stamped envelope; mention No. of article.



# A New Sensitive Constant Band-Spread Super-het

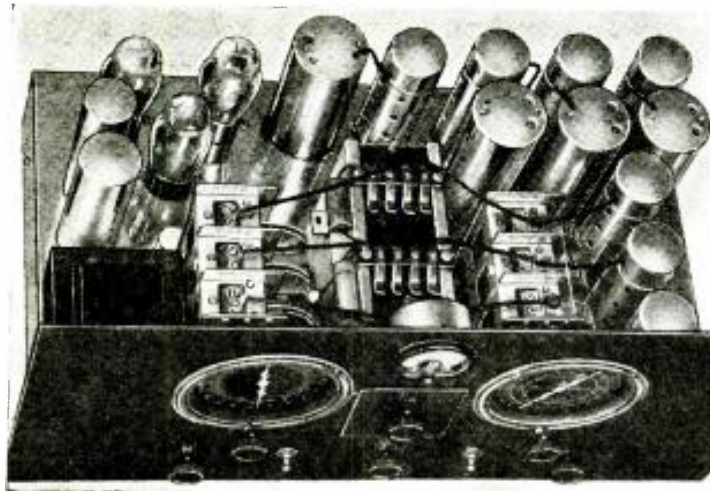

Right — The handsome appearance of the new Postal Model 35, 10-tube all wave super-het. (No. 213.)

Left — Note the massive construction of the new Postal 10 - Tube Constant Band - Spread All - Wave Super. It has accurately calibrated dials.

Below — Diagram of the new 10-tube Postal Super-het; it has "beat oscillator" and "A.V.C."

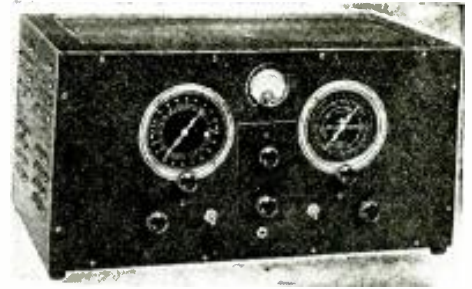

by the well-known Postal "draw method." This draw is inserted directly in the center of the panel between the two large tuning dials. The dial to the left of this drawer is the *band-spread* dial and the one to the right is the *general-coverage* or *band-setting* dial. This dial is calibrated, showing the operator at all times in just what frequency range he is working. These illuminated dials are beautiful 4½-inch diameter affairs having suitably high ratio. The *continuous band-spread* arrangement makes it possible to have band-spread at any par-

(Continued on page 434)

● THIS new Postal Model 35 receiver is complete in every detail and is truly a versatile receiver. It can be used for amateur work where extreme selectivity and stability are required. It has a beat-oscillator which provides CW reception. The large amount of band-spread incorporated in this receiver design of course makes it an excellent receiver for the short-wave "fan" who listens in on the various short-wave "broadcast" (speech and music from Europe, etc.) bands. These bands are spread over the dial to such a degree that tuning is as simple as that of a broadcast receiver. A pre-amplifier stage, that is, the stage of tuned R.F. used ahead of the first detector, practically eliminates image response and improves the over-all gain of the set. The photograph clearly shows the beautiful crystal finished metal cabinet in which the receiver is built. The various bands to which this receiver will tune are changed

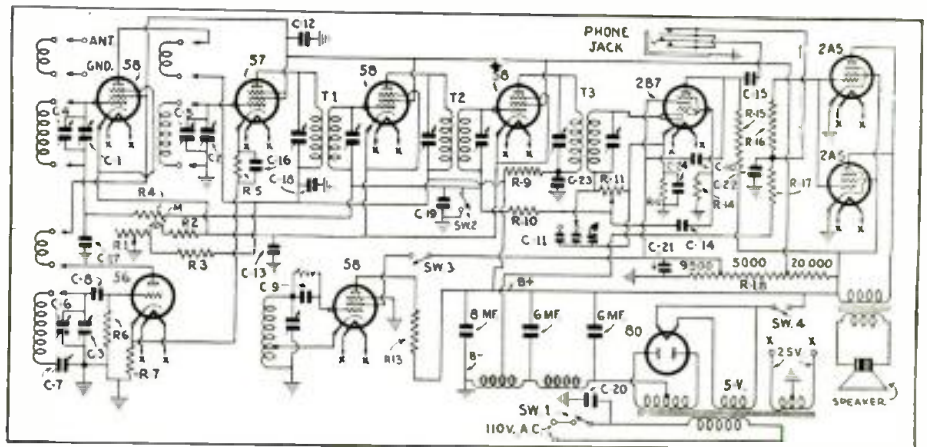

## New HI-FI Antenna System

● UP to the present time most *all-wave noise-reducing antenna systems* have been deficient in signal strength on the *broadcast* band. In some systems a compromise has been made with noise by including a switching arrangement which converted the antenna from a doublet with noise-reducing properties to an ordinary "T" antenna with no noise-reducing properties. It had been though impossible to provide an antenna system which would be efficient over the very broad band of frequencies which lie between five meters and six hundred me-

The drawings at the right show the general arrangement of the new Lynch "HI-FI" Antenna System. This is good for noise-proof reception on all wavelengths. Circuit diagram of the coupler, together with the physical drawing, shows complete details. (No. 214)

ters, which is equivalent to fifty-six thousand to five hundred and fifty kilocycles.

The ordinary broadcast receiver has a frequency ratio of approximately three to one. The new Lynch antenna systems have a frequency ratio of more than forty to one.

Where suitable space is available an entirely different type of antenna is suggested having a total overall length of one hundred and fourteen feet which is approximately half a wave-length at seventy meters or 4.3 megacycles. With this type (Fig.

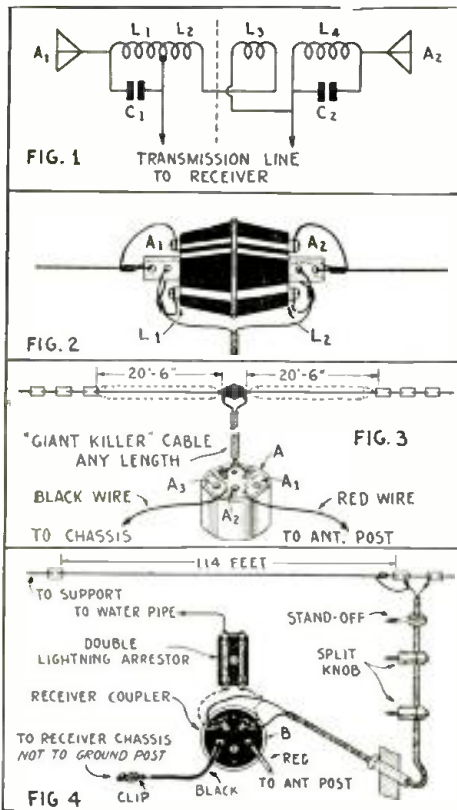

4) of horizontal antenna the lead-in is taken from the end rather than in the center. This has been done as a matter of mechanical convenience rather than electrical efficiency. This system is known as the *Complete Lynch "HI-FI" Simplex System*.

The latter system does not require the elaborate and rather expensive antenna transformer and where space is available it is recommended as being superior to the doublet type. As is true with the Duplex system (Fig. 3), the flat top need not be in a straight line. It may zig zag, but it should not double back on itself.

Most of the important short-wave broadcast stations operate on approximately 13, 16, 19, 21, 31, 49 and 70 meters. A long horizontal antenna cut to receive on 70 meters is fairly efficient on all of the other wave-lengths and it is extremely good in the broadcast band. Such an antenna should be at least thirty feet above the ground. By reason of the size of the collector (antenna) the signal strength it picks up is rather large and compensate for small deficiencies between the antenna and the receiver which could not be tolerated with a collector of the smaller size. Therefore, the impedance matching transformer at the antenna is eliminated for both mechanical and financial reasons. A low impedance transmission line is used on both systems between the antenna and the newly developed receiver impedance matching transformer (B) which is connected directly between the lower end of the transmission line and the antenna and ground posts of the receiver itself.

The impedance of the transmission line is approximately 70 ohms and the input (Continued on page 435)



# THOR "RGH-5" Receiver

By ROBERT G. HERZOG, B.S., E.E.,\* and LOUIS KRANZ\*\*

● THE characteristic simplicity of the model RGH-4 is embodied in the RGH-5 with a novel panel arrangement. This simplicity, its low cost, and its remarkable performance on all bands, including the broadcast band, account for its popularity among beginners as well as experimenters in the short-wave field. The plug-in coils are placed in windows in the panel, thus facilitating the changing from one band to another.

The authors in presenting this handsome panel niche claim both efficiency and convenience. The niche is made of metal and is formed to make a shield for the coil that it houses.

Although no hand capacity effects are evident on any of the bands, doors may be made to fit over the opening in the niches.

The circuit is of the regenerative type with three circuit coils in the tuned R.F. and detector stages. A single stage using 2A5's in parallel is sufficient to bring in even the European stations on the loud-speaker.

The detector plate choke is a shielded high-impedance type, capable of carrying at least 3 M.A. without saturation.

\* Chief Engineer, Thor Radio Co.  
\*\* Thor Radio Co.

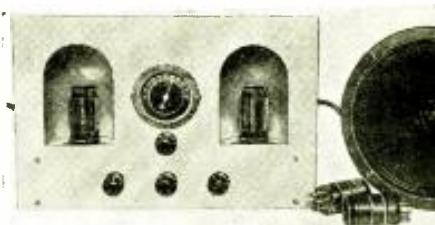

Photo, right, shows the extremely neat appearance of the new "RGH-5". The set tunes very smoothly. (No. 217.)

In wiring the set all the filament, screen, and B plus leads are run around the edges of the chassis, so as to leave the center clear for the small parts and the more important wires. The radio frequency and detector plate and grid leads are wired from point to point with heavy bus-bar. The leads to the detector and the radio frequency grids should be as short as possible with No. 18 stranded wire.

When the set is completely wired, check carefully, making sure all connections are soldered firmly and that no splashes of solder have lodged where they may do harm. After having checked the wiring, plug in the tubes and coils, connect the antenna and ground, and the A-C line. The set is now ready for tuning. No complicated alignment is necessary, for when wired correctly, the RGH-5 will play immediately.

Tuning is a matter which can only be learned by experience and patience. However, some advice can be given here. When the tubes are fully heated with the bias control of the radio frequency stage turned clockwise as far as it will go, turn the regeneration control until a hissing sound is heard in the speaker; rotate the tuning knob very slowly until a slight squeal is heard in the speaker. Concentrate on this squeal, rotating very slightly backwards and forwards until some signal is distinguishable, rearing somewhat if necessary on the regeneration and bias controls. When a signal is heard it can be brought out clearly by means of the antenna compensating condenser.

Although the doublet antenna is almost a necessity for short-wave reception, good results are obtainable on an ordinary antenna. In this case the lower end of the antenna winding is grounded and a small (30-70 mmf.) variable trimmer is connected in series with the antenna.

Results depend only upon the skill with which the novice wires and tunes the receiver. Verifications have been received, already by "fans," from all parts of the world, including New Zealand and Australia—all on the loudspeaker.

(Continued on page 433)

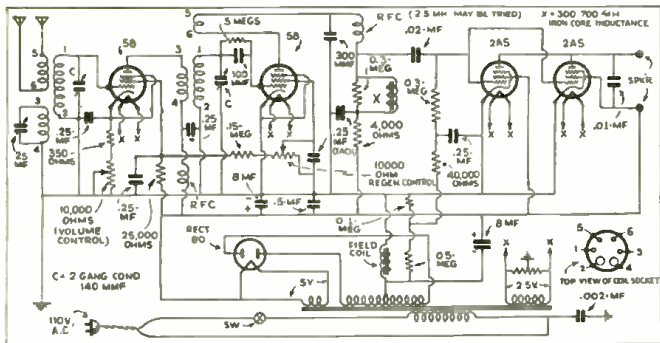

Hook-up used in building the "RGH-5" receiver, which can be had in "kit" form.



New battery-type table set. (No. 218.)

## New Battery All-Wave Sets

● HERE is a very complete all-wave, battery-operated superheterodyne receiver of modern design. It uses seven tubes. A 1C6 is used as the first detector and high frequency oscillator. Two type 34 tubes are used in the two-stage I.F. amplifier. Automatic volume control is effected by the use of a type 30 tube. This tube also functions as the second detector. A screen grid type 32 tube is used as the first audio amplifier and a type 30 follows it and is used as a driver for the 19 class B output power amplifier. This is one of the most modern battery-operated, all-wave superheterodynes on the market.

Short wave fans who are not equipped with facilities for operating an electric set should find this a solution to our problems.

This set should be ideal for summer camps and for use on yachts and other places where electric service circuits do not run. A single knob is used to change from short waves to long waves. The tuning range is from 18,000 kc. to 5,400 kc. for the short-wave band and 1,720 to 540 kc. for the regular broadcast band.

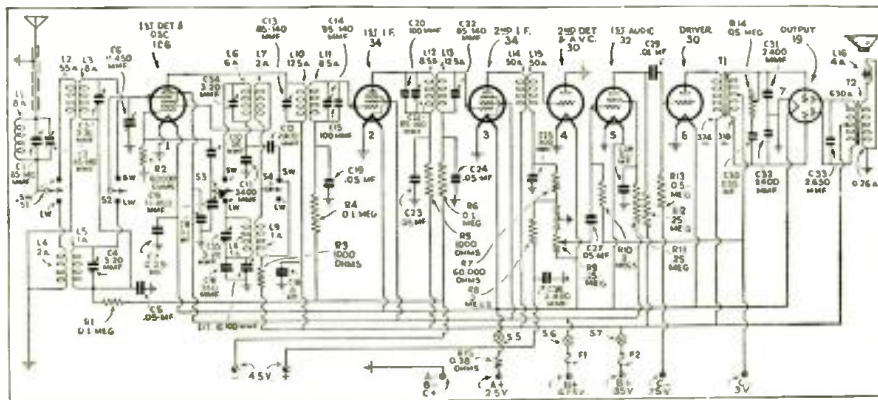
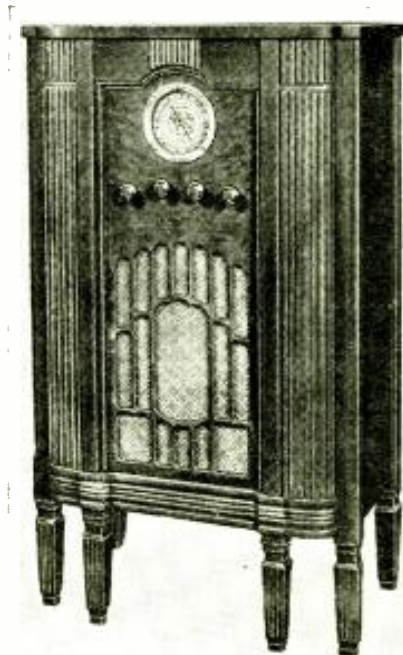

Diagram of the new 7-tube all-wave battery receiver.



Console model of the new battery-type "short" and "broadcast" wave receiver.



# New Hammarlund Coils and Midget Condensers

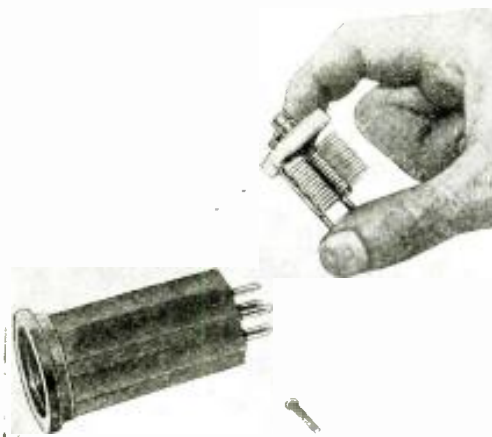

New Hammarlund fluted coil form, and, held between the fingers, the new Midget condenser. (No. 219.)

● TWO interesting items recently developed by the famous house of Hammarlund are a very small "midget" variable condenser and a new type plug-in coil form, bare or wound. The coil forms are made of a new material called XI-53 and this is said to have extremely low losses. By refer-

ring to the photograph we find that the side of the form is fluted, in order to allow considerable air-space in the coil winding. They are made in 4 and 6 prong types and have a handy grip at the top. Inside this grip or flange, is a slight recess which accommodates a circular card on which can be written the wavelength which the coil covers, a fine feature. Ready-wound coils are also available. These are in sets of four, covering a range from 17 to 270 meters, both two- and three-winding coils being available to the experimenter. The secondaries of the 17 to 41 and the 33 to 45 meter coils are wound with heavy silver-plated wire to ensure a minimum of losses. The secondaries of the coils covering the remainder of the tuning range are wound with heavy gauge copper wire. Broadcast coils are also available and are "bank-wound" with Litz (stranded wire). The midget padding condenser developed by Hammarlund will undoubtedly find many important as well as new uses among short-wave fans. They are available in four sizes, namely 25, 50, 75 and 100 mmf. capacities. The over all dimensions of the 100 mmf. condenser are 1 1/2" x 3/8" x 1 1/2". The soldered brass plates have a spacing of .015 inch. The capacity per air-gap is 4 mmf. The drawing clearly shows how this padding condenser can be mounted inside the coil form on the special threaded ledge provided in all coil forms. This is a handy arrangement

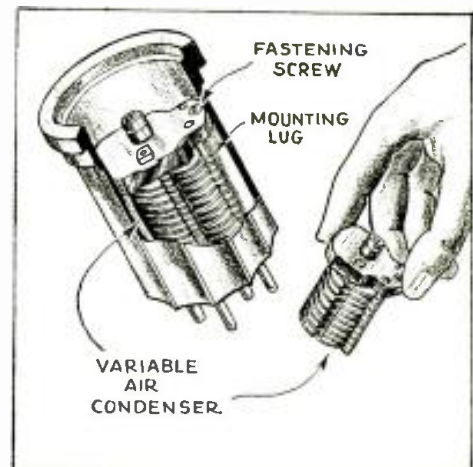

Sectional view of the new Hammarlund fluted coil form, showing how their new Midget Condenser mounts inside the form.

and can be used for padding in band-spread circuits or for fixed tuned circuits. Isolantite insulation is used in this midget condenser which is of extremely low-loss construction.

## Latest NOISE-REDUCING Antennas

### Doublet Uses New Insulators

● SPECIAL antennas seem to be the rage and the short-wave "fad" is now offered a great variety of antenna equipment.

### "Parallel" Feed Doublet

● IN developing the A-K type "D" doublet antenna kit, which is a simple doublet with a parallel transmission line, many comparative tests were made with practically every known type of receiving antenna in order to determine its superior advantages. All results showed a greater signal pick-up over the short-wave range and the suppression of local electrical interference. The kit may be used with any radio set provided with double antenna connections. To permit the use of the doublet antenna with all-wave and short-wave receivers equipped with a regular single antenna connection, the company has developed a special transformer. The transformer is provided with a change-over switch allowing the doublet antenna to be used as a regular single antenna.

### New Noiseless All-Wave Antenna

● A SINGLE antenna with automatic frequency selector and impedance matching switch whereby ideal broadcast or ideal

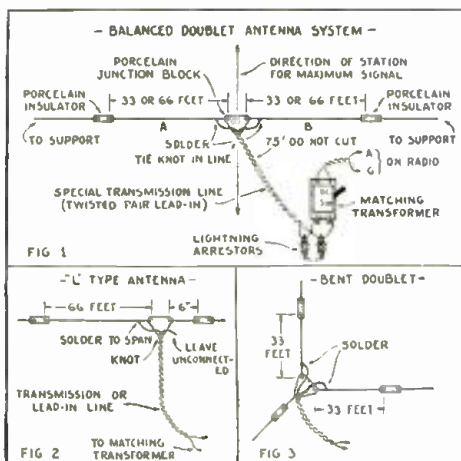

Diagrams, above, show arrangement of the new "noise reduction" antenna system of the doublet type, designed by Porcelain Products, Inc. (No. 220.)

Above, we have three diagrams showing the construction of antennas of different types using a newly developed antenna kit. In Fig. 1, the top diagram, we have the conventional doublet with the twisted pair lead-in of special design. This connects to the center of the antenna and feeds through the matching transformer to the antenna and ground posts of the radio receiver. On this transformer we have a switch which changes the antenna system for either short-wave or broadcast band reception. The L-type antenna shown in Fig. 2 is a modification of the conventional Zeppelin type antenna where two wires feed the end of a horizontal antenna. Only one wire, of course, is left unconnected and in this way effective transmission of energy from the antenna to the set is accomplished, together with the "noise-reduction" qualities of the special lead-in cable. In Fig. 3, we have the same arrangement as shown in Fig. 1; however, the doublet is bent.

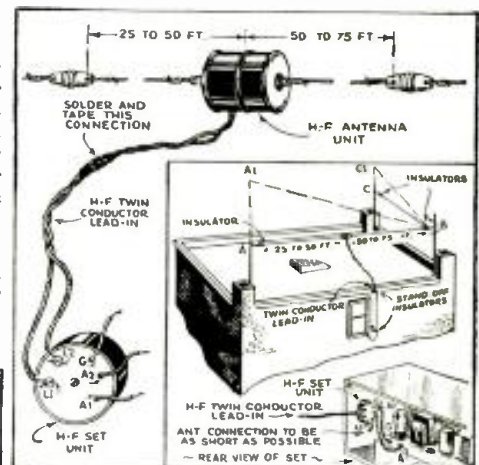

The Technical Appliance Corp. has brought out an efficient all-wave antenna. (No. 222.)

short-wave antenna circuit is provided for intercepted signals, with a positive minimum of background noise, is announced by the Technical Appliance Corporation. The arrangement is available in complete kit form including wire and insulators, or as individual antenna and receiver units.

This noiseless all-wave antenna system is intended primarily for all-wave receivers. It provides the efficiency heretofore attained only through the use of separate broadcast and short-wave aerials, with the added feature of minimum background noise.

Two units comprise the heart of the system. The antenna unit, a compact aluminum-encased device with screw binding posts taking the ends of the aerial wire, is inserted at or near the center of a single-wire aerial. The unit automatically routes signals through the most desirable combination of aerial and downlead. The companion set unit mounted near the receiver, is provided with a switch for impedance selection to obtain the most effective coupling between receiver and downlead.

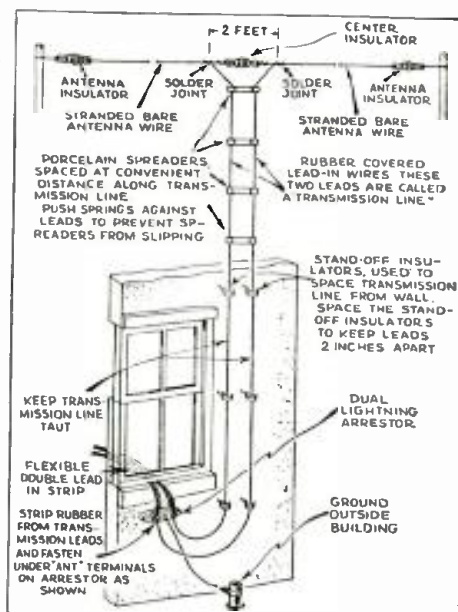
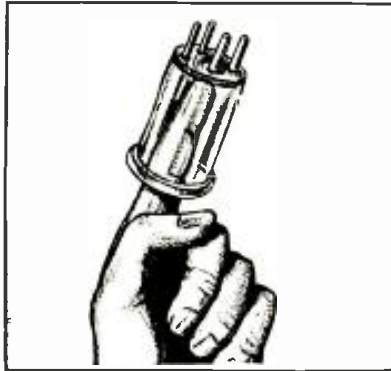

Diagram showing A-K type "D" Doublet Antenna. (No. 221.)

# New Short-Wave Apparatus of Interest

## NEW VICTRON TRANSPARENT COIL FORM



You can see your finger through the wall of the new Victron coil form, the newest addition to the well-known Na-Ald family of short-wave coils and coil forms. This insulating material shows extremely low high-frequency losses. (No. 223.)

## NEW VOLUME CONTROL

● THIS new volume control embodies a noticeable improvement in the principle of applying a perfected graphite resistance element to a smooth surface, over which the contact arm may slide with a minimum of noise and ensuring a smooth, stable graduation of resistance. After the resistance element is applied to the mounting it is baked at very high temperatures. This provides a very solid and rigid anchorage for the resistance element itself and eliminates warping. The mounting block consists of a moulded bakelite ring of sufficient dimensions to form a really solid base. This



Appearance of the newest Electrad product—an ultra smooth working potentiometer with special resistance unit at right. (No. 224.)

control has a full 300 degree rotation, providing a very smooth and long travel of the contact arm and longer life due to the greater amount of contact surface and reduced friction.

## PIONEER DE LUXE ALL-WAVE RECEIVER



One of the newest De Luxe All-Wave Receivers—the "Pioneer".

● THIS modern all-wave receiver covers a range from 11 to 570 meters (29,000 to 530 kc.). It has a four-position selector switch controlled by a single knob. The tube line-up consists of a 58 tuned R.F. amplifier ahead of the first detector, a 2A7 first detector and an electron-coupled oscillator. Three type 58's are used in the intermediate amplifier circuits having 8 tuned circuits, a Wunderlich full-wave rectifier, second detector and automatic volume control tube, a 58 audio frequency oscillator for CW code reception. The first stage of audio uses a 56 and 2V6 power output tubes from the final audio amplifier. A 5Z3 is used for the rectifier and another 5Z3 is used for the speaker field. It is housed in a handsome metal cabinet with a large vernier dial of the airplane type, calibrated for the various ranges which this set covers. The intermediate frequency is 465 kc. and makes use of very high gain I.F. transformers. Extreme selectivity is obtained with the eight tuned circuits in the I.F. amplifier. Provisions are made for phonograph pickup and also for headphone operation.

## ALL-WAVE LINE NOISE FILTER



Newest "All-Wave" Line Noise Filter, built in compact case. (No. 226.)

● KEEPING line noises out of present-day all-wave reception is the function of the new TACO H-F All-Wave Line Filter, just announced by the Technical Appliance Corp.

Housed in an attractive brown metal case with receptacle, ground binding post, attachment cord and non-breakable rubber plug, the all-wave line filter comprises separate filter circuits for broadcast and short-wave bands. The circuits have been worked out over a considerable period by Amy, Aceves & King, Inc., well-known engineers specializing in antenna problems and radio noise elimination. The present device is made under license from them. Filtering is thorough in both broadcast and short-wave bands. Only pure, noiseless AC or DC

(device can be used on either supply) reaches set. Device handles up to 250 watts. The installation is nothing more than plugging usual set plug in receptacle of filter, inserting filter plug in nearest electric outlet, and connecting binding post to convenient ground, grounded chassis or ground binding post of set. If preferred, filter may be inserted between any electric appliance causing line noises, and its power supply, thus combating interference at source.

## NEW "LIGHTNING GRIP" TEST PROD.

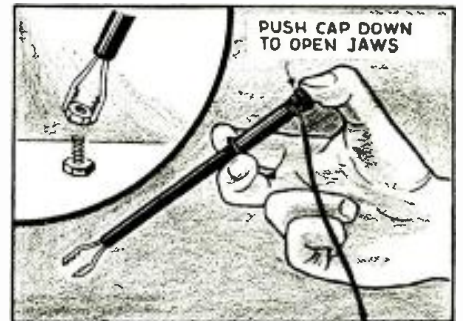

New one-hand "Triple Threat" test prod for connecting test wire to any part of set quickly. (No. 222.)

● A NEW type of test prod has recently been developed, the drawing of which clearly illustrates its construction and immediately suggests that this will be a very handy instrument to have around the "test-bench" or in the "tool-kit". It can be used for various purposes such as getting into those out-of-the-way places in a radio set, grasping wires, screws, etc. Two of them are furnished in the kit, one red and the other black. In making tests, one of them can be clipped fast to the chassis or some part of the wiring to be tested, and the other contacts made with the remaining "prod". The handle is of insulating material and there is no danger of shock. The drawing clearly shows how the snapper is grasped so as to be operable with one hand.

## NEW FRENCH HAND-SET FOR "HAM" TRANS-CEIVERS

● NEWEST product from the laboratory of the Universal Microphone Co., is a combination earphone and microphone which is mounted similar to French phone hand-sets. It has been designed for five-meter transmitters and also the new five-meter transceivers. Since such equipment is necessarily portable, the new combination is extremely lightweight and compact and weighs but nine ounces. The new product consists of a high output microphone in conjunction with 2,000 ohm lightweight receiver. There is a five-foot cord terminal in three-phone tip terminals which gives microphone and earphone connection with one common to both. The handle is rubber covered.



Appearance of the new "Universal" French hand-set, comprising special mike and high resistance, light-weight receiver. (No. 225.)

## VK2METO BROADCAST STATE PROGRAMS TO U. S. A.

● THE EDITORS have just been advised by the famous Australian short-wave broadcasting station, VK2ME, that a portion of their programs is to be dedicated to each state in the U. S. A. These programs are to be broadcast to the respective states in alphabetical order and the tendered program will be radiated at the "peak" period for the particular state's reception. Special announcements via short waves from the station, VK2ME should be listened for, during which time the exact time of the "state" program will be given.



# SHORT WAVE STATIONS OF THE WORLD

## Complete List of Broadcast, Police and Television Stations

We present herewith a revised list of the short-wave broadcasting, experimental and commercial radiophone stations of the world. This is arranged by frequency, but the wavelength figures are also given for the benefit of readers who are more accustomed to working with "meters."

All the stations in this list use telephone transmission of one kind or another and can therefore be identified by the average listener.

other and can therefore be identified by the average listener.

Herewith is also presented a very fine list of police as well as television stations. Note: Stations marked with a star (★) are the most active and easily heard stations and transmit at fairly regular times.

Please write to us about any new stations or other important data that

you learn through announcements over the air or correspondence with the stations themselves. A post card will be sufficient. We will safely return to you any verifications that you send in to us. Communications of this kind are a big help.

Stations are classified as follows: C—Commercial phone. B—Broadcast service. X—Experimental transmissions.

### Around-the-Clock Listening Guide

Although short wave reception is notorious for its irregularity and seeming inconsistency (wherein lies its greatest appeal to the sporting listener), it is a good idea to follow a general schedule as far as wavelength in relation to the time of the day is concerned. The observance of

a few simple rules will save the short wave fan a lot of otherwise wasted time.

From daybreak to late afternoon, and particularly during bright daylight, listen between 13 and 33 meters (21540 to 9000 kc.).

To the east of the listener, from about 1 P.M.-

6 P.M., the 22-35 meter will be found very productive. To the west of the listener this same band is best from about 9 P.M. until shortly after daybreak. After dark, results above 35 meters are usually much better than during daylight. These general rules hold for any location.

## Short-Wave Broadcasting, Experimental and Commercial Radiophone Stations

21540 kc. <b>W8XK</b> -B- 13.93 meters WESTINGHOUSE ELECTRIC PITTSBURGH, PA. 7 a. m.-2 p. m.; relays KDKA	19220 kc. <b>WKF</b> -C- 15.60 meters LAWRENCEVILLE, N. J. Calls England, daytime	18040 kc. <b>GAB</b> -C- 16.63 meters RUGBY, ENGLAND Calls Canada, morn. & early aftn.	16270 kc. <b>WOG</b> -C- 18.44 meters OCEAN GATE, N. J. Calls England. morning and early afternoon	15210 kc. ★ <b>W8XK</b> -B- 19.72 meters WESTINGHOUSE ELECTRIC & MFG. CO. PITTSBURGH, PA. 10 a. m.-4:15 p. m. Relays KDKA
21420 kc. <b>WKK</b> -C- 14.01 meters A. T. & T. CO. LAWRENCEVILLE, N. J. Calls Argentina, Brazil and Peru, daytime	19160 kc. <b>GAP</b> -C- 15.66 meters RUGBY, ENGLAND Calls Australia, early a. m.	17810 kc. <b>PCV</b> -C- 16.84 meters KOOTWIJK, HOLLAND Calls Java, 6-9 a. m.	16233 kc. <b>FZR3</b> -C- 18.48 meters SAIGON, INDO-CHINA Calls Paris and Pacific Isles	15200 kc. ★ <b>DJB</b> -B- 19.73 meters GERMAN S-W STATION Broadcasting House, Berlin, Ger. 12:15-2 a. m., 8-11:30 a. m. Also 4-5:30 a. m. on Sundays
21060 kc. <b>WKA</b> -C- 14.25 meters LAWRENCEVILLE, N. J. Calls England noon	18970 kc. <b>GAQ</b> -C- 15.81 meters RUGBY, ENGLAND Calls S. Africa, mornings	17790 kc. <b>GSG</b> -B- 16.86 meters BRITISH BROAD. CORP. DAVENTRY, ENGLAND See "When to Listen in" Column	15880 kc. <b>FTK</b> -C- 18.90 meters ST. ASSISE, FRANCE Phones Saigon, morning	15140 kc. ★ <b>GSF</b> -B- 19.82 meters BRITISH BROAD. CORP. DAVENTRY, ENGLAND See "When to Listen in" Column
21020 kc. <b>LSN6</b> -C- 14.27 meters HURLINGHAM, ARG. Calls N. Y. C. 8 a. m.-5 p. m.	18830 kc. <b>PLE</b> -C- 15.93 meters BANDOENG, JAVA Calls Holland, early a. m.	17780 kc. ★ <b>W3XAL</b> -B- 16.87 meters NATIONAL BROAD. CO. BOUND BROOK, N. J. Relays WJZ. 10 a. m.-4 p. m. every day	15810 kc. <b>LSL</b> -C- 18.98 meters HURLINGHAM, ARGENTINA Calls Brazil and Europe, daytime	15120 kc. <b>HVJ</b> -B- 19.83 meters VATICAN CITY ROME, ITALY 5:00 to 5:15 a. m., except Sunday. Also Sat. 10-10:30 a.m.
20700 kc. <b>LSY</b> -C- 14.49 meters MONTE GRANDE, ARGENTINA Tests irregularly	18680 kc. <b>GAX</b> -X- 16.06 meters RUGBY, ENGLAND	17760 kc. <b>DJE</b> -B- 16.89 meters GERMAN S-W STATION Broadcasting House, BERLIN Irregular 8 a. m.-2 p. m.	15760 kc. <b>JYT</b> -X- 19.04 meters KEMIKWA-CHO, CHIBAKEN, JAPAN Irregular in late afternoon and early morning.	15055 kc. <b>WNC</b> -C- 19.92 meters HIALEAH, FLORIDA Calls Central America, daytime
20380 kc. <b>GAA</b> -C- 14.72 meters RUGBY, ENGLAND Calls Argentina, Brazil, mornings	18620 kc. <b>GAU</b> -C- 16.11 meters RUGBY, ENGLAND Calls N. Y., daytime	17760 kc. <b>IAC</b> -C- 16.89 meters PIZA, ITALY Calls ships, 6:30-7:30 a. m.	15410 kc. <b>HC1FG</b> -B- 19.47 meters RIOBAMBA, ECUADOR 4:30-6 p. m. Sun.	14980 kc. <b>KAY</b> -C- 20.03 meters MANILA, P. I. Phones Pacific Isles
19900 kc. <b>LSG</b> -C- 15.08 meters MONTE GRANDE, ARGENTINA Tests irregularly, daytime	18345 kc. <b>FZS</b> -C- 16.35 meters SAIGON, INDO-CHINA Phones Paris, early morning	17310 kc. <b>W3XL</b> -X- 17.33 meters NATIONAL BROAD. CO. BOUND BROOK, N. J. Relays WJZ irregularly.	15330 kc. ★ <b>W2XAD</b> -B- 19.56 meters GENERAL ELECTRIC CO. SCHENECTADY, N. Y. Relays WGY daily, 2:30-3:30 p.m.	14590 kc. <b>WMN</b> -C- 20.56 meters LAWRENCEVILLE, N. J. Phones England morning and afternoon
19820 kc. <b>WKN</b> -C- 15.14 meters LAWRENCEVILLE, N. J. Calls England, daytime	18340 kc. <b>WLA</b> -C- 16.36 meters LAWRENCEVILLE, N. J. Calls England, daytime	17120 kc. <b>WOO</b> -C- 17.52 meters A. T. & T. CO., OCEAN GATE, N. J. Calls ships	15300 kc. <b>CP7</b> -B- 19.6 meters LA PAZ, BOLIVIA	14500 kc. <b>LSM2</b> -C- 20.69 meters HURLINGHAM, ARGENTINA Calls U. S., evening
19650 kc. <b>LSN5</b> -C- 15.27 meters HURLINGHAM, ARGENTINA Calls Europe daytime	18310 kc. <b>GAS</b> -C- 16.38 meters RUGBY, ENGLAND Calls N. Y., daytime	17120 kc. <b>WOY</b> -C- 17.52 meters LAWRENCEVILLE, N. J.	15270 kc. ★ <b>W2XE</b> -B- 19.65 meters ATLANTIC BROADCASTING CORP. 485 Madison Av., N.Y.C. Relays WABC daily, 11 a. m.- 1 p. m.	14470 kc. <b>WMF</b> -C- 20.73 meters LAWRENCEVILLE, N. J. Phones England morning and afternoon
19600 kc. <b>LSF</b> -C- 15.31 meters MONTE GRANDE, ARGENTINA Tests irregularly, daytime	18250 kc. <b>FTO</b> -C- 16.43 meters ST. ASSISE, FRANCE Calls S. America, daytime	17080 kc. <b>GBC</b> -C- 17.56 RUGBY, ENGLAND Calls ships	15250 kc. <b>W1XAL</b> -B- 19.67 meters BOSTON, MASS. Irregular, in morning	14440 kc. <b>GBW</b> -C- 20.78 meters RUGBY, ENGLAND Calls U.S.A., afternoon
19380 kc. <b>WOP</b> -C- 15.48 meters OCEAN GATE, N. J. Calls Peru, daytime	18200 kc. <b>GAW</b> -C- 16.48 meters RUGBY, ENGLAND Calls N. Y., daytime	16270 kc. <b>WLK</b> -C- 18.44 meters LAWRENCEVILLE, N. J. Phones Arg., Braz., Peru, daytime	15243 kc. <b>FYA</b> -B- 19.68 meters "RADIO COLONIAL" PARIS, FRANCE Service de la Radiodiffusion, 103 Rue de Grenelle, Paris 7:30-11 a. m.	13990 kc. <b>GBA</b> -C- 21.44 meters RUGBY, ENGLAND Calls Buenos Aires, late afternoon.
19355 kc. <b>FTM</b> -C- 15.50 meters ST. ASSISE, FRANCE Calls Argentine, mornings	18135 kc. <b>PMC</b> -C- 16.54 meters BANDOENG, JAVA Phones Holland, early a. m.			
19355 kc. <b>FTM</b> -C- 15.50 meters ST. ASSISE, FRANCE Calls Argentine, mornings	18115 kc. <b>LSY3</b> -C- 16.55 meters MONTE GRANDE, ARGENTINA Tests irregularly			

(Time given is Eastern Standard Time)

<p><b>13610 kc. JYK</b> -C- 22.04 meters KEMAKAWA-CHO, CHIBA-KEN, JAPAN Phones California till 11 p. m.</p>	<p><b>11790 kc. W1XAL</b> -B- 25.45 meters BOSTON, MASS. Irregularly in the evening</p>	<p><b>10330 kc. ORK</b> -C- 29.04 meters RUYSELEDE, BELGIUM Broadcasts 1:45-3:15 p. m.</p>	<p><b>9590 kc. *VK2ME</b> -B- 31.28 meters AMALGAMATED WIRELESS, LTD., 47 YORK ST. SYDNEY, AUSTRALIA See "When to Listen in" Column</p>	<p><b>9020 kc. GCS</b> -C- 32.26 meters RUGBY, ENGLAND Calls N.Y.C., evenings</p>
<p><b>13585 kc. GBB</b> -C- 22.08 meters RUGBY, ENGLAND Calls Egypt &amp; Canada, afternoons</p>	<p><b>11760 kc. *DJD</b> -B- 25.51 meters GERMAN S-W STATION BROADCASTING HOUSE, BERLIN 12-4:30 p. m., 5:30-10:30 p. m.</p>	<p><b>10300 kc. LSL2</b> -C- 29.13 meters HURLINGHAM, ARGENTINA Calls Europe, evenings</p>	<p><b>9590 kc. W3XAU</b> -B- 31.28 meters NEWTOWN SQUARE, PA. Relays WCAU 12 noon 7:50 p. m.</p>	<p><b>8920 kc. GCX</b> -X- 33.63 meters RUGBY, ENGLAND</p>
<p><b>13415 kc. GCJ</b> -C- 22.36 meters RUGBY, ENGLAND Calls Japan &amp; China early morning</p>	<p><b>11750 kc. *GSD</b> -B- 25.53 meters BRITISH BROAD. CORP. DAVENTRY, ENGLAND See "When to Listen in" Column</p>	<p><b>10260 kc. PMN</b> -C- 29.24 meters BANDOENG, JAVA Calls Australia 5 a. m.</p>	<p><b>9580 kc. *GSC</b> -B- 31.31 meters BRITISH BROAD. CORP. DAVENTRY, ENGLAND See "When to Listen in" Column</p>	<p><b>8775 kc. PNI</b> -C- 34.19 meters MAKASSER, CELEBES, D. E. I. Phones Java around 4 a. m.</p>
<p><b>13390 kc. WMA</b> -C- 22.40 meters LAWRENCEVILLE, N. J. Phones England morning and afternoon</p>	<p><b>11730 kc. PHI</b> -B- 25.57 meters HUIZEN, HOLLAND Daily exc. Tue. &amp; Wed. 7:30-9:30 or 10:30 a. m.</p>	<p><b>10250 kc. LSK3</b> -C- 29.27 meters HURLINGHAM, ARGENTINA Calls Europe and U. S., afternoon and evening</p>	<p><b>9580 kc. VK3LR</b> -B- 31.31 meters Research Section, Postmaster Gen'ls. Dept., 61 Little Collins St., MELBOURNE, AUSTRALIA 3-8 a. m. except Sun.</p>	<p><b>8760 kc. GCQ</b> -C- 34.25 meters RUGBY, ENGLAND Calls S. Africa, afternoon</p>
<p><b>12840 kc. WOY</b> -C- 23.36 meters LAWRENCEVILLE, N. J.</p>	<p><b>11720 kc. *CJRX</b> -B- 25.6 meters WINNIPEG, CANADA Daily, 8 p. m.-12 m. Sunday, 8-10:30 p. m.</p>	<p><b>10220 kc. PSH</b> -C- 29.35 meters RIO DE JANEIRO, BRAZIL</p>	<p><b>9570 kc. *W1XAZ</b> -B- 31.35 meters WESTINGHOUSE ELECTRIC &amp; MFG. CO. SPRINGFIELD, MASS. Relays WBZ, 7 a. m.-1 a. m.</p>	<p><b>8730 kc. GCI</b> -C- 34.36 meters RUGBY, ENGLAND Calls India, 8 a. m.</p>
<p><b>12840 kc. WOO</b> -C- 23.36 meters OCEAN GATE, N. J. Calls ships</p>	<p><b>11720 kc. *FYA</b> -B- "RADIO COLONIAL" PARIS, FRANCE 6:15-9 p. m. 10 p. m.-12 midnight</p>	<p><b>10055 kc. ZFB</b> -C- 29.84 meters HAMILTON, BERMUDA Phones N. Y. C. daytime</p>	<p><b>9570 kc. *W1XAZ</b> -B- 31.35 meters WESTINGHOUSE ELECTRIC &amp; MFG. CO. SPRINGFIELD, MASS. Relays WBZ, 7 a. m.-1 a. m.</p>	<p><b>8680 kc. GBC</b> -C- 34.56 meters RUGBY, ENGLAND Calls Ships</p>
<p><b>12825 kc. *CNR</b> -B, C- 23.39 meters DIRECTOR GENERAL Telegraph and Telephone Stations, Rabat, Morocco Broadcasts, Sunday, 7:30-9 a. m.</p>	<p><b>11680 kc. KIO</b> -X- 25.68 meters KAHUKU, HAWAII Tests in the evening</p>	<p><b>9950 kc. GCU</b> -C- 30.15 meters RUGBY, ENGLAND Calls N.Y.C., evening</p>	<p><b>9565 kc. VUB</b> -B- 31.36 meters BOMBAY, INDIA 11 a. m.-12:30 p. m., Wed., Sat.</p>	<p><b>8560 kc. WOO</b> -C- 35.05 meters OCEAN GATE, N. J. Calls ships irregular</p>
<p><b>12800 kc. IAC</b> -C- 23.45 meters PIZA, ITALY Calls Italian ships Mornings</p>	<p><b>10770 kc. GBP</b> -C- 27.85 meters RUGBY, ENGLAND Calls Sydney, Austral., early a. m.</p>	<p><b>9890 kc. LSN</b> -C- 30.33 meters HURLINGHAM, ARGENTINA Calls New York, evenings</p>	<p><b>9560 kc. *DJA</b> -B- 31.38 meters GERMAN S-W STATION. BROADCASTING HOUSE, BERLIN 8-11:30 a. m., 5:15-9:15 p. m. also 4-5:30 a. m. Sundays</p>	<p><b>8560 kc. WOY</b> -C- 35.05 meters LAWRENCEVILLE, N. J.</p>
<p><b>12780 kc. GBC</b> -C- 23.47 meters RUGBY, ENGLAND Calls ships</p>	<p><b>10740 kc. JVM</b> -C- 27.93 meters NAZAKI, JAPAN Phones California evenings. Broadcasts 3-7:45 a. m.</p>	<p><b>9870 kc. WON</b> -C- 30.4 meters LAWRENCEVILLE, N. J. Phones England, evening</p>	<p><b>9540 kc. LCL</b> -B- 31.45 meters JELDY, NORWAY, Relays Oslo 10 a. m.-4 p. m.</p>	<p><b>8380 kc. IAC</b> -C- 35.8 meters PIZA, ITALY</p>
<p><b>12290 kc. GBU</b> -C- 24.41 meters RUGBY, ENGLAND Calls N.Y.C., afternoon</p>	<p><b>10675 kc. WNB</b> -C- 28.1 meters LAWRENCEVILLE, N. J. Calls Bermuda, daytime</p>	<p><b>9860 kc. *EAQ</b> -B- 30.43 meters P. O. Box 951 MADRID, SPAIN Daily except Saturday and Sunday, 5:15-7 p. m.; Saturday, 12 N.-2 p. m., 5:15-7:30 p. m.; Sunday, 5:15-7:30 p. m.</p>	<p><b>9530 kc. *W2XAF</b> -B- 31.48 meters GENERAL ELECTRIC CO. SCHENECTADY, N. Y. Relays WGY 7:30-11 p. m. Sundays, 7:30 p. m.-12 m.</p>	<p><b>8214 kc. HCJB</b> -B- 36.5 meters QUITO, ECUADOR 7:14-10:15 p. m. except Monday</p>
<p><b>12150 kc. GBS</b> -C- 24.69 meters RUGBY, ENGLAND Calls N.Y.C., afternoon</p>	<p><b>10660 kc. JVN</b> -C- 28.14 meters NAZAKI, JAPAN Tests 2-7 a. m. relaying JOAK, Tokio</p>	<p><b>9840 kc. JYS</b> -C- 30.49 meters KEMIKAWA-CHO, CHIBA-KEN, JAPAN Irregular, 4-7 a. m.</p>	<p><b>9510 kc. *GSB</b> -B- 31.55 meters BRITISH BROAD. CORP. DAVENTRY, ENGLAND See "When to Listen in" Column</p>	<p><b>8185 kc. PSK</b> -C- 36.65 meters RID DE JANIERO, BRAZIL 7-7:30 p. m. Relays PRA3</p>
<p><b>12000 kc. RNE</b> -B- 25 meters MOSCOW, U. S. S. R. Sat. 10-11 p. m. Sun. 6-7 a. m., 10-11 a. m.</p>	<p><b>10550 kc. WOK</b> -C- 28.44 meters LAWRENCEVILLE, N. J. Phones Arge., Braz., Peru, nights</p>	<p><b>9800 kc. LSE</b> -C- 30.61 meters MONTE GRANDE, ARGENTINA Tests irregularly</p>	<p><b>9510 kc. *VK3ME</b> -B- 31.55 meters AMALGAMATED WIRELESS, Ltd. G. P. O. Box 1272L MELBOURNE, AUSTRALIA Wed.- 5-6:30 a. m.; Saturday, 5:00-7:00 a. m.</p>	<p><b>8036 kc. CNR</b> -B- 37.33 meters RABAT, MOROCCO Sunday, 2:30-5 p. m.</p>
<p><b>11950 kc. KKQ</b> -X- 25.10 meters BOLINAS, CALIF. Tests irregularly, evenings</p>	<p><b>10530 kc. GBX</b> -X- 28.49 meters RUGBY, ENGLAND</p>	<p><b>9790 kc. GCW</b> -C- 30.64 meters RUGBY, ENGLAND Calls N.Y.C., evening</p>	<p><b>9510 kc. YV3RC</b> -B- 31.55 meters CARACAS, VENEZUELA Irregularly</p>	<p><b>7901 kc. LSL</b> -C- 37.97 meters HURLINGHAM, ARGENTINA Calls Brazil, night</p>
<p><b>11880 kc. *FYA</b> -B- 25.25 meters "RADIO COLONIAL" PARIS, FRANCE 11:15 a. m.-2:15 p. m.-3-6 p. m.</p>	<p><b>10520 kc. VLK</b> -C- 28.51 meters SYDNEY, AUSTRALIA Calls Rugby, early a. m.</p>	<p><b>9750 kc. WOF</b> -C- 30.77 meters LAWRENCEVILLE, N. J. Phones England, evening</p>	<p><b>9500 kc. *PRF5</b> -B- 31.58 meters RIO DE JANIERO, BRAZIL Irregular, 5-6:30 p. m.</p>	<p><b>7880 kc. JYR</b> -B- 38.07 meters KEMIKAWA-CHO, CHIBA-KEN, JAPAN 4-7:40 a. m.</p>
<p><b>11870 kc. *W8XK</b> -B- 25.26 meters WESTINGHOUSE ELECTRIC &amp; MFG. CO. PITTSBURGH, PA. 4:20-10:00 p. m. Sat. till 1 a. m. Relays KDKA</p>	<p><b>10430 kc. YBG</b> -C- 28.76 meters MEDAN, SUMATRA, D. E. I. 5:30-6:30 a. m., 7:30-8:30 p. m.</p>	<p><b>9710 kc. GCA</b> -C- 30.89 meters RUGBY, ENGLAND Calls Arge. &amp; Brazil, evenings</p>	<p><b>9415 kc. PLV</b> -C- 31.87 meters BANDOENG, JAVA Phones Holland, 7:40-9:40 a. m.</p>	<p><b>7832 kc. OCN</b> -B- 38.3 meters LIMA, PERU (P. O. Box 853) Irregular in evening</p>
<p><b>11860 kc. *GSE</b> -B- 25.29 meters BRITISH BROAD. CORP. DAVENTRY, ENGLAND See "When to Listen in" Column</p>	<p><b>10420 kc. XGW</b> -C- 28.79 meters SHANGHAI, CHINA Calls Manila and England. 6-9 a. m. and California late evening.</p>	<p><b>9600 kc. CT1AA</b> -B- 31.25 meters LISBON, PORTUGAL Tues. and Friday, 3:30-6 p. m.</p>	<p><b>9450 kc. W2XE</b> -B- 25.36 meters ATLANTIC BROADCASTING CORP., 485 MADISON AVE., N. Y. C. 3-5 p. m. Relays WABC</p>	<p><b>7799 kc. *HBP</b> -B- 38.47 meters LEAGUE OF NATIONS. GENEVA, SWITZERLAND 5:30-6:15 p. m., Saturday</p>
<p><b>11830 kc. *W2XE</b> -B- 25.36 meters ATLANTIC BROADCASTING CORP., 485 MADISON AVE., N. Y. C. 3-5 p. m. Relays WABC</p>	<p><b>10410 kc. PDK</b> -C- 28.80 meters KOOTWIJK, HOLLAND Calls Java 7:30-9:40 a. m.</p>	<p><b>9600 kc. YV5RMO</b> -B- 31.25 meters MARACAIBO, VENEZUELA Irregular</p>	<p><b>9330 kc. CJA2</b> -C- 32.15 meters DRUMMONDVILLE, CANADA Phones England irregularly</p>	<p><b>7740 kc. HJ3ABD</b> -B- 40.54 meters P. O. Box 509 BOGOTA, COLOMBIA Daily 12-2 p. m.; 7-11 p. m. Sunday, 5-9 p. m.</p>
<p><b>11810 kc. I2RO</b> -B- 25.4 meters ROME, ITALY</p>	<p><b>10410 kc. KES</b> -X- 28.80 meters BOLINAS, CALIF. Tests evenings</p>	<p><b>9600 kc. XETE</b> -B- 31.25 meters MEXICO CITY, MEXICO Irregularly, 2 p. m.-2 a. m.</p>	<p><b>9280 kc. GCB</b> -C- 32.33 meters RUGBY, ENGLAND Calls Can. &amp; Egypt, evenings</p>	<p><b>7720 kc. HKE</b> -B- 41.55 meters BOGOTA, COL., S. A. Tue. and Sat. 8-9 p. m.; Mon. &amp; Thurs. 6:30-7 p. m.</p>
	<p><b>10350 kc. *LSX</b> -C- 28.98 meters MONTE GRANDE, ARGENTINA Tests irregularly 8 p. m.-12 midnight</p>	<p><b>9595 kc. *HBL</b> -B- 31.27 meters LEAGUE OF NATIONS GENEVA, SWITZERLAND Saturdays. 5:30-6:15 p. m.</p>	<p><b>9170 kc. WNA</b> -C- 32.72 meters LAWRENCEVILLE, N. J. Phones England, evening</p>	<p><b>7140 kc. HJ4ABB</b> -B- 42.02 meters MANIZALES, COL., S. A. P. O. Box 175 Mon. to Fri. 12:15-1 p. m.; Tues. &amp; Fri. 7:30-10 p. m.; Sun. 2:30-5 p. m.</p>

(Time given is Eastern Standard Time)



<p><b>7000 kc. HJ1ABE</b> -B- 42.86 meters CARTAGENA, COL. P. O. Box 31 Daily 11:15 a. m.-1 p. m.; Sun. 9-11 a. m.; Mon. at 10 p. m.; Wed. 8-10 p. m.</p>	<p><b>6272 kc. HI1A</b> -B- 47.84 meters P. O. BOX 243, SANTIAGO, DOMINICAN REP. 11:40 a. m.-1:40 p. m. 7:40-9:40 p. m.</p>	<p><b>6100 kc. *W9XF</b> -B- 49.18 meters DOWNS GROVE, ILL. Relays WENR, Chicago Daily, except Sat., 4:30-8:00 p. m.; 9:30 p. m.-2 a. m.; Sun., 4:30-7 p. m.; 9 p. m.-2 a. m.</p>	<p><b>6060 kc. W3XAU</b> -B- 49.50 meters NEWTOWN SQUARE, PA. Relays WCAU, Philadelphia 8 p. m.-11 p. m.</p>	<p><b>5853 kc. WOB</b> -C- 51.25 meters LAWRENCEVILLE, N. J. Calls Bermuda, nights</p>
<p><b>6977 kc. EAR110</b> -B- 43 meters MADRID, SPAIN Tues., Sat., 5:30 p. m.</p>	<p><b>6150 kc. *CJRO</b> -B- 48.78 meters WINNIPEG, MAN., CANADA 8 p.m.-12 m.; Sun. 8-10:30 p.m.</p>	<p><b>6095 kc. *VE9GW</b> -B- 49.22 meters BOWMANVILLE, ONTARIO, CANADA Sunday 11:30 a.m.-8 p. m. Monday-Wednesday 2-11 p. m. Thursday 3 p. m.-12 m.; Saturday 7 a. m.-12 m.</p>	<p><b>6050 kc. *GSA</b> -B- 49.59 meters BRITISH BROADCAST. CORP. DAVENTRY, ENGLAND See "When To Listen In" Column</p>	<p><b>5714 kc. HCK</b> -B- 52.5 meters QUITO, ECUADOR, S. A.</p>
<p><b>6905 kc. GDS</b> -C- 43.45 meters RUGBY, ENGLAND Calls N.Y.C., evening</p>	<p><b>6150 kc. *YV3RC</b> -B- 48.78 meters CARACAS, VENEZUELA Generally 4:00-10:00 p. m.</p>	<p><b>6090 kc. VE9BJ</b> -B- 49.26 meters SAINT JOHN, N. B., CAN. 7-8:30 p. m.</p>	<p><b>6040 kc. W1XAL</b> -B- 49.67 meters BOSTON, MASS. Very irregular</p>	<p><b>5660 kc. HJ5ABC</b> -B- 53 meters CALLI, COLOMBIA 11 a. m.-12 m. Tues. and Thurs. 8-10 p. m. Sun. 12 m.-1 p. m.</p>
<p><b>6860 kc. KEL</b> -X- 43.70 meters BOLINAS, CALIF. Tests irregularly</p>	<p><b>6140 kc. *W8XK</b> -B- 48.86 meters WESTINGHOUSE ELECTRIC &amp; MFG. CO. PITTSBURGH, PA. Relays KDKA 4:30 p. m.-1 a. m.</p>	<p><b>6080 kc. CP5</b> -B- 49.34 meters LAPAZ, BOLIVIA 7-10:30 p. m.</p>	<p><b>6025 kc. CQN</b> -B- 49.79 meters MACAO, CHINA Mon., Fri., 7-9 a. m.</p>	<p><b>5077 kc. WCN</b> -C- 59.08 meters LAWRENCEVILLE, N. J. Phones England irregularly</p>
<p><b>6755 kc. WOA</b> -C- 44.41 meters LAWRENCEVILLE, N. J. Phones England, evening</p>	<p><b>6130 kc. ZGE</b> -B- 48.92 meters KUALA LUMPUR, FED. MALAY STATES Sun., Tue. and Fri., 6:40-8:40 a. m.</p>	<p><b>6080 kc. *W9XAA</b> -B- 49.34 meters CHICAGO FEDERATION OF LABOR CHICAGO, ILL. Relays WCFL Sunday 11:30 a. m.-9 p. m. and Tues., Thurs., Sat., 4 p. m.-12 m.</p>	<p><b>6020 kc. *DJC</b> -B- 49.83 meters GERMAN S-W STATION BROADCASTING HOUSE, BERLIN 12 m.-4:30 p. m., 5:30-10:30 p. m.</p>	<p><b>5052 kc. ZFA</b> -C- 59.7 meters HAMILTON, BERMUDA Calls U.S.A., nights</p>
<p><b>6666 kc. *HC2RL</b> -B- 45.00 meters P. O. BOX 759, GUAYAQUIL, ECUADOR, S. A. Sunday, 5:45-7:45 p. m. Tues., 9:15-11:15 p. m.</p>	<p><b>6122 kc. JB</b> -B- 49 meters JOHANNESBURG, SOUTH AFRICA Daily except Sat. and Sun., 11:45 p. m.-12:30 a. m., 4-7 a. m., 9 a. m.-3:30 p. m., Sat., only, 4-7 a. m., 9 a. m.- 4:45 p. m. Sun., only, 11:45 p. m.-12:30 a. m., 8-10:30 a. m. and 12:30- 3 p. m.</p>	<p><b>6072 kc. OER2</b> -B- 49.41 meters VIENNA, AUSTRIA Mon. and Thurs., 9 a. m.-1 p. m., 2-3:30 p. m.</p>	<p><b>6020 kc. XEBT</b> -B- 49.83 meters MEXICO CITY, MEX. P. O. Box 79-44 7 p. m.-1 a. m.</p>	<p><b>4975 kc. GBC</b> -C- 60.30 meters RUGBY, ENGLAND Calls Ships, late at night</p>
<p><b>6650 kc. IAC</b> -C- 45.1 meters PIZA, ITALY Calls ships, evenings</p>	<p><b>6120 kc. *W2XE</b> -B- 49.02 meters ATLANTIC BROADCASTING CORP. 485 MADISON AVE., N. Y. C. Relays WABC, 6-11 p. m.</p>	<p><b>6070 kc. *YV5RMO</b> -B- 49.42 meters MARACAIBO, VENEZUELA 5:15-9 p. m.</p>	<p><b>6012 kc. ZHI</b> -B- 49.9 meters RADIO SERVICE CO., 20 ORCHARD RD., SINGAPORE, MALAYA Mon., Wed., Thurs., 5:40-8:10 a. m.; Sat., 12:10-1:10 a. m., 10:40 p. m.-1:10 a. m. (Sunday)</p>	<p><b>4820 kc. GDW</b> -C- 62.24 meters RUGBY, ENGLAND Calls N.Y.C., late at night</p>
<p><b>6620 kc. PRADO</b> -B- 45.30 meters RIOBAMBA, ECUADOR Thur. 9-11:30 p. m.</p>	<p><b>6110 kc. *VE9HX</b> -B- 49.10 meters HALIFAX, NOVA SCOTIA 9:30 a. m.-1 p. m.; 6-12 p. m.</p>	<p><b>6070 kc. VE9CS</b> -B- 49.42 meters VANCOUVER, B. C., CANADA Fri., 12:30-1:45 a. m.; Sun., 12 noon-12 midnight</p>	<p><b>6000 kc. EAJ25</b> -B- 50 meters BARCELONA RADIO CLUB, BARCELONA, SPAIN 3:30-4:30 p. m., Saturday</p>	<p><b>4752 kc. WOO</b> -C- 63.1 meters OCEAN GATE, N. J. Calls ships irregularly</p>
<p><b>6611 kc. RW72</b> -B- 45.38 meters MOSCOW, U. S. S. R. 1-6 p. m.</p>	<p><b>6110 kc. *W3XL</b> -X- 46.70 meters NATIONAL BROADCASTING CO. BOUND BROOK, N. J. Tests irregularly.</p>	<p><b>6065 kc. HIX</b> -B- 49.46 meters SANTO DOMINGO, DOMINICAN REPUBLIC Tues. and Fri., 8-10 p. m.; Sun., 7:45-10:40 a. m., 3-5 p. m. Sat., 10:40-11:40 p. m.</p>	<p><b>6000 kc. RW59</b> -B- 50 meters MOSCOW, U. S. S. R. 4-6 p. m., daily</p>	<p><b>4752 kc. WOY</b> -C- 63.1 meters LAWRENCEVILLE, N. J.</p>
<p><b>6500 kc. HJ5ABD</b> -B- 46.14 meters MANIZALES, COL. 12-1:30 p. m., 7-10 p. m.</p>	<p><b>6110 kc. VUC</b> -B- 49.1 meters CALCUTTA, INDIA Daily except Sat., 3-5:30 a. m., 9:30 a. m.-noon; Sat., 11:45 a. m.-3 p. m.</p>	<p><b>6060 kc. *W8XAL</b> -B- 49.50 meters CROSLY RADIO CORP. CINCINNATI, OHIO 7 a. m.-8 p. m.; 11 p. m.-1 a. m. Relays WLW</p>	<p><b>5990 kc. YV4RC</b> -B- 50.25 meters CARACAS VENEZUELA 7:30-9:30 p. m.</p>	<p><b>4320 kc. G6RX-GDB</b> -C- 69.44 meters RUGBY, ENGLAND Tests, 8-11 p. m.</p>
<p><b>6447k c. *HJ1ABB</b> -B- 46.53 meters BARRANQUILLA, COL., S. A. P. O. BOX 715, 11:30 a. m.-1 p. m.; 5-10 p. m.</p>	<p><b>6100 kc. HJ1ABD</b> -B- 49.18 meters CARTAGENA, COL. 11:30 a. m.-12:30 p. m.; 7-9 p. m.</p>	<p><b>6060 kc. OXY</b> -B- 49.50 meters SKAMLEBOAEK, DENMARK 1-6:30 p. m.; also 8-9 a. m. Sunday</p>	<p><b>5970 kc. HJ2ABC</b> -B- 50.25 meters CUCUTA, COL. 11 a. m.-12 n.; 6-9 p. m.</p>	<p><b>4273 kc. RW15</b> -B- 70.20 meters KHABAROVSK, SIBERIA, U. S. S. R. Daily, 3-9 a. m.</p>
<p><b>6425 kc. *W3XL</b> -X- 46.70 meters NATIONAL BROADCASTING CO. BOUND BROOK, N. J. Tests irregularly.</p>	<p><b>6100 kc. *W3XAL</b> -B- 49.18 meters NATIONAL BROADCASTING CO. BOUND BROOK, N. J. Relays WJZ Monday, Wednesday, Saturday, 5:30 p. m.-1 a. m.</p>	<p><b>6060 kc. VQ7LO</b> -B- 49.50 meters IMPERIAL AND INTERNA- TIONAL COMMUNICATIONS, LTD. NAIROBI, KENYA, AFRICA Mon., Wed., Fri., 5:45-6:15 a. m., 11 a. m.-2 p. m. Tues., 3-4 a. m., 11 a. m.-2 p. m., Thurs. 8-9 a. m., 11 a. m.- 2 p. m., Sat., 11 a. m.-3 p. m., Sun., 10:50 a. m.-2 p. m.</p>	<p><b>5968 kc. HVJ</b> -B- 50.27 meters VATICAN CITY (ROME) 2-2:15 p. m., daily, Sun., 5-5:30 a. m.</p>	<p><b>4272 kc. WOO</b> -C- 70.22 meters OCEAN GATE, N. J. Calls ships irregularly</p>
<p><b>6316 kc. HIZ</b> -B- 47.5 meters SANTO DOMINGO, DOMINICAN REPUBLIC Daily except Sat. and Sun. 4:40-5:40 p. m.; Sat., 9:40- 11:40 p. m.; Sun., 11:40 a. m.-1:40 p. m.</p>	<p><b>6100 kc. *HJ3ABF</b> -B- 47.81 meters BOGOTA, COLOMBIA P. O. Box 317 12-1:30 p. m.-7-11 p. m. exc. Sunday Wed. and Sat. 6-11 p. m. Tues. and Fri. 6:30-11 p. m.</p>	<p><b>6060 kc. PK1WK</b> -B- 49.5 meters BANDOENG, JAVA Daily, exc. Fri. 4:30-5:30 a. m.</p>	<p><b>5930 kc. HJ4ABE</b> -B- 50.6 meters MEDELLIN, COLOMBIA Mon., 7-11 p. m.; Tues., Thurs., Sat., 6:30-8:00 p. m.; Wed. and Fri., 7:30-11:00 p. m.</p>	<p><b>4272 kc. WOY</b> -C- 70.22 meters LAWRENCEVILLE, N. J.</p>
<p><b>6275 kc. HJ3ABF</b> -B- 47.81 meters BOGOTA, COLOMBIA P. O. Box 317 12-1:30 p. m.-7-11 p. m. exc. Sunday Wed. and Sat. 6-11 p. m. Tues. and Fri. 6:30-11 p. m.</p>	<p><b>6100 kc. *W3XAL</b> -B- 49.18 meters NATIONAL BROADCASTING CO. BOUND BROOK, N. J. Relays WJZ Monday, Wednesday, Saturday, 5:30 p. m.-1 a. m.</p>	<p><b>6060 kc. PK1WK</b> -B- 49.5 meters BANDOENG, JAVA Daily, exc. Fri. 4:30-5:30 a. m.</p>	<p><b>5880 kc. HJ2ABA</b> -B- 51.02 meters TUNJA, COL. 1-2 p. m., 7:30-10 p. m.</p>	<p><b>4107 kc. HCJB</b> -B- 73 meters QUITO, ECUADOR 7:14-10:15 p. m., except Monday</p>

"WHEN TO LISTEN IN" APPEARS ON PAGE 428

## POLICE RADIO ALARM STATIONS

CGZ Vancouver, B. C.	2452 kc.	KGHX Santa Ana, Cal.	2430 kc.	KGPB Minneapolis, Minn.	2430 kc.
CJW St. Johns, N. B.	2416 kc.	KGHY Whittier, Cal.	1712 kc.	KGPC St. Louis, Mo.	1706 kc.
CJZ Verdeen, Que.	2452 kc.	KGHZ Little Rock, Ark	2406 kc.	KGPD San Francisco, Cal.	1674 kc.
KGHG Las Vegas, Nev.	2474 kc.	KGJX Pasadena, Cal.	1712 kc.	KGPE Kansas City, Mo.	2422 kc.
KGHK Palo Alto, Cal.	1674 kc.	KGLX Albuquerque, N. M.	2414 kc.	KGPG Vallejo, Cal.	2422 kc.
KGHM Reno, Nev.	2474 kc.	KGOZ Cedar Rapids, Iowa	2466 kc.	KGPH Oklahoma City, Okla.	2450 kc.
KGHO Des Moines, Iowa	1682 kc.	KGPA Seattle, Wash.	2414 kc.		

# Short Wave Stations of the World

VYR	Montreal, Can.	1712 kc.	WKDU	Cincinnati, Ohio	1706 kc.	WPET	Lexington, Ky.	1706 kc.
VYW	Winnipeg, Man.	2416 kc.	WMDZ	Indianapolis, Ind.	2442 kc.	WPEW	Northampton, Mass.	1666 kc.
WCK	Belle Island, Mich.	2414 kc.	WMJ	Buffalo, N. Y.	2422 kc.	WPFA	Newton, Mass.	1712 kc.
WEY	Boston, Mass.	1558 kc.	WMO	Highland Park, Mich.	2414 kc.	WPFC	Muskegon, Mich.	2442 kc.
KGPI	Omaha, Neb.	2466 kc.	WMP	Framingham, Mass.	1666 kc.	WPFH	Highland Park, Ill.	2430 kc.
KGPI	Beaumont, Tex.	1712 kc.	WPDA	Tulare, Cal.	2414 kc.	WFFE	Reading, Pa.	2442 kc.
KGPK	Sioux City, Iowa	2466 kc.	WPDB	Chicago, Ill.	1712 kc.	WPFJ	Jacksonville, Fla.	2442 kc.
KGPL	Los Angeles, Cal.	1712 kc.	WPDC	Chicago, Ill.	1712 kc.	WPFH	Baltimore, Md.	2414 kc.
KGPM	San Jose, Cal.	1674 kc.	WPDD	Chicago, Ill.	1712 kc.	WPFJ	Columbus, Ga.	2414 kc.
KGPN	Davenport, Iowa	2466 kc.	WPDE	Louisville, Ky.	2442 kc.	WPKF	Hackensack, N. J.	2430 kc.
KGPO	Tulsa, Okla.	2450 kc.	WPDF	Flint, Mich.	2466 kc.	WPFL	Gary, Ind.	2470 kc.
KGPP	Portland, Ore.	2442 kc.	WPDG	Youngstown, Ohio	2458 kc.	WPFM	Birmingham, Ala.	2382 kc.
KGPP	Honolulu, T. H.	2450 kc.	WPDH	Richmond, Ind.	2430 kc.	WPFN	Fairhaven, Mass.	1712 kc.
KGPS	Bakersfield, Cal.	2414 kc.	WPDI	Columbus, Ohio	2430 kc.	WPFO	Knoxville, Tenn.	2474 kc.
KGPW	Salt Lake City, Utah	2406 kc.	WPKD	Milwaukee, Wis.	2450 kc.	WPFJ	Clarksburg, W. Va.	2490 kc.
KGQV	Denver, Colo.	2442 kc.	WPDL	Lansing, Mich.	2442 kc.	WPFQ	Swathmore, Pa.	2474 kc.
KGQY	Baton Rouge, La.	1574 kc.	WPDN	Dayton, Ohio	2430 kc.	WPFJ	Johnson City, Tenn.	2470 kc.
KGQZ	Wichita, Kans.	2450 kc.	WPDN	Auburn, N. Y.	2382 kc.	WPFJ	Asheville, Md.	2458 kc.
KGZA	Fresno, Calif.	2414 kc.	WPDO	Akron, Ohio	2458 kc.	WPFU	Portland, Me.	2422 kc.
KGZB	Houston, Tex.	1712 kc.	WPDJ	Philadelphia, Pa.	2474 kc.	WPFV	Pawtucket, R. I.	2466 kc.
KGZC	Topeka, Kans.	2422 kc.	WPDR	Rochester, N. Y.	2382 kc.	WPFX	Palm Beach, Fla.	2442 kc.
KGZD	San Diego, Cal.	2490 kc.	WPDS	St. Paul, Minn.	2430 kc.	WPFZ	Miami, Fla.	2442 kc.
KGZE	San Antonio, Tex.	2482 kc.	WPDT	Kokomo, Ind.	2490 kc.	WPGA	Bay City, Mich.	2466 kc.
KGZF	Chanute, Kans.	2450 kc.	WPDV	Pittsburgh, Pa.	1712 kc.	WPGH	Port Huron, Mich.	2466 kc.
KGZG	Des Moines, Iowa	2466 kc.	WPDV	Charlotte, N. C.	2458 kc.	WPGI	S. Schenectady, N. Y.	1658 kc.
KGZH	Klamath Falls, Ore.	2382 kc.	WPDW	Washington, D. C.	2422 kc.	WPGJ	Rockford, Ill.	2458 kc.
KGZI	Wichita Falls, Tex.	2458 kc.	WPDY	Detroit, Mich.	2414 kc.	WPGK	Providence, R. I.	1712 kc.
KGZJ	Phoenix, Ariz.	2430 kc.	WPDZ	Atlanta, Ga.	2414 kc.	WPGM	Findlay, Ohio	1682 kc.
KGZL	Shreveport, La.	1712 kc.	WPEA	Fort Wayne, Ind.	2490 kc.	WPGN	Albany, N. Y.	2414 kc.
KGZM	El Paso, Tex.	2414 kc.	WPEB	Syracuse, N. Y.	2382 kc.	WPGO	Portsmouth, Ohio	2430 kc.
KGZN	Tacoma, Wash.	2414 kc.	WPEC	Grand Rapids, Mich.	2442 kc.	WPGP	Utica, N. Y.	2414 kc.
KGZO	Santa Barbara, Cal.	2414 kc.	WPEE	Memphis, Tenn.	2466 kc.	WPGQ	Cranston, R. I.	2166 kc.
KGZP	Coffeyville, Kans.	2450 kc.	WPEF	Arlington, Mass.	1712 kc.	WPGR	Binghamton, N. Y.	2442 kc.
KGZQ	Waco, Tex.	1712 kc.	WPEG	New York, N. Y.	2450 kc.	WPGS	South Bend, Ind.	2490 kc.
KGZR	Salem, Ore.	2442 kc.	WPEH	New York, N. Y.	2450 kc.	WPGT	Huntington, N. Y.	2490 kc.
KGZS	McAlester, Okla.	2458 kc.	WPEI	Somerville, Mass.	1712 kc.	WPGU	Mineola, N. Y.	2490 kc.
KGZT	Santa Cruz, Cal.	1674 kc.	WPEJ	E. Providence, R. I.	1712 kc.	WPGV	Boston, Mass.	1712 kc.
KGZU	Lincoln, Neb.	2490 kc.	WPEK	New Orleans, La.	2430 kc.	WRBH	Cleveland, Ohio	2458 kc.
KGZW	Lubbock, Tex.	2458 kc.	WPEL	New Orleans, La.	2430 kc.	WRDQ	Toledo, Ohio	2474 kc.
KGZX	Albuquerque, N. Mex.	2414 kc.	WPEM	W. Bridgewater, Mass.	1666 kc.	WRDR	Grodo Pt. Village, Mich.	2414 kc.
KSX	Berkeley, Cal.	1658 kc.	WPEP	Woonsocket, R. I.	2466 kc.	WRDS	E. Lansing, Mich.	1666 kc.
KVP	Dallas, Tex.	1712 kc.	WPES	Arlington, Mass.	1712 kc.			
WKDT	Detroit, Mich.	1558 kc.		Saginaw, Mich.	2442 kc.			

## AIRPORT RADIO Stations

**AERONAUTICAL (AIRPORT) FREQUENCIES**

(Red Chain)

3,147.5	3,322.5	5,582.5
3,162.5	5,122.5	5,592.5
3,172.5	5,572.5	5,662.5
3,182.5		

(Blue Chain)

2,906	4,937.5	4,952.5
3,072.5	4,967.5	5,672.5
3,088		5,692.5
2,720	6,510: Day only	
2,732	6,520: Day only	
4,110	6,530: Day only	
	8,015: Day only	

(Brown Chain)

3,127.5	4,917.5	3,005
3,222.5	5,602.5	2,854
3,232.5	5,612.5	5,377.5
3,257.5	5,632.5	
3,447.5		
3,457.5		
3,467.5		
3,485		
2,640	4,740	6,540
2,644		6,550
2,612		6,560
2,636		8,015
3,467.5		

(Green Chain)

2,922	4,122.5	
-------	---------	--

2,946	5,652.5	
2,986		
2,748	6,590	
4,745	6,600	
	(Orange Chain)	
2,870	5,375	8,220
3,082.5	5,405	12,330
	5,692.5	16,440
2,648	6,570	
3,082.5	6,580	
5,375	8,015	
	16,240	

The various transport companies are assigned frequencies for their use and each transport company's network is given a certain code color.

**\$20.00 PRIZE MONTHLY FOR "BEST" 1-TUBE SET**

Or other short-wave set article accepted and published. Send diagram first or set if you prefer. Sets must be sent PREPAID and should be CAREFULLY PACKED in a WOODEN box!

The closing date for each contest is sixty days preceding date of issue (Nov. 1 for the Jan. issue, etc.). In the event of a "tie" an equal prize will be paid to each contestant so tying.

The judges will be the editors of SHORT WAVE CRAFT, and George Shuart and Clifford E. Denton, who will also serve on the examining board. Their findings will be final.

Address your entries to:  
 Editor,  
 SHORT WAVE CRAFT,  
 99-101 Hudson St.,  
 New York City.

## TELEVISION Stations

1600-1700 kc.	176.5-187.5 m.
W2XR—Long Island City, N. Y.	
W8XAN—Jackson, Mich.	
2000-2100 kc.	142.9-150 m.
W9XAO—Chicago, Ill.	
W6XAH—Bakersville, Cal.	
W9XK—Iowa City, Iowa	
2100-2200 kc.	136.4-142.9 m.
W2XBS—New York, N. Y.	
W6XS—Los Angeles, Calif.	
W9XAP—Chicago, Ill.	
W9XAK—Manhattan, Kans.	
2200-2300 kc.	130.4-136.4 m.
W9XAL—Kansas City, Mo.	
2750-2850 kc.	105.3-109.1 m.
W9XG—W. Lafayette, Ind.	
43,000-46,000 kc.	6.52-5.98 m.
48,500-50,300 kc.	6.00-6.20 m.
60,000-80,000 kc.	3.75-5.00 m.
W9XD—Milwaukee, Wis.	
W9XE—Marion, Ind.	
W8XF—Pontiac, Mich.	
W3XAD—Camden, N. J.	
W2XR—Long Island City, N. Y.	
W9XAT—Portable	
W2XF—New York, N. Y.	
W6XAO—Los Angeles, Calif.	
W3XE—Philadelphia, Pa.	
W2XAK—New York, N. Y.	
W10XX—Portable and Mobile	
W8XAN—Jackson, Mich.	
W8XL—Cuyahoga, Heights, Ohio	



# SHORT WAVE LEAGUE



## HONORARY MEMBERS

- Dr. Lee de Forest
- John L. Reinartz
- D. E. Replogle
- Hollis Baird
- E. T. Somerset
- Baron Manfred von Ardenne
- Hugo Gernsback
- Executive Secretary*

## A Good Argument for Modified Code Test on 5 Meters

Editor, SHORT WAVE CRAFT:

Gentlemen:

● THE discussion of code or no code for 5 meter work has been long and voluminous. So far, however, the main reasons advanced have fallen in two general classes. One class seems to say, "I do not know the code and want to use a small transmitter," while the second group seems to say, "I know the code and think everyone should."

The present test requires *ten words per minute code speed*: this seems quite fast to one first learning code, because he seems to get to 6 or 7 words per minute and sticks there for ages. This is an experience common to all and very disheartening. However, in the 160, 80, 40 and 20 meter bands very few ever send that slow. These bands are well populated and a signal in them goes places and does things.

On 5 meters a signal does not go nearly as far but gives quite an amount of pleasure to the owner. If 5 meters was exclusively populated and assigned to phone work, a code test might be readily dispensed with, as it is today in the *broadcast and police* bands, but since this is not so, a knowledge of code is essential, if only to receive a request to change frequency slightly to avoid interference.

However, the code test advocates in their protests say that 5 meter transmission is in the same state at 200 meter work in 1912. Very fine! In 1912 the code test was five words a minute. Then let there be special 5 meter licenses issued for use only in that or higher frequency bands requiring only a 5 words a minute code test. As the 3 letter calls are pretty nearly used up and a 4 letter call is rather bulky for consistent fast code

work, let the 4 or 5 letter calls be assigned to this type of license, thereby readily distinguishing the stations and prevent "bootlegging" into the higher code speed bands.

Yours truly,  
J. CALEB PHIPPS.

### He Wants Action!

Editor, SHORT WAVE CRAFT:

● I WISH to have something to say concerning the 5-meter "Codeless Exam." As it is in any argument, there will always be fellows on both sides of the argument. I am for the "Codeless Exam," below 6 meters and would like to see some official action taken toward putting it over.

Some weeks past I purchased your June issue of SHORT WAVE CRAFT, which started me off in short waves. I have built the "Duo-Amplidyne" receiver with satisfactory results considering all the "static interference" just about in my back-yard; this is in the form of the local street-car line and parallel to that the Interurban line to Waukesha and Burlington, and overhead about 70 feet to 100 feet, eight high tension lines with 4,500 volts in each line making a total of 36,000 volts, in addition to the two electric lines.

Now about the argument. Some day I would like to talk to these amateurs in Muskegon, Elgin, Appleton, and others in my locality here. I believe I could learn the code, but how would the transmitting turn out? Then on the other hand I would enjoy it more to speak with these fellows than sit there and listen to dits and dahs. Fellows who are interested in CW can learn it anyway, if they want to, and no 5-meter fellows will disturb them. I have listened to some CW signals and if they were not QSA I would like to hear one that is, even an amateur station located at Muskegon, Michigan, does a poor job in transmitting every once in a while, while other stations in almost the same band come in better, so I do not believe it to be my receiver. I would like to tell these fellows just what good amateurs they are. Most of these fellows are OK on CW, but when they get to phone transmitting—phew!!!

I suggest a vote from all fellows (including YL's) reading about these arguments to send in their vote either "Pro" or "Con" within two months time on a post-card or Official Voting Blank issued through SHORT WAVE CRAFT to clip and mail. Then you will have the general opinion and I believe



## Short Wave League

At a Directors Meeting held in New York City, New York, in the United States of America, the Short Wave League has elected

**John F. Müller**

a member of this League.

In Witness whereof, this certificate has been officially signed and presented to the above.

*H. Winfield Seaton*  
Club Secretary

This is the handsome certificate that is presented FREE to all members of the SHORT WAVE LEAGUE. The full size is 7¼" x 9½".

See page 445—how to obtain certificate.

it will be in my favor. So let's get this settled!

WM. R. FARR,  
Milwaukee, Wis.

## Get Your Button

The illustration here-with shows the beautiful design of the "Official" Short Wave League button, which is available to everyone who becomes a member of the Short Wave League.

The requirements for joining the League are explained in a booklet, copies of which will be mailed upon request. The button measures ¾ inch in diameter and is inlaid in enamel—3 colors—red, white, and blue.



Please note that you can order your button AT ONCE—SHORT WAVE LEAGUE supplies it at cost, the price, including the mailing, being 35 cents. A solid gold button is furnished for \$2.00 prepaid. Address all communications to SHORT WAVE LEAGUE, 99-101 Hudson St., New York.

### 40 Per Cent Flunk CODE TEST!

● IN A recent report received from the Federal Communications Commission at Washington, D. C., it is interesting to note that there are now 46,390 valid amateur station licenses in existence. Particularly interesting, from the viewpoint of the proponents of the "No Code Test Below 6 Meters" argument, is the fact that of the 3,631 applicants for amateur station licenses during the last fiscal year, forty per cent failed to pass the code test! This test only required the applicant to receive at the low speed of 10 words per minute, and the failure of forty per cent of the applicants to pass the code test, would seem to indicate that it is not the simplest accomplishment in the world to learn the code.

**\$5.00 PRIZE  
NOVEL ANTENNA  
CONDENSER**

This antenna coupling arrangement which I have found to work very well is made from a one inch metal square (thin sheet brass) mounted on an adjustable metal arm, so that it rests about one-eighth of an inch from the grid winding of the plug-in coil.

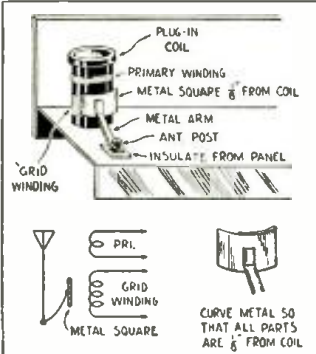

Since the number of turns in the grid windings decrease with the wave-length, this manner of coupling automatically varies accordingly as each of the plug-in coils is inserted. This differs from an equalizing condenser, which has to be changed with each coil.

The exact position for the metal plate in relation to the grid winding of the plug-in coil can best be determined by experiment.—Rolind Mahan.

**MAKING A MIDGET  
CONDENSER**

Remove the rheostat winding and cut two semi-circular pieces of tin, drill a hole in the edge of one and mount it on the insulated burr, then bend it down over the back of the rheostat. Solder the other plate to the arm, and there you are. The plates should be set so that they can come together without touching.—Henry Lambert.

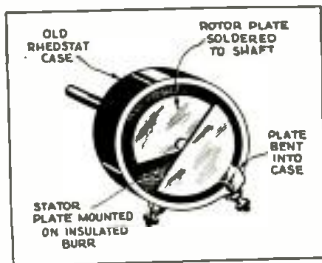

**INSULATION SCRAPER**

Here's a handy tool I use to scrape the insulation from wire, and it does a very good job of it too. Break off the end of an old hack saw blade, about four inches long, and wrap with one layer of tape all but about an inch on the end where the hole is.—Chas. Watts.

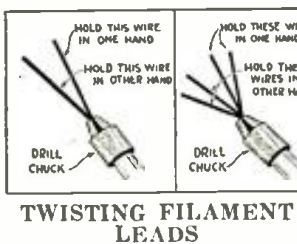
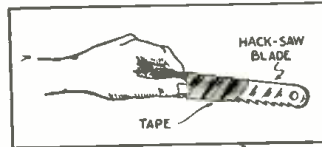

**TWISTING FILAMENT  
LEADS**

An excellent method of making twisted leads is to take two wires, twist them together for about a half an inch or so, and then put them in the chuck of an ordinary hand drill. By having someone turn the drill while you hold the two loose ends, twisted filament leads, tightly wound and neatly made can be easily constructed. This method can be used in making wire cables.—Edward Carroll, W2GUY.

**\$5.00 FOR BEST  
SHORT WAVE KINK**

The Editor will award a five dollar prize each month for the best short-wave kink submitted by our readers. All other kinks accepted and published will be paid for at regular space rates. Look over these "kinks" and they will give you some idea of what the editors are looking for. Send a typewritten or ink description, with sketch, of your favorite short-wave kink to the "Kink" Editor, SHORT WAVE CRAFT.

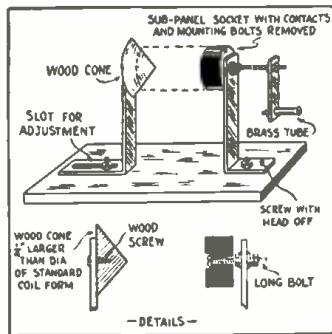

**COIL WINDER**

This coil-winder makes winding four or five prong coils very easy. This coil winder is not hard to build and I am sure it will help some fellows and I think the sketch explains itself. The sockets used are old tube sockets; the four prong socket is a subpanel mount, having four bolts for mounting which are taken out. The other socket is a five prong one, a baseboard mount with the contacts and base taken off. This leaves just a shell with a hole in the center and the five prong holes.—Howard Cookson.

**NEUTRALIZING TOOL**

I finished my short-wave set and found that I needed a neutralizing tool to adjust the compensating condenser in the antenna circuit. I hunted around and found that I didn't have any, so I decided to make one. I found a piece of one-quarter inch copper tubing and a five inch long piece of dowel, which would fit into the copper tubing. I cut off an inch and a half of the tubing and sawed half-inch slots in one end to fit the nut on the condenser. Then I wound thin copper wire around this end and gave it a thin coat of solder to hold the slots in place. I put the dowel in the opposite end, and there was the tool that I wanted.—J. P. Sheridan.

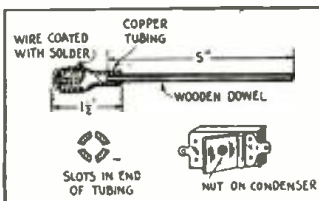

**TRANSMITTER LEAD-IN  
"BOWLS"**

Procure two stand-off insulators and remove the hardware. Drill a hole in the window pane. Procure a long threaded brass or other rod and pass this through the insulators and window glass. Tighten the assembly by putting nuts on end of the shaft as shown.—E. B. Frye.

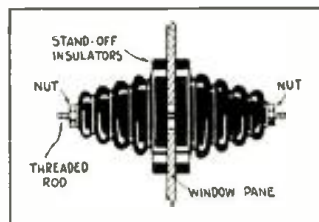

**CHEAP SHIELD CANS**

In making this shield you must first select a can suitable in size and shape to cover the object you wish to shield. Then measure the height of the object and allow one-half inch for clearance. When measuring this height on the can, allow spaces for flaps. Cut out along this line and discard the top, then drill a half inch hole in the side for wires coming out of shield from shielded object. If a tube is being shielded it is necessary to drill a hole in top just over the tube for ventilation; it also serves to see whether the tube is lighted without removing the shield. The shield is fastened to the base-board of the set with screws or bolts. The shield may be painted, and thus improve its appearance.—Robert L. Wood.

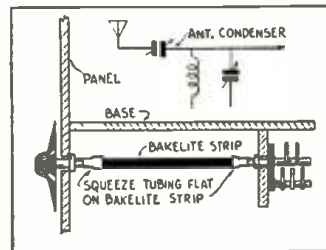
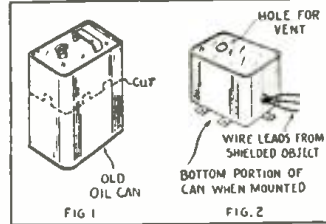

**ANTI-CAPACITY  
CONTROL**

In most short-wave sets using the regular antenna condenser "body capacity" interferes whenever the operator is about to adjust it. I found by installing it at the back of the set and controlling it on the front panel as shown in sketch, that the effect was eliminated. Cut 2 pieces of copper tubing 1/4 by 1/4 long or a piece of tin to the shape required. Slip this tubing or sleeve over the 1/4 inch condenser shaft and solder; next cut a strip of bakelite panel 1/4 wide by the length desired to suit. The other piece of tubing is soldered on the 1/4 inch shaft and a collar and set-screw provided as shown. Squeeze tube flat on the bakelite strip with a pair of pliers at b-b in diagram. Attach control knob and that's that.—Luis A. D'Lenreux.

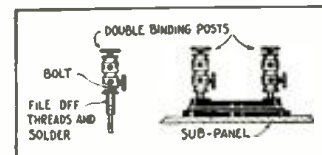

**CONNECTING 2 PAIRS  
PHONES**

A convenient method of connecting two pairs of ear-phones to a set may be improvised by the use of two double-binding-posts, two screws about 1/4 in. long, and two phone cord tips. Thread the screws into the binding posts, remove the threads from the other end, and insert into the phone tip and solder the binding posts to the screw and tip; you then have a simple arrangement for connecting two phones or phone and speaker.—John F. Derr.

**GANGING TOGGLE  
SWITCHES**

It is frequently desirable to gang two or more toggle switches so that they can be operated from one lever or button. The accompanying sketch shows how to do this in a simple and efficient manner. A piece of fiber or bakelite has holes drilled in it at the proper points to come in contact with the knobs on the ends of the

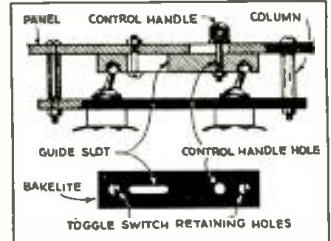

toggle switch levers. A slot in the narrow strip behind the panel permits it to be slid sidewise, with a screw as a "slot guide" as shown.—J. L. Caruth, W5EDB.

**VARIOMETER IMPROVES  
TUNING**

A variometer placed in the antenna will make signals increase in loudness.

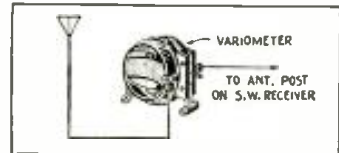

For short-wave "fans" who haven't space for a long antenna, a short antenna works well with this circuit I find.—Wm. Waltham.

**A COMPACT ANTENNA  
FOR 5 METERS**

This antenna has proven very satisfactory for five meters. It does not have to be hung on a tree or rolled up at every transmission—it is a "time-saver". It occupies a minimum of space and has proven very efficient. The antenna consists of a small steel rule of the type that rolls out straight when a button is pressed. This may be purchased for a nominal sum at any hardware or "5 and 10 cent" store. It should be secured against the side of the case with a hole in the case for the button. As a voltage-fed Hertz aerial the length should be eight feet. With four feet and a ground, the Marconi type may be used. The length may be read directly from the rule. A slot in the top of the case allows the rule to rise vertically in the air.—W. Hlome.

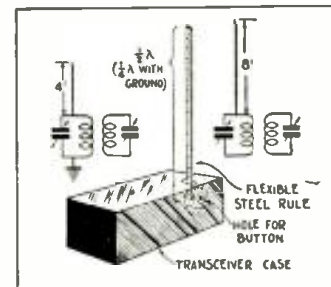

**HANDY COIL RACK**

My coils, too, have a habit of rolling off the table and on the floor, so I stopped this by making a rack of bakelite for them. I cut out a piece of bakelite 7" x 3", then taking the top off an old Grebe spring socket, I used it as a template for locating the holes and spacing them properly. If a socket-top is not handy, one can be made from cardboard easily. Two angles bolted to the bakelite serve as a means of fastening the rack to the side of the table. Hardiness and simplicity are the two main features of this rack.—Wm. Fishback.

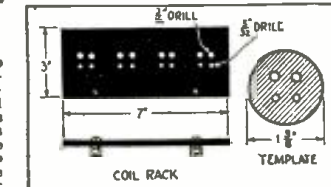



# SHORT WAVE QUESTION BOX

## BROADCAST COIL FOR SHORT-WAVE SET

Paul Sawin, Sheridan, Wyoming.

(Q) Could you supply me with information on how to wind a broadcast coil for my short-wave receiver. My receiver circuit is one using two stages of audio, with a detector and two 01A's in the other two stages. The tuning condensers are one 0-35 mmf. trimmer condenser and one standard receiving type variable condenser from a 3-tube Croy "R.C." receiver.

(A) A broadcast coil for your receiver should have approximately 120 turns of No. 30 enamelled copper wire for the grid coil and 25 turns of the same size wire for the tickler. The spacing between the tickler and grid coil should be approximately  $\frac{1}{4}$  of an inch.

## "ALL-PURPOSE" RECEIVER

E. J. Villwock, Milwaukee, Wis.

(Q) Will you please publish the dia-

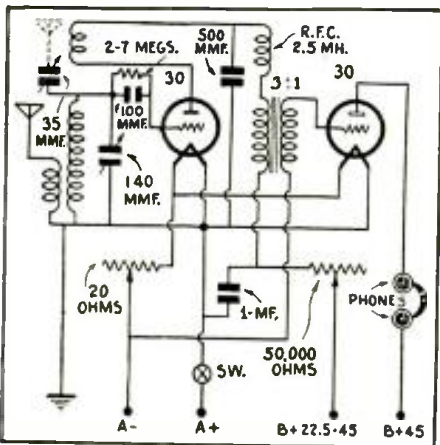

Here is the diagram of the "All-Purpose" receiver, which appeared in the April, 1933 issue.

gram of the "All-Purpose" Receiver which used two type 30 tubes? The receiver was recently published in the issue in which the picture of the Oscillodyne was on the cover.

(A) The All-Purpose Receiver was very popular with our readers and we are very pleased to reprint the diagram for you. The values for the parts are all given and you should obtain excellent results with this 2-tube set.

## 2-TUBE RECEIVER DIAGRAM

H. Aitkenhead, 924 Tuxedo Blvd., Webster Groves, Mo.

(Q) Would you be kind enough to print a selective and sensitive 2-tube receiver using a 57 regenerative detector and a 56 resistance coupled audio amplifier, to which I

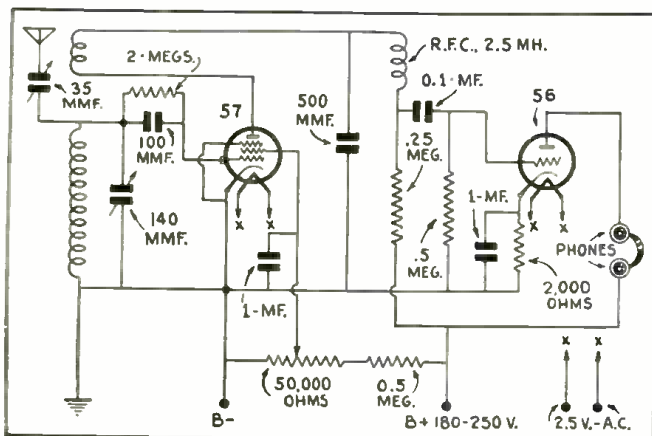

Diagram of a 2-tube receiver using 57 and 56 tubes. Coil data was given in the July Question Box.

## EDITED BY

GEORGE W. SHUART, W2AMN

● Because of the amount of work involved in the drawing of diagrams and the compilation of data, we are forced to charge 25c each for letters that are answered directly through the mail. This fee includes only hand-drawn schematic drawings. We cannot furnish "picture-layouts" or "full-sized" working drawings. Letters not accompanied by 25c will be answered in turn on this page. The 25c remittance may be made in the form of stamps or coin.

Special problems involving considerable research will be quoted upon request. We cannot offer opinions as to the relative merits of commercial instruments.

Correspondents are requested to write or print their names and addresses clearly. Hundreds of letters remain unanswered because of incomplete or illegible addresses.

could add an R.F. stage in the future. I have a set of two-winding coils that I want to use in this receiver.

(A) A 2-tube receiver using a 57 and 56 is printed on this page and it is one of the most sensitive type of regenerative receivers that you can build. An R.F. stage can easily be added at any time.

## TRANSFORMER HEATS

Donald Pratt, Harpersville, N. Y.

(Q) I have a transformer that I want to light a 27 tube from the 110 volt line (A.C.). The voltage is a little too high on the secondary winding—it heats up so badly I cannot use it. What could I use to obtain the correct voltage?

(A) If your transformer heats considerably there is no method of eliminating this trouble unless you wish to rewind the secondary with heavier wire. The voltage could easily be cut down with the resistance but due to the fact that the transformer heats up there is little use of continuing to use it, because the wire is evidently not heavy enough to carry the load of a 227 tube.

## REVAMPING OLD SUPERHET

D. D. Keller, c/o Lowndes County ERA, Valdosta, Ga.

(Q) I have one of the old "RCA" 6-tube superheterodyne sets, on the plate which appears on the front of the cabinet are the words "second harmonic." My interest lies in rebuilding this set into a short-wave unit. For power supply, I have an "A" and "B" eliminator which was used on a Kellogg set. Would appreciate any information or data you could give me.

(A) Due to the design of the particular receiver you have, we do not believe it would be advisable for you to make it into a short-wave set. Several of our friends have tried unsuccessfully to make a short-wave super

out of an old second harmonic set. The sensitivity and selectivity in all cases were very poor. We believe you would be much better off to build a more up-to-date set, following some of the designs set forth in the various issues of SHORT WAVE CRAFT.

## THE "19-TWINPLEX" RECEIVER

Frederick Miller, 38 Stamford, Boston, Mass.

(Q) Will you please publish a diagram of a receiver using a 19 tube and four-prong coils?

(A) The "19 Twinplex" receiver has proven to be one of the most popular sets that we have described in quite some time. Naturally, it would be quite popular with the "beginner" because really only one tube is used, while 2-tube performance is obtained. We print herewith a diagram for you, together with the values of the parts. Coil data for this receiver can be obtained

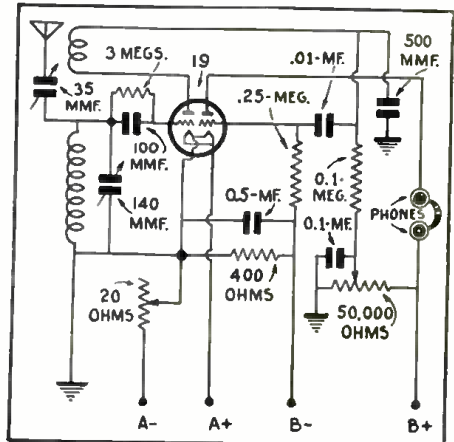

Above we have the diagram of the 19 Twinplex receiver.

by referring to the July, 1934 issue of SHORT WAVE CRAFT.

## TWO STAGE AMPLIFIER

Henry Laureys, 370 Webster Ave., Jersey City, N. J.

(Q) Please publish in the Question Box a circuit of two stages of audio, using one 53 tube. Phones are to be connected to the first stage and a speaker to the second. If the above is not as good as using separate audio tubes, such as two 56's, please mention it.

(A) We believe the two stage audio amplifier shown in the diagram will work much better than a single type 53 tube, using one stage of resistance coupled audio. Most audio volume can be obtained from the two type 56 tubes with transformer coupling.

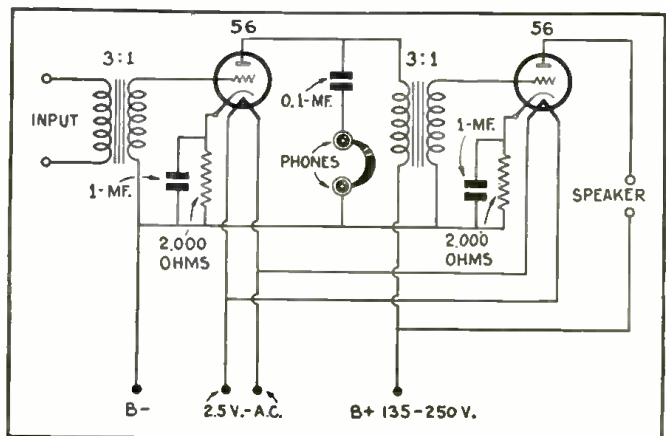

Two stage audio amplifier, showing the connections together with the values of the parts.

# When You Talk To A Ship At Sea

(Continued from page 391)



The map, above, shows "round-the-world" route followed by the S.S. "Empress of Britain"; during this 25,000 mile journey telephone calls were put through regularly to and from ship. Diagram, right, shows line-up of short-wave receiver at the land station located at Forked River, N. J.

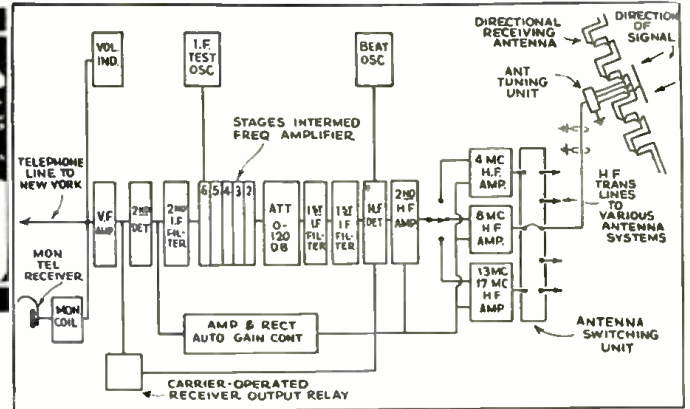

reactance networks. The object of this *time delay* panel is to give the voice-operated relay, which switches the transmitting and receiving circuits, time in which to operate without cutting off the first and last syllables of the words of a sentence which you have just spoken. The Vodas (which in radio-telephone language means "Voice Operated Device Anti-Singing") (comprises in its elemental form a highly sensitive, specially designed, polarized relay, which is so sensitive that it will operate on but one-half milliamperes. These relays can operate extremely fast and, in fact, do their work in less than a hundredth of a second. In the time delay panel there are twenty groups of *time delay* resistance-reactance networks, each of which delays the speech one thousandth of a second or twenty-thousandths of a second for the whole group of twenty units.

Suppose you have just finished a sentence and are ready to listen to the person aboard ship talk back to you. As soon as you have pronounced the last word or, in fact, a fraction of a second after that, thanks to the *time delay* mechanism, the Vodas, or voice-

operated relay, connects the circuit to the receiving line coming in from the short-wave receiving station at Forked River, simultaneously blocking off the transmitter circuit at Ocean Gate.

As soon as the last word of the sentence on the incoming short-wave phone voice from the ship has been pronounced, the voice-operated relay switches the circuit so that your next sentence or sentences will be transmitted.\*

A most remarkable set-up of radio, telephone and electrical apparatus has been perfected by the coordination of many special engineers and physicists of the A. T. & T. Company and its associated laboratory and consulting staffs. Following the usual telephone practice, the voice currents are amplified along the line between New York and the transmitting and receiving stations proper, located at Ocean Gate and Forked River, the vacuum-tube amplifiers serving to boost the voice currents in order to compensate for electrical losses occurring along the lines are located at Asbury Park. Such amplifier or repeater stations are usually located at points approximately fifty miles apart on long distance telephone lines.

## Shore-Ship Traffic Available Half-Way Around the World

On the last "around-the-world" cruise of the beautiful steamship *Empress of Britain*, frequent radiophone contact was established with radio stations of the A. T. & T. Company at San Francisco and New York, which enabled more than 100 of her passengers to talk with friends and relatives in every quarter of the U. S. and Canada. After the *Empress of Britain* reached the vicinity of Singapore, contact was established with the A. T. & T. Company's powerful radio transmitting and receiving stations located at San Francisco. Remarkable as it may seem, and considering that the ship had only a 1,000 watt transmitter, these telephone calls by wire and short wave radio were executed in fine order; there were 40 phone calls to points in Massachusetts and California, Texas, Florida, Wisconsin, and other states in this country, as well as Canada, while the *Empress of Britain* was steaming along between Singapore and Hong Kong. Most of these calls involved short-wave and wire phone circuits of 10,000 miles and more in length. 13,000 miles was the gap spanned in one call put through between Halifax, N. S., across the American continent and the Pacific Ocean to the *Empress of Britain*.

One kilowatt telephone short-wave transmitters are now carried by the *S.S. Rex*, *Conte de Savoia*, the *S.S. Leviathan* carries a 500 watt transmitter; the *S.S. Bremen*, an 800 watt transmitter, while others in the group of 21 ships equipped to carry on ship-to-shore telephone service for its passengers, have transmitters rated from 200 to 500 watts; the *S.S. Majestic* has a 2 kw. transmitter, as has also the *Olympic*.

For the longer distances, the frequencies or wavelengths used about the middle of August were as follows: For daylight transmission, average wavelength employed was 22 to 35 meters; for night-time transmis-

(Continued on page 424)

## Transmitting and Receiving Stations

The accompanying photographs show the appearance of the 20 kw. transmitter located at Ocean Gate, N. J., and a special antenna is used at this point. One of the photos shows the appearance of the large 10 kw. vacuum tubes used in the transmitter at Ocean Gate. There are several antennas erected at the transmitting station each designed of the proper size for a certain frequency and wavelength and these can be switched into service selectively in the transmitter operating room.

The short-wave voice "signals" picked up from ships at sea are intercepted on the special short-wave aerials of the receiving station at Forked River, N. J.

\* (The following description of the Vodas may help to make its action clearer and was written by one of the A. T. & T. Co., engineers.—Editor.)  
 "The voice-operated mechanism normally is set up to permit voice frequencies to come through from the radio receiver, and prevent any of these frequencies from going out to the radio transmitter.  
 "As soon as the subscriber on shore talks, his voice operates the transmitting side of the Vodas and clears a pathway to the radio transmitter, at the same time blocking the pathway from the radio receiver. When the subscriber stops talking the Vodas blocks the transmission path and permits the shore subscriber to hear anything coming from the radio receiver.  
 "When the person aboard ship talks, the received speech at New York operates the receiving side of the shore Vodas to disable (block) the shore transmitting side and thus prevent re-radiation from its radio transmitter.  
 "A certain amount of time is taken to operate the voice operated mechanism, and while waiting for this operation syllables of speech might be clipped. The (time) delay network prevents this by slowing the speech in its travel, sufficiently to permit the Vodas relays to operate and let the syllables slip through."

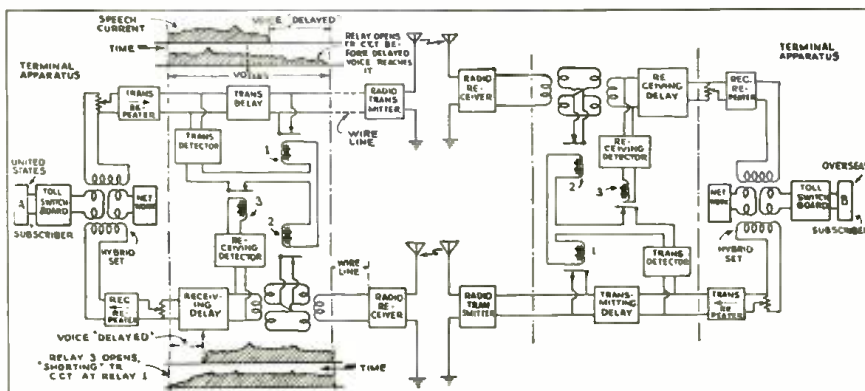

Above—Area now covered by the "ship-shore" radiophone service of the A. T. & T. Co. A person anywhere in the U. S. or Hawaiian Islands can talk to any one of 21 ships now plying the Atlantic. Left—Diagram of the "Vodas".



**FREE**  
 THE BIGGEST-LATEST-MOST COMPLETE  
**1935 RADIO CATALOG**  
 192 PAGES OF RADIO BARGAINS  
 OVER 50,000 ITEMS  
 BIG S.W. SECTION  
 GREAT P.A. DEPARTMENT  
 NEW REFRIGERATION DEPARTMENT  
 ALL NATIONALLY KNOWN LINES



**A Bargain Book of 192 Pages that will SAVE YOU MONEY**

**T**HIS AMAZING new 1935 Radio Catalog is the last word . . . the greatest Bargain Book of Radio ever published by us or any other company. There are more pages, more items listed, more nationally known lines, more Specialized Departments. Over 50,000 items have been assembled in this great 192 page book to make it the outstanding book of the Radio Industry.

There is a Special Department on the latest Broadcast and All-Wave Receivers from 2 to 10 tubes. You'll find an entirely new Department on REFRIGERATION PARTS and accessories—a new money-making field for Servicemen. A whole section on PUBLIC ADDRESS is the most complete and all-inclusive thing of its kind.

Then there is our matchless SPECIALIZED SHORT WAVE DEPARTMENT which in itself is a complete catalog listing everything the Ham, Brasspounder and Experimenter will ever need. Sets, Kits, Transceivers, Pre-selectors, Converters, as well as other Short Wave parts and accessories. Practically every nationally known manufacturer is listed here. The complete list reads like a Who's Who of Radio . . . and everything is at LOWEST WHOLESALE PRICES!

For 13 years the "WHOLESALE" Catalog has been the Serviceman's "Bible". Today the greatest Radio Catalog ever printed—backed by the resources of the greatest organization of its kind in the world—is yours for the asking. GET YOUR'S TODAY!

**ALL STAR S.W. KIT**

Build it yourself! This revolutionary sensation in the Short Wave Field was designed by 8 leading manufacturers. All of their experience in designing and manufacturing has gone to make this a Super-het that outperforms anything of its kind! Features that guarantee good foreign reception include: Continuous Band Spread, 10 to 500 Meter Tuning Range, 6 Tubes, Pre-Adjusted Coils, etc.

Be sure to write for complete circuit diagrams, parts list and data sheet — **FREE!**



**Lafayette "19" Transceiver for 5 m. Communication**

A new Transceiver that really gets out and lets you do things. One of the most powerful portable units ever offered in this class. Using a type 19 tube in a p.p. oscillator, it has a power output of approx. 2 watts (about 10 times the power of units in this class). More than enough is obtained for speaker operation if desired.

The Lafayette "30" is similar to above except that it uses a type 30 tube as the oscillator for transmitting with type 33 pentode as modulator providing a strong signal that is clearly understood.

Both models were developed after research in both laboratory and field. Entirely self-contained. Weight but 26 lbs. complete with batteries. Write for complete information.



**WHOLESALE RADIO SERVICE CO.**  
 Main Office and Warehouse  
**100 SIXTH AVENUE • NEW YORK, N.Y.**

WHOLESALE RADIO SERVICE CO.,  
 100 Sixth Ave., Dept. SW-114, New York, N. Y.

Send me your new 1935 Catalog No. 56.  
 Send me free data on the All Star Kit.  
 Send me free details on the Lafayette Transceiver.

NAME .....

ADDRESS .....

CITY..... STATE.....

Serving the South and Southwest  
 430 W. PEACHTREE ST. N.W. - ATLANTA, GA.

Serving Northern New Jersey  
 219 CENTRAL AVE. - NEWARK, N.J.



**Talking To Ship At Sea**

(Continued from page 422)

sion 63 to 70 meters. It is interesting to note that a different wavelength or frequency is used to carry the voice to the ship than that employed to transmit the voice from the ship. For example, if 63 meters was the wavelength used to transmit from the Ocean Gate station to the ship at a given time, the ship used a wavelength of 70 meters to shore. At the shorter distances another but similar schedule of wavelengths is used.

You will probably assume that the transmitting and receiving apparatus aboard the ship is an exact copy of that used at the land station, but this is not the case, as the ship's set is not equipped with the *time delay* or *voice-operated relay* (Vodas). The telephone set used by the person aboard ship has two wires connected to its microphone and these connect direct with the radio-telephone transmitter in the ship's radio cabin. The two wires coming from the receiver connect with the ship's radio telephone service receiving set. Aboard ship two distinct aerials are used, one for the transmitter and one for the receiver. When the ship's passenger is listening to your conversation from the land station, an automatic relay cuts off the ship's carrier wave and, as soon as he speaks, the relay puts the carrier on the transmitting antenna.

On nearly all of the 21 ships sailing the Atlantic and fitted for ship-shore radio telephone service, the passenger makes or takes the call in a specially fitted cabin set aside for the purpose. On the *Empress of Britain* the passenger may call from his stateroom.

As in the case of various point-to-point transoceanic short-wave radio-telephone circuits operated daily by the A. T. & T. Company, and now available to the public, the wavelengths used at different times of the day or night, and especially during the changes of the seasons, are selected and changed in accordance with the best results obtained. These frequency or wavelength changes follow roughly a regular schedule, being shorter at one season of the year and longer at another, all of the important points such as quality and strength of speech received, variations in strength due to a magnetic storm, sun-spots and other cosmic phenomena.

**Over 50 "Foreign" Countries in Short-Wave Net**

Thanks to *short waves* and cleverly engineered and balanced telephone wire circuits across the continents some fifty-three "foreign" countries are now available to the Bell telephone subscriber. A man may call from Sedalia, Mo., and ask to be put in telephone communication with a person in the Philippine or Hawaiian Islands, Dutch East Indies, and various locations in Europe, Africa, and Australia, or important centers in South America, ships-at-sea, as well as most of the Central American countries. In other words, *short waves*, plus wire phone circuits, now make 92 per cent of the world's telephones available to you.

It is almost unbelievable to think for a moment that today shore-to-ship service is available to any telephone subscriber in the U. S., Canada, Cuba and Mexico, as well as those in other countries, and this service is now offered to four islands in the Hawaiian group. In other words, a person can put through a telephone call from Honolulu by *short waves* to San Francisco, thence by wire to New York, by wire to Ocean Gate; and then by *short waves* to a ship practically anywhere in the Atlantic. The same person could also, of course, be switched on to the short-wave link to London and talk through the London station to any one in the British Isles or in most of Continental Europe. The same call may be switched from New York on to the Central American, Bermuda or South American circuits.

The following ships are now equipped with radio telephone for public service: *Albert Ballin, Deutschland, Hamburg, New York, Monarch of Bermuda, Queen of Bermuda, Bremen, Columbus, Europa, Homeric, Majestic, Olympic, Empress of Britain, Rex, Conte di Savoia, Leviathan, Aquitania, Caldonia, Isle de France, Resolute, Berengaria.*

**BUD Presents — New GIANT PLUG-IN COIL FORM**

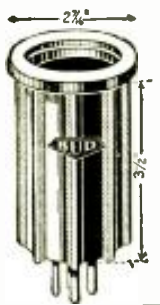

An ideal form for Transmitter Inductances and Long Wave Receiver Inductances and numerous other uses. Made of special low loss bakelite. Bakelite body of coil form is 2 1/4" in diameter and 3 1/2" long. Winding space 3 1/4". Standard base to fit either 4, 5 or 6 prong sockets. Eight ribs, extending 1/4", insure low loss air core windings. Top of form has moulded grip ridge.

- No. 734—4 Prong..... 75c
- No. 735—5 Prong..... 80c
- No. 736—6 Prong..... 85c

**Bud Socket Housing**

Is designed especially for front panel mounting of tubes on Transmitters, Scientific Instruments, Sound Amplifiers, etc. With this unit you have easy access to the tubes. Made of cast Aluminum. Very rugged in construction. Finished in baked Krinkle Enamel. Three mounting screws hold housing securely to panel. Height 1-5/16", width 3", depth 3 3/4". Socket hole 1 3/8" diameter. Socket mounting hole centers 1-11/16".

No. 1121—Price \$ .60

**Bud Transmitting Chokes**



A uniformly built choke with unusually low power loss and no transmission bands. Continuous winding of six lateral wound tapered sections; mounted on Isolantite core with tapped hole on each end. Choke can be mounted directly to metal panel or by the metal mounting brackets furnished. All individual coil resonance and anti-resonance points blocked by at least two other coils of the series, permitting effective choking on all high frequencies. Overall size, 2" wide by 3 1/4" long (less brackets).

No. 569 is recommended for use in plate circuits of high and low powered transmitters. No. 568 is recommended for grid circuits. Intermittent load 50% above rated current capacity.

No.	Ind.	Dis. Cap.	Current	D.C. Res.	Price
568	2.8 M.H.	1 MMFD	1000 M.A.	5 ohms	\$2.00
569	5.3 M.H.	1 MMFD	500 M.A.	12.5 ohms	\$1.75

**Hy - Freq. R. F. Chokes**

For all types of high frequency receivers and low powered transmitters. A continuous four pie winding. Mounted on Isolantite Core. Heavy strap leads permit numerous ways of mounting. Extremely low distributed capacity.

Catalogue No.	920	922	923	924
Induct. M. H.	2.5	5.5	8	10
Dist. Cap. MMFD.	1	2	2.5	3
D. C. Res. Ohms	45	60	72	78
Cor't. Rating M. A.	125	100	100	100
Price	65c	80c	90c	\$1.00

Listed above are but a few of the items in the complete BUD line. Write for New 1935 Catalog! All list prices shown in this advertisement are subject to 40% discount when purchase is made from an authorized BUD jobber. If your jobber cannot supply BUD parts, send your order direct to us together with your jobber's name and we will make shipment direct.

**BUD RADIO INC. 1937 E. 55th STREET CLEVELAND, OHIO**

**I GUESS I'M A FAILURE AT THE CODE—CAN'T MAKE ANY HEADWAY**

**I SAID THE SAME THING UNTIL I GOT WISE TO THE INSTRUCTOGRAPH**

**Passed Code Exam. Easily**

Like many others, I fooled away months trying to learn the code from a Short Wave Receiver, without making any headway. Then I got wise to the Instructograph Automatic Code Teacher, and in almost no time passed code exam, easily. Don't be misled. Every intelligence as well as Extension Schools use a machine with a perforated tape to teach their classes. Government examinations for Amateur and Commercial tickets are always given by a machine, using a perforated tape. If there was a better way, the large schools and Government would have it.

**Instructograph Automatic Code Teacher**



**Provides Necessary Code Practice**

No waiting for code schedules which you can seldom tune in when wanted—no annoyance trying to keep the station tuned in and copying. Instructograph provides all the code practice needed to become a real operator. Instructions accompanying Instructograph show how to practice to the best advantage just like an instructor would do. Failure impossible.

**Terms as Low as \$2 per Month**

Anyone wishing to learn the code and qualify for Amateur or Commercial examinations, or increase their speed to the Standard of a real operator—should get an Instructograph without delay. Rent it for a month. Be convinced it is the best way to learn the code and become a real operator. If not, send it back. Terms as low as \$2.00 per month. Write for details NOW!

**INSTRUCTOGRAPH COMPANY Dept. SW-11 912 Lakeside Place Chicago, Ill.**

**CHASSIS for YOUR PORTABLE**



All drilled and with handle attached, Beautiful crackle finish... **\$ 2.95**

We also make chassis for any receiver. Send drawing or give complete dimensions for estimate.

**KORROL MFG. CO., Inc. Dept. S-11 232 GREENWICH ST. NEW YORK CITY**

**Write to TRY-MO for FREE CIRCUIT DIAGRAM AND PARTS LIST**



**THE LATEST RADIO SENSATION**

We can make immediate delivery of all the necessary parts at the lowest prices. Be sure to write us.

**Try-Mo Radio Co., Inc. 855 Cortlandt St. New York City**



## Fun With 5-Meter Trans-Ceivers

(Continued from page 410)

anyway and a knob permits quick scanning of the entire five-meter band.

The three tubes in the Lafayette Transceiver actually do the work of five. Tubes V1 and V3 are both type 19 double triodes, V2 a type 30. The four switches marked S are all part of a single four-pole, two-position unit; the points marked T represent the transmit position; the points R the receive position. The variable resistor R1, which acts as volume control, is combined with the filament switch SW. C1, R1 and S are the only variable instruments in the whole transceiver.

The coil marked L1 looks a bit peculiar. It consists of two turns of 1/4-inch copper tubing about 2 inches in diameter, with a split length of insulated flexible wire inside. The tubing acts as the plate coil, the inside wire as the grid coil, of a simple push-pull oscillator. The close coupling between the two coils makes this a powerful oscillator indeed.

Let us throw the changeover switch to the receiver position and see what happens. Tube V1 now acts as a self-quenching super-regenerative detector, with C4-R3 as the grid condenser leak combination. Transformer T1, with primary P1 functioning, acts as an ordinary amplifying transformer, working into V2 as first audio stage. V2 in turn feeds into T2 and V3, which act together as a complete class B audio output stage, the output transformer T3 operating the earphones. Simple, isn't it?

Now switch to the transmit position, and the same parts act altogether differently. V1 becomes a push-pull oscillator. Primary P2 of transformer T1 is cut in, and T1 becomes a microphone coupling transformer. V2 is now a speech amplifier, and V3 a class B modulator. The secondary of T3 is switched from the phones to the plates of V3, so T3 is now the modulation transformer. Simple again, isn't it?

In the receive position R1 is a volume control on the received signals. In the transmit position it is a mike gain control.

Two binding posts are provided on the top of the case for antenna or feeder connections. The writer has obtained his best results with a quarter-wave antenna consisting of a four-foot length of aluminum tubing, fitted at one end with a threaded brass insert that screws directly to one of the stand-off insulators. An eight-foot half-wave antenna has also been found good. The four-foot tube is convenient because it is shorter. It is especially valuable in a car in motion, as it whips around less.

For power supply, dry batteries are used throughout. Two standard No. 6 dry cells light the filaments. Three 45-volt B batteries energize the plates. A 7 1/2 volt C battery furnishes bias for V2. A separate 4 1/2 volt C battery is used for microphone current, one of the switch sections opening this circuit when the transceiver is in the receive position. A single set of batteries has withstood two months of experimental service, and still seems to be all right.

As for actual results—the writer worked more than 10 miles "blind", between 100 6th Ave., New York, and outlying sections of the city. Some of the contacts were made with stations apparently blanketed by steel buildings. In fact, one QSO was accomplished with this transceiver on the fifth floor of a 17-story steel building, and the other station about three miles uptown!

### Parts List for the "Lafayette" Transceiver

- C1—15 mmf. midget.
- C2—.002 mf. mica.
- C3—.002 mf. mica.
- C4—.00025 mf. mica.
- C5—.004 mf. mica.
- C6—.0005 mf. mica.
- R1—1 megohm.
- R2—5,000 ohms.
- R3—200,000 ohms.
- R4—1.5 ohms.
- L1—Tank coil as described.
- T1—Special Lafayette double primary transformer.
- T2, T3—Class B, A.F. transformers.
- V1, V3—Type 19 tubes.
- V2—Type 30 tube.



# NOW! The Fultone V

Sensational New Five-in-Three Set  
6F7 76 12A7

Here Is Your Ideal Short Wave Receiver  
The FULTONE V Combines  
Every Worth While Feature Known!

## I—ALL ELECTRIC! A.C.-D.C.! HUM FREE! ENTIRELY SELF CONTAINED!

The Fultone V priced at \$6.95 represents an indisputable value. It requires no batteries or outside power pack, being entirely self-contained. Plug in directly to any A.C. or D.C., 110 volt outlet and it is ready to operate. The speaker compartment at the right end of the set takes our special speaker priced at \$1.45. If you wish you may also use headphones for which convenient provision has been made. Perfect filtering has been provided so that all hum is eliminated. Clear, crisp reception is only one of the features!

## II—THREE TUBES DO THE WORK OF FIVE! LOUD SPEAKER VOLUME!

A marvel of engineering skill, three tubes have been used to give the results of five powerful modern tubes. Here's how it is done—the 6F7 tube contains a cathode, six grids and two plates. Five grids and a plate are used as the first R.F. pentode. The remaining grid and plate are the detector tube. High gain system of coupling is used between these tubes. The 76 is the powerful first A.F. amplifier. The 12A7 contains two sections in one envelope. One section is the second A.F. Power pentode output tube. The other is the power rectifier tube. Here's the line up—First R.F.—detector—first A.F.—second A.F.—rectifier. No wonder the distant stations come in with a wallop!

## III—FUNDAMENTAL 12,500 MILE CIRCUIT! MEANING REAL DX!

The well-known 12,500 mile circuit needs no introduction to short wave fans. It is notable for its high sensitivity and volume. This circuit is the heart of the Fultone V, and it is here that the skill of the design engineer really counts. By careful design coupled with sufficient simplicity to make this the ALL-FAN set, the Fultone V is finding its way into the "black" of every S.W. listener and amateur. By actual tests, the results obtained from the Fultone V have been demonstrated to be far superior to those from sets costing more than twice the price. The circuit has been so designed that control of regeneration is smooth over the entire tuning range with no dead spots or bumps; variation of the regeneration does not shift the tuning. A station once picked up will always reappear at the same dial setting. No longer need you look with envy at multitube sets costing a small fortune. The Fultone V places real world-wide reception within the means of every radio listener.

## IV—HIGHEST GRADE PARTS USED! FOOLPROOF!

By careful selection, we have placed in this set the finest parts necessary. Ample leeway has been allowed in all components so as to insure long life. The filter condensers are rated at double the voltage needed; all other condensers are rated at from 300 to 500 volts. A large vernier dial is used to provide easy, sure tuning. The tuning condenser is sturdy, smooth action. Finest grade bakelite insulation is used throughout. A heavy all metal chassis and panel is supplied with every kit, with all holes already drilled. Four coils covering from 15 to 200 meters; in fact every necessary part down to hook-up wire and the last nut and screw is supplied. Included with this are detailed wiring instructions and large drawings.

## V—EASY TO BUILD! THE PRICE IS LOW!

Two drawings are supplied. One is a schematic diagram for the advanced constructor. The other is a large picture diagram, so clear that the beginner in radio can construct the set with ease. The price is so low it will amaze you. Why? We want to make it possible for you, no matter what your means, to own the set, and thrill at the finest in Radio. The price of the complete kit (less only the accessories listed below).....

**\$7.75**

- Set of Three Matched Sylvania Tubes.....\$2.20
- Attractive Metal Cabinet with Hinged Lid.....\$1.25
- Special Loud Speaker.....\$1.45
- Two Coils, 200-625 Meters. Makes Set All-Wave \$1.25

—SPECIAL COMBINATION OFFER—  
Complete Kit, Tubes, Speaker,  
Cabinet and B.C. Coils..... **\$12.75**

THE FAMOUS 12,500 MILE TWO TUBE SET—THE GREATEST SHORT WAVE VALUE TODAY! Available Both in Battery Model and AC Model. In keeping with our policy of giving you the best for the lowest price we are maintaining the price of these well known kits at..... **\$4.45**

\$4.45 brings you this two tube kit complete with metal chassis and panel, already drilled, Hammarlund tuning condenser, KK vernier dial, set of four coils—15 to 200 meters, every necessary part, etc., complete detailed instruction—\$4.45.

## Are You a Set Builder?

Are you going to construct any of the sets described in this magazine? If so, you will surely want our special parts list for that set! A clear tabulation of all the specified parts with our low wholesale prices and also a list of less expensive substitutes that will function perfectly. You can order one part or the entire kit and save money!

Send Now!! No Obligation!  
(Mention title, page, and month)

- Cabinet for either model.....\$1.00
- Set of two broadcast coils, 200-625 meters.....\$1.25
- Complete antenna kit.....\$.75



DEPOSIT REQUIRED

Any Kit on this page — Assembled — Wired and Tested — **\$1.25**

## HARRISON RADIO CO.

Dept. C-11 New York City  
142 Liberty Street

★ ★ THE HOME OF FOUR STAR SERVICE ★ ★

## Fastest Way to Learn CODE

Easy, Fascinating;  
LEARN BY EAR  
to Be a Good Op!

The New MASTER TELEPLEX Code Teaching Machine is exactly what thousands are looking for. Has taught code to more operators in past ten years than other systems. No experience needed. Ideal for beginners—steps up w.p.m. for all ops. Teleplex doesn't merely show you code—it IS code! You actually HEAR the dots and dashes, any speed you want. You learn code the way you'll be using it—by SOUND! Teleplex also sends back to you; im-possible with any other system. Complete Code Course included, no extra charge. Used by U. S. Army, Navy, R.C.A., A.T.&T. Co. and others. Low cost, easy terms. Money-back Guarantee. Send now for booklet 8, 23, no obligation. Postcard will do.

TELEPLEX COMPANY  
76 CORTLAND ST. NEW YORK, N. Y.

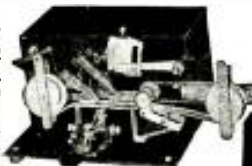

## WORLD WIDE ALL WAVE RADIO

A real powerful long and SHORT WAVE Radio Receiver that actually gets local and foreign broadcasts, police, amateur airplane, etc., transmissions direct! Thousands now in use. Owners report reception of Foreign Stations with amazing volume. Works on two inexpensive batteries. Not a toy! RESULTS GUARANTEED!

**\$195**

ACE construction kits have all necessary parts mounted on attractive metal chassis and panel, all ready for wiring. Clear picture diagrams. Wire it yourself. It's easy. Range 15 to 600 meters. Complete Kits, with coil—  
● ONE TUBE KIT, \$1.95 ● TWO TUBE, \$2.85  
ALL ELECTRIC 105-125 Volt AC-DC two-tube house current set. No batteries needed! Complete Kit., \$3.65  
Kits wired, 75c extra. Tubes, 85c ea. Double phones, \$1.25  
ORDER NOW! Send \$1. balance C.O.D., or if full remittance with order, we pay postage. Free literature.  
Large color map of the World, Valuable Short Wave data, etc.! Send 10c for handling, NOW!!  
**FREE!!**  
ACE RADIO LABORATORIES  
1619 Broadway Dept. C-11 New York City





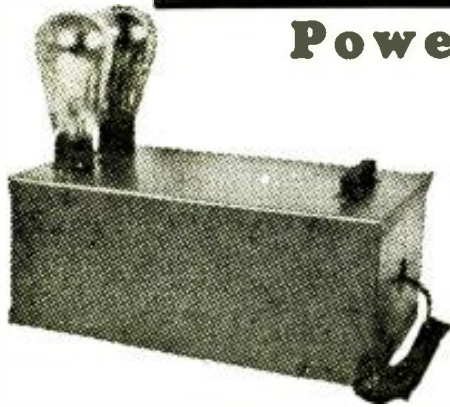

## Power Supplies

FOR PHONE

No.	D.C. Volts	Mills	Rectifiers	Price
1	600	150	2-81s	\$ 9.00
2	600	170	2-81s	11.00
3	750	150	2-866	15.00
4	750	170	2-866	17.50
5	1000	175	2-866	21.00

## Fine Chassis Transmitters

MODEL T-6, 10 WATTS—Steel Chassis Type  
Uses 2 UX 245 tubes, the output being 10 watts, and is furnished with Readrite Millimeter. Less power or tubes. Price.....\$7.00

### MODEL T-7, 30 WATTS

Uses 2 UX 210 tubes, the output being 30 watts, and is furnished with Triplett Millimeter. Less power or tubes.

Price .....\$15.50

### MODEL T-8, 40 WATTS

Uses 2 830 tubes, the output being 40 watts, and is furnished with Triplett Millimeter. Less power or tubes. ....\$17.95

Send Stamp for Catalog covering complete Amateur Transmitting equipment.

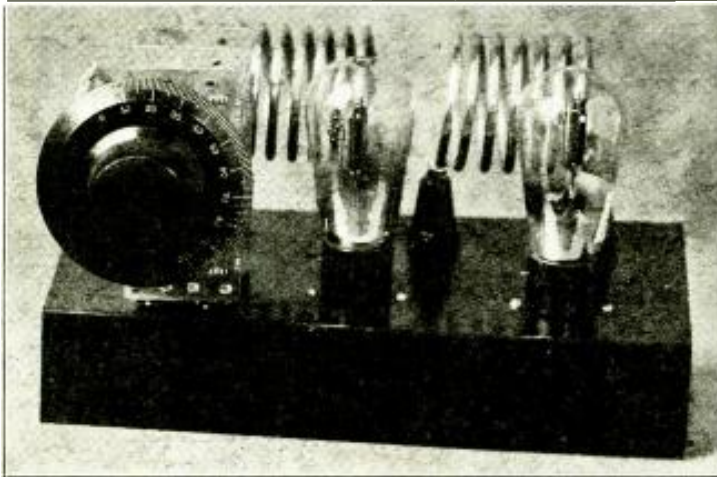

## More Power on 2.5 Meters

(Continued from page 399)

mitter is ideal; the addition of another tube only incurs additional losses in the circuit using open lines. Theoretically the lines having both ends open must be a half wave long. However this is not possible with the present-day tube construction, because the grid and plate of the vacuum tube actually becomes part of the line. Special tubes will no doubt be released in the near future. The match between the external part of the line and the tube is not perfect by any means, but the dimensions given are a fair compromise.

### New 801 Type Tube Used

When designing his type of transmitter the new RCA 801 tube was used. The elements of the tube proved to be equal to approximately one foot of line. In other words subtract one foot from a half of the wavelength on which you intend to work. For 2.5 meters the line will be 36 inches long. This shows that the shortest wavelength at which this tube will function properly in the circuit described is 1.25 meters. Incidentally you will be surprised at the amount of R.F. generated by a transmitter of this type on 1.25 meters. Other types of tubes will require slightly different lengths of external line which will have to be determined experimentally.

Other types suggested and which are best

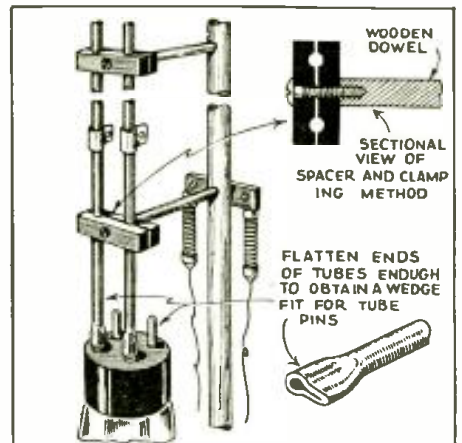

Details of 2.5 meter Transmitter.

suited are the 12A, 171, 201A, 245 and the 210. The 800, of course, is very fine for the higher powered "rig", the use of which will require a line slightly longer than the above-mentioned types.

Referring to the photograph we find that the voltage curve of the line has been plotted and photographed with the transmitter. Starting at the end of the line we find that we have a point of high voltage. As we proceed down the copper tubes we have a decrease in voltage, until we reach a point where the curve crosses the line; this is a point of minimum voltage and the distance between this point and the end of the line is exactly one-quarter of the wave-length on which the transmitter is operating. At this point the grid return and the plate voltage leads are connected, through the small R.F. chokes. This makes it easy to check the wave-length; it can be done with a yard stick. The length of the antenna is also governed by this distance—it is just twice this long for a half-wave radiator.

### Construction Hints

Construction of the transmitter is not at all difficult. The drawing shows how the ends of the 1/4 inch dia. copper tubes are squeezed together in order that they will push on the plate and grid pins of the vacuum tube. This eliminates long connecting leads from the line to the tube connections. The mounting which supports the oscillator consists of a 1/2 inch dia. dowel stick 36 inches long, set into a wood base-

The GENERAL ENGINEERING CORPORATION Charlotte, Michigan, U. S. A.  
Also Distributed by AMERICAN SALES CO., 44 W. 18th St., New York City; ALLIED RADIO CORP., Chicago;  
RADOLEK COMPANY, Chicago; BURSTEIN-APPLEBEE CO., Kansas City, Mo.

## ★ THOR SHORT WAVE WINNERS ★

### The Ever Popular

RGH4 won the June "Short Wave Craft" Prize. Thousands of letters received since praising the circuit. Confirms the choice of experts. Complete kit of highest quality parts, including Short Wave Coils. Short Wave 4 Tube A.C.

**\$10.95**

With 6 inch Dynamic Speaker. **\$12.95**



### RGH 5

SENSATIONAL 5 TUBE A.C. RECEIVER

### GOTHIC RGH 5

Bob Herzog's latest Short Wave sensation. Unique in design. Makes coil changing a speedy, simple operation.

Specially constructed chassis and Cadmium plated panel with Gothic shaped recesses for inter-changeable coils, accessible from the front — MARVELOUS SENSITIVITY. EASY TO WIRE.

**\$12.95**

DYNAMIC SPEAKER **\$2.50 EXTRA**

## FREE — Kits Mounted — FREE

KITS SHIPPED RED-MOUNTED FOR EASY WIRING  
IT'S A CINCH TO BUILD IT—YOU CAN'T GO WRONG

## THOR'S BARGAIN BASEMENT

167 Greenwich Street

Dept. S

New York City

MAIL ORDERS FILLED

FREE TECHNICAL DATA

## WHEN CHOOSING A RADIO SCHOOL



RCA Institutes, with its reputation established by 25 years service, is an institution recognized as an important factor in the radio industry. Whether elementary radio principles or advanced subjects, sound applications or practical radio engineering, RCA Institutes is prepared to give you the instruction you need.

RESIDENT SCHOOLS NEW YORK AND CHICAGO with modern standard equipment

EXTENSION COURSES FOR HOME STUDY under convenient "no obligation" plan.

Illustrated Catalog on Request.

R.C.A. INSTITUTES, Inc. Dept. SW-34  
75 Varlek St., New York—1154 Merchandise Mart, Chicago

## Vest Pocket SOLDERING IRON



Smallest Good Iron now on the market. Will do the work of irons twice its size. Only 10 inches long, 1/2 inch in diameter. By using the highest grade elements, it heats up in half the time of ordinary irons. Guaranteed to give satisfaction or money back. We issue no catalog on this item. Enclose \$1.20 and iron will be sent postpaid in U. S. 10c extra in Canada.

GOLD SHIELD PRODUCTS CO.  
98 Park Place, S.W., New York



board of 1 inch thick stock, six inches square. Two 1/4 inch bakelite rods are doweled into the wood upright to hold the line and tube firmly. The drawing also shows the formation of the two bakelite clamps which are fastened to the ends of the 1/4 inch rods. The vacuum tube hangs in an upside-down position and two small clips are used to make the filament connections. Other details can be gotten from the drawings. The two small R.F. chokes are made by winding number 28 enameled wire on a 5 meg. resistor form. The spacing between turns is equal to the diameter of the wire. The resistor should be wound full of wire. Use a resistor having an isolantite or porcelain body.

The grid-leak used is 15,000 ohms and the plate voltage should not exceed 300 for the 801 tube. The plate current will be 100 milliamperes with normal antenna coupling. Higher plate currents will damage the tubes. Other tubes of the receiving types will require correspondingly lower plate voltages and currents.

The antenna is a half-wave long and the feeder should be connected to a point having a distance from the center equal to one-eighth its total length; the length of the feeder is not important. Tap the feeder to a point on the plate side of the line either side of the R.F. choke. This connection should be slid up and down the copper tube until a point is reached where normal plate current exists, the value of which will be between 80 and 100 milliamperes. In order to change frequency the length of the line will have to be changed. It is suggested that those interested should choose the 2.5 meter band, because if some hams are operating on 2 and some on 2.5 meters, there is little chance of working each other because some will be out of the tuning range of the other's receiver. Get organized on these high frequencies and worthwhile developments are sure to follow. A recommended power supply and modulator are shown in the drawings.

**Parts List**

- 1—Transmitter mounting (see text).
- 2—Lengths 1/2 inch copper tubing (see text).
- 2—Special R.F. chokes (see text).
- 1—15,000 ohm grid-leak (Ohmite).
- 1—75 ohm C.T. (center-tap) resistor. (Ohmite).
- 1—801 tube, R.C.A.-Radiotron.

**2-5 Meter Set Works Speaker**

(Continued from page 397)

**PARTS LIST FOR RECEIVER**

- 1—Portable carrying case, see text for details. Wholesale Radio.
- 1—6 mmf. variable condenser (large condenser cut down).
- 1—15 mmf. variable condenser. National.
- 1—100 mmf. condenser, mica. Aerovox.
- 1—.004 mf. condenser. Aerovox.
- 1—.005 mf. condenser. Aerovox.
- 1—.1 mf. condenser. Aerovox.
- 1—.01 mf. condenser. Aerovox.
- 1—15 mf. 25 volt. electrolytic condenser. Aerovox.
- 1—.5 meg. grid-leak. Ohmite.
- 1—500 ohm resistor. Ohmite.
- 1—25,000 ohm resistor. Ohmite.
- 2—250,000 ohm potentiometer. Electrad.
- 1—3:1 ratio audio transformer. Thordarson.
- 1—30 henry output choke.
- 1—5 prong Isolantite socket. National.
- 1—5 prong wafer socket. Na-Ald.
- 1—2.5 m.h. R.F. choke. National.
- 1—4 wire cable.
- 1—Small National vernier dial.
- 1—Antenna ground terminal strip.
- 1—56 or 2A5, RCA Radiotron (Sylvania).
- 1—76 or 41, RCA Radiotron (Sylvania).

**HEINIE JOHNSON**  
 Winner of the  
 First Short Wave Scout Trophy  
 Tells How to Build  
 "A S.-W. Receiver in a BOOK"  
 In the Next Issue!

**If it's a POWER TONE Receiver**  
 You are assured the **BEST** Short Wave Reception

**Universal AC-DC S.-W. Receiver**



**QUIET, hum-free reception**  
 Tubes: '78, '43 and 25Z5  
 Tunes from 15 to 550 meters.  
 Complete Kit.....\$7.95  
 Shielded Metal Cabinet. 1.00  
 Wired and Tested, extra. 2.00  
 RCA Licensed Tubes..... 3.25  
 Bruno Broadcast Coil..... .79

**5 TUBE T.R.F. A.C. Operated Short-Wave Receiver**

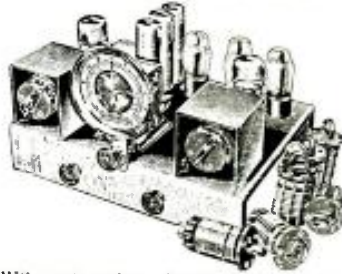

**THIS** most modern short-wave receiver is extremely efficient. It will receive foreign stations with great consistency. The tubes used are of the latest design—a '58 R.F. stage for amplification, a '58 detector, two 2A5's for the push-pull stage and an '80 rectifier.

Kit of Parts with 8 Bruno coils.....\$17.95  
 Kit of RCA Licensed tubes.....\$2.95  
 Wired and tested, extra..... 2.00  
 Special shielded Metal Can..... 1.75

**Duo-Wonder S.-W. Receiver**



**THIS** simple circuit will give beginners a splendid course in radio construction and operation. Uses '19 tube. Kit of Parts.....\$4.95  
 RCA Licensed tube..... .88  
 Wired, extra..... 1.00  
 Broadcast Coil..... .39

**REGENT 4 Tube A.C. S-W Receiver**



Complete Kit, with speaker.....\$11.50  
 Wired, extra..... 2.00  
 Modernistic Cabinet. 1.50  
 RCA Licensed tubes. 2.50  
 BRUNO Broadcast coil..... .79

**A COMPLETE** receiver with built-in dynamic speaker. Will tune from 15 to 550 meters. Tubes: 2-'58's, 1-'80 and 1-2A5 power pentode output.

**COVERS** the short-wave range from 15 to 550 meters. Power-tone is the first to use the new '79 tube. Extremely light in weight.

**"SCOUT" Portable AC-DC Receiver**



Complete Kit of Parts.....\$6.95  
 Carrying Case..... 1.46  
 RCA Licensed Tubes 2.25  
 Wired, extra..... 2.00

**TRY-MO RADIO CO., Inc.**  
 55 CORTLAND ST., Dept. S NEW YORK CITY

New 192 Page S.W. and P.A. Manual..... \$ .50

**A NEW "TRIPLE THREAT" RADIO TOOL**

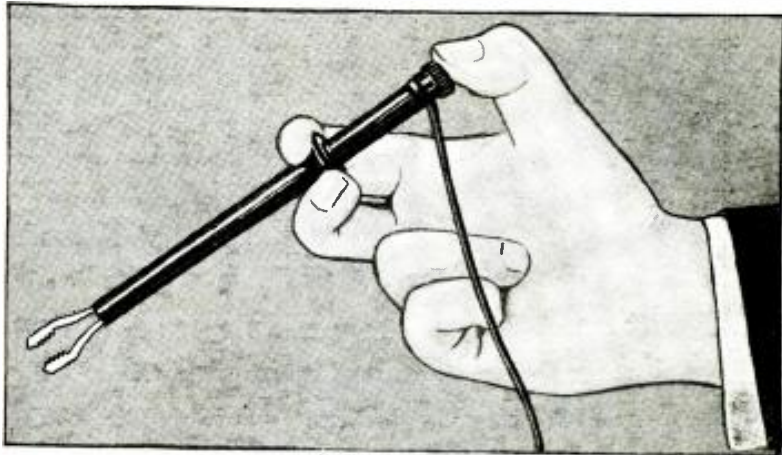

**THE SNAPPER**

No. 63 (Patent Pending)

**IT MAY BE USED AS**

1. A "Deep Sea" Electric Test Clip—Test contacts may be made with ease, deep in the recesses of a radio chassis with no danger of short circuits. You can reach spots you never thought of reaching before without tearing down the whole chassis.
2. An Electric Contact Prod—The clip jaws may be used to make quick Prod contacts. Or better still—clip one Snapper on the ground circuit and prod with another.
3. A Retriever—Use the Snapper to pick up small screws and nuts or other odds and ends that may accidentally be dropped into inaccessible places.

The long tube is of insulating material, and is fitted with spring contact jaws on the far end. The jaws are operated by a push of the thumb on the near end, while the first two fingers bear on the round fibre washer.

The cord or wire test lead is quickly and easily connected under the insulated knob binding post on the rear end. NOTE! Don't confuse the Snapper with mere retrievers. The Snapper is a retriever and test-prod only incidentally. It is primarily designed as an elongated, insulated electric test clip, and as such, is in a class by itself. It is designed to be the radio man's constant companion and his most useful tool.

**MUELLER ELECTRIC CO.**

Factory—1583 East 31st St., Cleveland, Ohio.  
 Registered Cable Address: "Mueller, Cleveland Ohio".  
 Pacific Coast Warehouse—50 Hawthorne St., San Francisco, Calif.  
 In Canada—W. H. Cooper & Co., 104 Adelaide St., E., Toronto.

**SEND \$1.00**  
 For Two Snappers Postpaid—2 in a Box—1 Red and 1 Black  
 (Snappers are furnished in Red and in Black. The use of one of each color is suggested to distinguish the leads.)  
**MUELLER ELECTRIC CO.**  
 1585 E. 31st Street, Cleveland, Ohio.  
 Gentlemen:  
 I enclose \$..... for which please send me..... Snappers (at 50c each net), Postpaid.  
 NAME.....  
 ADDRESS.....  
 My Jobber Is.....

### SUPERTONE BOOSTER IMPROVE YOUR SHORT WAVE RECEPTION



Can be added to any short-wave receiver from a 1 tube battery set to a 10 tube superhet. No rewiring of your set is necessary. Just connect directly to the Aerial and Ground post of your present receiver and you are all set for greatly improved reception on all bands. This booster has its own power supply which connects directly to the 110 volt A.C. or D.C. line. Just the pre-selector owners of two stage sets have been looking for to reduce image response to a minimum. Booster is housed in a beautiful crackle finished cabinet with linged top for easy changing of plug-in coils.

- Booster with coils ..... \$9.00
- Tubes—6D6 and 25Z5 ..... \$1.95
- Cabinet and Chassis ..... \$1.50
- Broadcast Model ..... \$8.50

**SUPERTONE**  
35 Hooper Street,

### SPECIAL SALE!

Superba Seven Tube Superheterodyne  
15-200 METERS

	Formerly	Now
Wired model in cabinet, complete with tubes and speaker .....	\$37.37	\$34.00
Wired chassis, complete with tubes and speaker .....	\$33.62	\$30.00
Kit form, complete with tubes, speaker and blue print .....	\$29.88	\$25.88

Supertone Band Spread Receiver  
15-200 METERS

Five tube set with separate power pack

	Formerly	Now
Wired set with coils .....	\$12.00	\$10.00
Power Pack .....	\$ 6.00	\$4.98
Tubes .....	\$ 3.50	\$3.00
Speaker .....	\$ 3.00	\$2.25

#### PLUG-IN COILS FOR SHORT WAVE

RECEIVERS—15-200 Meters

4 Prong A.C. ....	Set of Four	\$1.00
4 Prong Battery .....	" " "	\$1.00
6 Prong A.C. ....	" " "	\$1.25

**PRODUCTS CORP.**  
Dept. S-11, Brooklyn, N. Y.

### When to Listen In

By M. HARVEY GERNSBACH

#### Daylight Time

May we again advise listeners that daylight saving time ended for the U. S. and Canada on about the last Sunday in September, and that many American and Canadian stations shifted their schedules to one hour later in standard time.

#### Germany Plans More Stations

The German short wave station has a new unit in construction which will soon be on the air on any one of 6 different waves. Germany will then have 3 transmitters on simultaneously. The new wavelengths and calls to be used (in addition to the present waves and call letters) are:

- DJM, 6079 kc., 49.35 met.
- DJN, 9540 kc., 31.45 met.

(We have reports of these 2 waves already being used for testing.)

- DJO, 11795 kc., 25.43 met.
- DJP, 11855 kc., 25.31 met.
- DJQ, 15280 kc., 19.63 met.
- DJR, 15340 kc., 19.56 met.

The new transmitter will be used in conjunction with special directional antennae for increasing the area served by the present German S-W station. The new station will be in operation, it is hoped, by the end of this year. The power of the transmitter is 50 kw. During the past month the German station has operated 3 stations at once every evening (using the old wavelengths, however). From 5:30-9:15 p.m. every evening DJA, DJC and DJD have broadcasted simultaneously. It is apparent that the new plant will soon be in operation. Probably the new aerial arrangements have not been completed. For October the evening broadcast to North America will probably take place on DJD and DJC from about 6:30-11 p.m. The other transmissions from the German stations are to be found in the station list.

#### Lima, Peru

There is a new station in Lima, Peru, which broadcasts nearly every evening. The wave used is 38.36 or 31.0 met. There seems to be a conflict about the call letters. One report gives OCN and another OA4AC. It is possible that both are correct. OA4AC is probably the call employed when the station is engaged in amateur traffic, while OCN is used for broadcast work.

#### Australia

VK2ME at Sydney (9500 kc.) broadcasts every Sunday in October from 12:30-2:30, 4:30-8:30 and 9:30-11:30 (all a.m.); in November the schedule is: Sundays, 1-3, 4:30-8:30, and 9-11 (all a.m.).

VK3LR, at Melbourne on 9580 kc., broadcasts daily except Sunday from 3-8 a.m.

#### Verifications

May we remind listeners that the RCA stations at Rocky Point, N. Y.; New Brunswick, N. J.; Bolinas, Cal., and Kahuku, Hawaii, will not verify reception reports. In accordance with federal laws they will send the writer a polite letter quoting the law as regards the maintenance of secrecy concerning any communications overheard by the listener and stating that it is therefore impossible to verify. The American Tel. & Tel. Co. stations at Lawrenceville and Ocean Gate, N. J.; Hialeah, Fla.; and Dixon, Cal., follow the same procedure. It is therefore useless to write to these stations for a specific verification.

#### Japan

In addition to the JYM mentioned last month there is a whole group of JV- stations at Nazaki, Japan. These stations are primarily for commercial service to all parts of the world but are used for broadcast service frequently. For checking purposes we list all the JV's and their wavelengths.

- JVA—18910 kc.—15.86 met.—Service to Europe.
- JVB—18190 kc.—16.49 met.—Service to D.E.I. and Phil. Is.

## A new service! on SHORT-WAVE KITS

Each month our technical staff will choose from this magazine those receivers which, in its expert opinion, are the best all around sets. These receivers will then be worked into complete kits which we will present to you each month on this page. The idea is the same as the "Book-of-the-Month" club, where the literary books published during a single month are reviewed by a group of competent judges and only the best submitted to its members. In this manner you are assured of getting only "the cream of the crop." The same is true of our new short-wave kit service.

Each month, therefore, will find listed on this page a new series of carefully selected kits. Each kit will be accompanied by the magazine in which its article appeared. Prices will be skinned to the bone, bringing these selected kits within the reach of all short-wave fans. These prices, however, will be guaranteed for only one month. After that time they become subject to change without notice, depending upon general market conditions.

### POPULAR SHORT-WAVE SET KITS

- No. E2141 2-tube 12,500 mile Doerle Receiver Kit, less tubes. Wt. 5 lbs. YOUR PRICE .... \$8.71
- No. E2144 3-Tube 2-Volt Doerle Signal Gripper Kit, less tubes. Wt. 7 lbs. YOUR PRICE .... \$11.51
- No. E2175 Electrified 2-Tube 12,500 Mile Doerle Receiver Kit, less tubes. Wt. 5 lbs. YOUR PRICE .... \$9.24
- No. E2178 Electrified 3-Tube Doerle Signal Gripper Kit, less tubes. Wt. 7 lbs. YOUR PRICE .. \$13.74
- No. E2147 Oscillodyne 1-Tube Wonder Set Kit, less tubes. Wt. 4 lbs. YOUR PRICE .... \$6.34
- No. E308 Famous 19 Unimount Twinplex Kit, including single headphone and plug-in coil, less tube. Ship. wt. 4 lbs. YOUR PRICE .... \$49.94

### The "MONOCOIL 4" — No Plug-in Coils —

In construction and operation, this receiver is very similar to the "Mono-Coil 2" described at the left. However, having an additional tube as well as an additional tuned circuit, it has lots more "wallop."

No plug-in coils of any kind are used. And furthermore, instead of crowding the interesting international broadcast band on only a few scale divisions of the dial (as is done with most of the ordinary short-wave receivers), this set takes that same band and spreads it over the entire scale of the tuning dial making for simple, pleasant tuning.

This receiver will work anywhere that 110 volts is available—110 volts either A.C. or D.C., 25 or 60 cycles.

The chassis is drilled for tube sockets only in order to keep the price down. It is made of soft aluminum and is very easily drilled and machined. Add \$1.95 to price if completely drilled chassis is desired.

Receiver measures 9 1/2" wide by 8" deep by 7" high. Ship. wt. 12 lbs.

No. E-502 Mono-coil 3 Short Wave Receiver Kit, less tubes. YOUR PRICE ..... \$17.20

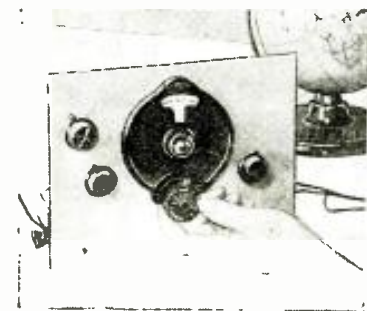

### The "MONOCOIL 2" Featured in Aug. Short Wave Craft — No Plug-in Coils —

The ultimate in short wave radio has arrived. The elimination of the "immortal" Plug-in coil system. The "Mono-coil 2" not only does this but goes further. Its coil and switch arrangement is so simply constructed that there are practically no I.P. losses.

It does not have the tremendous band coverage of from 15 to 200 meters but rather specializes in the foreign broadcast band, of from 19 to 45 meters and naturally when a receiver is constructed in such a highly specialized manner, IT MUST BE GOOD! A mere turn of the switch on the front panel will instantly change the circuit to receive either the 19 to 25, 25 to 33, or 43 meter bands.

The kit includes everything to construct the set. Only the tube socket holes are drilled in the chassis to keep the cost down. The chassis is made of soft aluminum, and easily drilled and machined. Add \$1.95 to price of kit if completely drilled chassis is desired.

The receiver must be operated with a power pack. Any good pack delivering 2.5 volts for the filaments and 250 vts. for the plates will do. The set measures 9-in. wide by 5-in. deep by 7-in. high. Shipping weight 7 lbs.

No. E-501 "Mono-Coil 2" Short Wave Receiver Kit, less tubes. YOUR PRICE ..... \$10.90

### The ADVANCED "19" TWINPLEX

Featured in Sept. Short Wave Craft  
2 TUBES GIVES 3-TUBE PERFORMANCE

This receiver is a 2-volt job that requires but two No. 6 dry cells for the filaments and three 45 volt "B" batteries for the plate supply. A set of these batteries will last a long time even with frequent use—that's how economical it is to operate this Twinplex receiver.

The kit includes everything necessary to build the receiver. The chassis is drilled only for socket holes in order to cut down the cost of the kit. It is made of aluminum and is easily drilled and machined. Add \$1.95 if you desire to have a completely drilled chassis.

Tubes: 1-19 and 1-34. Shipping weight, 12 lbs. No. E-500 Advanced "19" Twinplex Short Wave Kit, less tubes. Shipping wt. 12 lbs. YOUR PRICE ..... \$11.70

**RADIO TRADING CO.**  
101A Hudson St., N. Y. C.

### Featured in Sept. Short Wave Craft





- JVC—16050 kc.—18.69 met.—Inland and to Hongkong.
- JVD—15860 kc.—18.91 met.—Inland and to China.
- JVE—15660 kc.—19.16 met.—
- \*JVF—15620 kc.—19.21 met.—Inland and to Manchuria.
- JVG—14910 kc.—20.12 met.—Europe.
- JVH—14600 kc.—20.55 met.—Europe.
- ....—14540 kc.—20.63 met.—U. S. A.
- JVI—13560 kc.—22.12 met.—D. E. I. (Dutch East Indies.)
- ....—12275 kc.—24.44 met.—Hongkong.
- ....—12155 kc.—24.68 met.—Inland and Hongkong.
- ....—12020 kc.—24.96 met.—China.
- JVL—11660 kc.—25.73 met.—
- \*JVM—10740 kc.—27.93 met.—
- \*JVN—10660 kc.—28.14 met.—U. S. A.
- JVO—10375 kc.—28.92 met.—Manchuria.
- JVP—7510 kc.—39.95 met.—Europe.
- JVQ—7470 kc.—40.16 met.—D. E. I.
- JVR—7300 kc.—40.60 met.—Inland and Hongkong.
- JVS—6990 kc.—42.92 met.—Inland and China.
- JVT—6750 kc.—44.44 met.—U. S. A.
- JVU—5790 kc.—51.81 met.—Inland and Manchuria.
- JVV—5730 kc.—52.36 met.—Inland.

Those marked with an asterisk (\*) have been reported frequently.

**Bombay**

The new Bombay station VUB is operating on Wednesday and Saturday from 11 a.m.-12:30 p.m. The transmitter, despite all reports otherwise, is definitely located at Kirkee (not Durkee), India, 120 miles from Bombay.

**Rome**

12RO at Rome, as listeners have no doubt observed, has not been on the air since early June. It is reported that the station is being rebuilt.

**PHI**

PHI at Huizen, Holland, is now back on its winter wave of 25.57 met. or 11730 kc.

**W2XE**

The schedule of W2XE in N. Y. C. for the winter is 11 a.m.-1 p.m. on 15270 kc., 3-5 p.m. on 11830 kc. and 6-11 p.m. on 6120 kc.

**W3XAL**

The schedule of W3XAL is as follows: Daily 10 a.m.-4 p.m. on 17780 kc. and on Monday, Wednesday and Saturday from 4:30 p.m.-1 a.m. on 6100 kc.

**W8XAL**

W8XAL at Cincinnati, Ohio (6060 kc.), broadcasts from 7:30 a.m. to 8 p.m. and from 11 p.m. till 2 or 3 a.m. daily. When Daventry, England, returns to the 49 meter band on GSA (6050 kc.) this fall from 6-8 p.m. W8XAL will probably repeat its courteous gesture of last winter and sign off at 6 p.m. to enable American listeners to enjoy good reception of GSA.

The operators of W8XAL are to be congratulated for their consideration.

**High Fidelity Stations**

By September 15 the several new experimental broadcast stations should be on the air in the U. S. A. These stations are authorized to transmit a frequency range twice as great as the ordinary long wave broadcast stations in this country. The object is for experimental work in high fidelity transmissions.

Although these stations are not really S-W stations (they operate just below the regular broadcast band from 1530-1590 kc.) they are interesting because the average all wave or short wave receiver will pick them up. All are rated for 1 kw. power.

- W6XAI—Bakersfield, Cal., 1550 kc., 193.5 meters.
- W9XBY—Kansas City, Mo., 1530 kc., 196.1 meters.
- W2XR—Long Island City, N. Y., 1550 kc., 193.5 meters.
- W1XBS—Waterbury, Conn., 1530 kc., 196.1 meters.

**UNCLE DAVE'S RADIO SHACK**

WE AMATEUR SUPPLY BUYERS TRY TO GET ONLY THE BEST THAT MONEY CAN BUY FOR YOU!

WE STAND BEHIND EVERY RADIO OPERATOR WITH OUR UNCONDITIONAL GUARANTEE. SHIP EVERYWHERE—24 HOUR SERVICE.

WE BUY—SELL AND TRADE IN HAM RADIO SUPPLIES.

**356 BROADWAY, ALBANY, N. Y., U. S. A.**

**Announcing the New Peerless 30 Watt Phone-CW Transmitter!**

Drop us a card for detailed description and low prices.

**PEERLESS SENIOR TRANSMITTER**, compl. with heavy power supply, two 245 tubes, an 83 tube, milliammeter, approx. 10 watts output, wired and tested, special ..... \$16.25

**PEERLESS RADIOPHONE TRANSMITTER**, compl. with microphone, tubes, milliammeter, ready to plug into 110 v. 60 cycle AC supply.....\$36.50  
Above xmitter, crystal control with xtal ground to your frequency in 160 meter band.....\$41.25

**PEERLESS JUNIOR TRANSMITTER**, compl. with tubes, power supply, 40-meter coils, wired and tested, ONLY .....\$10.95

**PRECISION APPARATUS**

PEERLESS MONITOR .....	\$9.35
PEERLESS WAVEMETER .....	6.25
PEERLESS CRYSTAL OVEN .....	8.25
PEERLESS CRYSTAL OVEN (less crystal) .....	6.50

Write in for descriptive bulletins on above precision apparatus.

**CRYSTALS**

Peerless Precision crystals, ground anywhere in the 80 or 160 meter band guaranteed accuracy of 1 of 1%. Complete with molded bakelite dust-proof adjustable holder. ONLY .....\$2.75

A crystal complete with Peerless Precision type plug-in commercial crystal holder, each.....\$3.60

7000kc. PEERLESS crystal.....1.60

Finished Oscillating blank.....5.50

Unfinished blank, each.....1.00

Peerless molded bakelite adjustable dustproof crystal holder, each......74

Same type, but plug-in, each.....1.05

Peerless Commercial plug-in precision crystal holder, each.....1.29

**HAMS! TAKE NOTICE!**

The biggest buy in the country on Weston slightly used but perfect model 301 milliammeters, ranges 0-5, 10, 25, 50, 100, 150, 200, 250, 300, 500 millis. All recalibrated with new scales. EACH...\$3.69

Thousands of other type meters in stock, including laboratory, ham, and experimental models. Drop us a card for lowest quotations.

**WE JUST RECEIVED ANOTHER BATCH OF CG-1162 NAVY 5-Wattors**, so rush your orders in today—SPECIAL—While they last—\$1.00.

**IF YOU HAVE NOT ALREADY RECEIVED OUR RED HOT BULLETINS, RUSH YOUR REQUEST IN TO US—HERE ARE OUR LATEST HOT BUYS ON THE NEWEST PEERLESS ROUND-THE-WORLD RECEIVERS!**

Peerless 1-tube Blackhawk.....	\$3.89	\$4.89
Peerless 2-tube Junior Receiver.....	4.75	6.15
Peerless 2-tube Loudspeaker Receiver.....	7.95	8.95
Peerless 3-tube Professional Receiver.....	9.50	10.95
Peerless 4-tube AC-DC Receiver (new tubes equiv. to 8 ordinary tubes).....	21.50	24.50

Let us also quote you on the latest National and Hammarlund Receivers.

**CABLE ADDRESS: "UNCLEDAYE" WRITE IN FOR OUR NEW HAM CATALOG—JUST OFF THE PRESS!**

**UNCLE DAVE'S RADIO SHACK**

356 BROADWAY FOREIGN TRADE SOLICITED ALBANY, N. Y.

Long Distance Phone: 4-5746

**SLIDE RULES . . .**

**Midget 5 in 1 Circular Type:**

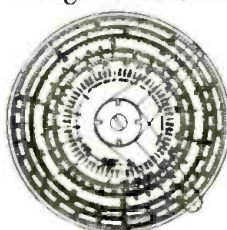

Metal 4" Dia.  
Price \$1.50  
Case 50c extra

1.23° = √50.41 = ?  
1.24° = ?  
Tan 8°5' = ?  
Cot 79 1/2° = ?  
4 1/4 × 3/8 = ?  
Log 56.25 = ?  
6% of 145.9 = ?  
5.16 - 3 1/4 + 1.78 = ?

Solve easily all these and dozens of other mathematical problems without pencil and paper—by means of the Midget Slide Rule. This rule solves any problem in multiplication, division, addition, subtraction, and proportion. It also gives roots and powers of numbers. The "Trig" scales give the sines, cosines, tangents and cotangents of all angles; also logs of numbers. Adds and subtracts fractions. Approved by colleges.

10" Dia., 27" Scale "Special" Rule, \$3.00.  
Multiples and Divides, but has no "Trig" Scales.

**RADIO Slide Rule—Short Wave Type**

Price \$1.00 Prepaid

Printed on white bristol board: Size 8 1/2" x 11". Every short wave and radio student must have this inductance, capacity, and "coil-dimension" slide rule. It will answer such questions as: What is inductance of coil one inch in diameter, winding two inches long and having 30 turns per inch? What winding length of No. 21 S. C. wire must be put on a form two inches in diameter, to obtain an inductance of 100 microhenries? To what frequency and wavelength will 35 microhenry coil tune with a 50 mfd. condenser?



**NEW! "OHM'S LAW" CALCULATOR**  
Solves All Problems of Voltage, Current and Resistance. Price.....\$1.00 Prepaid

**DATAPRINT CO., Box 322, Ramsey, N. J.**



**Prices Down Buy Now!**

**TYPE BC-3 MOUNTED CRYSTALS**

Mc Band	Exact Freq.	± 1Kc	± 5Kc	± 10Kc
7.0, 3.5	\$7.50	\$5.90	\$4.90	\$3.95
1.7	8.40	6.80	5.80	4.80

\*Or your choice from distributor's stock. Crystals manufactured between 20 Kcs and 15 Mcs. Prices on request.

Biley Crystals are sold at all progressive distributors of amateur equipment and manufactured under NRA.

**BLILEY ELECTRIC COMPANY**  
236 Union Station Bldg. Erie, Pa.

**GET the WORLD ON THIS FAMOUS International SW3A**

World Wide Short Wave Receiver



EXCELS in performance, selectivity and volume.

**ALL ELECTRIC WITH SPEAKER COMPLETELY ASSEMBLED**

Kit including coils to cover from 14-220 meters. BUILT IN POWER SUPPLY.

SPEAKER and large diagram.....\$6.75  
Extra for Wiring.....\$1.75  
Broadcast Band Coil, 200-500Mc......75  
Set of matched AIRCRAFT'S Tubes.....2.25

**EXPERIMENTAL RADIO LABS**  
168 Washington St. Dept. SWC-11 New York, N. Y.



# ★ TWO SHORT WAVE STARS ★



Alan International

T.R.F. Circuit AC-DC Power Supply  
Front Panel Plug-In Coils  
Available for 110 v. A.C.—D.C. 8, W. 15—200 meters, also 220 v. A.C.—D.C. 2 and 6 v. battery operation, four tubes 1-6F7, 1-7A, 1A3, 1 25Z5. Completely shielded in black crackle, hinged cover, metal cabinet.  
Complete including 4 pairs of coils, 15-200m **\$24.95**  
Set Arcturus tubes..... **4.95**  
Complete Kit with Blueprints..... **21.25**

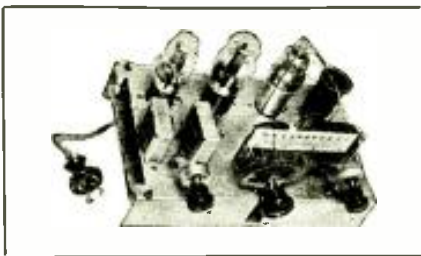

PRIZEWINNER

A.C.-D.C. S.W. (15 to 200 meters)  
Completely self powered, latest type 77-43 and 25Z5 Tubes. Provision for Head Phones and speaker. Complete, less tubes, in rich crackle-finish cabinet. Assembled, wired, tested, ready to plug in, including four coils..... **\$12.95**  
Kit of RCA or Arcturus Tubes to match.... **3.75**  
Complete Kit of parts, including 4 coils.... **10.55**

Write for Free Catalog and Short Wave List.

**ALAN RADIO CORP.,**  
83 CORTLANDT ST. Dept. 118C N. Y. CITY  
Save time on Western shipments by buying from our Pacific Coast Branch,  
1028 SOUTH OLIVE ST., LOS ANGELES, CALIF.

## Broadcast Pick Up Stations

Many broadcast stations arrange "on the spot" broadcasts from out-of-the-way places by using portable S-W transmitters erected at the point of interest. These portable transmitters can operate on any of the following waves: 1606, 1646, 1652, 2020, 2060, 2090, 2102, 2190, 2760, 2790 or 2830 kc. In meters, 186.8, 182.2, 181.6, 148.5, 145.6, 143.5, 142.7, 137, 108.7, 107.5, and 106 meters.

## Java

There are several new Javanese stations in operation. All broadcast entertainment. YDA is in Bandoeng on 49.02 meters; YDB in Sourabaya is on 49.67 meters; YDB2 in Semarang is on 68.65 meters. In Batavia there are 2 stations: PK1KK on 62 meters and PK1AK on 40 meters. PK1AK works on Monday, Wednesday and Friday from 4:30-6:30 a.m. PK1KK works on Monday, Wednesday and Saturday from 7:30-9:30 a.m. Another station in Sourabaya is PK3GH on 60 meters. This station operates daily from 4:30-5:30 a.m. A station of unknown call is located at Lampur and operates on 47 meters each Monday, Tuesday and Saturday from 4:30-7:30 a.m.

Java time is 12 hours and 20 minutes ahead of Eastern Standard.

PK1WK at Bandoeng is now up on 87.96 meters from 4:30-5:30 a.m.

## Schenectady

The winter schedule for W2XAF and W2XAD, which goes into effect on Sept. 30, follows: W2XAD, daily 2:30-3:30 p.m. on 19.56 meters; W2XAF (31.48 met.) daily 7:25-11 p.m. (Sundays till 12 midnight.)

## Winnipeg

The winter schedule of CJRO and CJRN (48.78 and 25.47 met.) is as follows: Daily, except Sunday 8 p.m.-12 midnight. Sunday 8-10:30 p.m.

## Daventry

On Oct. 7th the following schedule will go into effect for the Daventry transmissions. Trans. 1:

On Oct. 7 the following schedule goes into effect for the British stations: Trans. 1—2:15-4:15 a.m. on GSD and GSB; Trans. 2—6:9:00 a.m. (Sun., 6:30-9:00 a. m.) on GSG and either GSF or GSE. Trans. 3—9:15-10:45 a.m. on GSF and GSE; 10:45 a.m.-12:45 p.m. on GSE and GSB. Trans. 4—1-4 p.m. on GSD and GSB; 4-5:45 p.m. on GSB and either GSD or GSA. Trans. 5—6-7 p.m. on GSC and either GSD or GSA; 7-8 p.m. on GSC and GSA.  
(All time quoted is Eastern Standard)



# The Breakers

ATLANTIC CITY, NEW JERSEY  
On the Boardwalk



SITUATED DIRECTLY ON THE OCEANFRONT AND CONVENIENT TO ALL PIERS AND AMUSEMENTS

**\$6 WITH MEALS** Daily WITHOUT MEALS **\$3**  
PRIVATE BATH Per Person PRIVATE BATH

Hot and Cold Sea Water in all Baths

EXCELLENT FOOD GARAGE ATTACHED

## RADIO OPERATING RADIO SERVICING—



Prepare for the new Government Radio Operating License examinations. Radio Amateur Telegraph and Telephone. Also Amateur Code. Day and Evening Classes. Resident Courses.

Write for Booklet

New York YMCA Schools  
6 West 64th Street New York City



## HAVE YOU A HEADACHE

trying to find out where you can obtain certain parts that you need for your short wave radio or your station? Stop worrying.

This is the "House of a Million Parts", where you can obtain the most up-to-date or any obsolete part.

Send us a list of your needs and we will quote our lowest prices.

Interesting literature mailed free.

LEOTONE RADIO CO.

63 DEY STREET Dept. S-11 NEW YORK CITY

## Best Aerial for "Europeans"

(Continued from page 398)

Asiatic reception, we run it from S.E. to N.W. due to the directional effect of the doublet being crosswise, or at right-angles to the wire.

Using this aerial system and a National FB7, plus two stages of added T.R.F. (tuned radio frequency) we can absolutely guarantee to let visitors hear England, France, Germany, Spain, and Italy daily, while Japan, China, and Australia "roll in sweet"!

It will be found that each set of coils cover only about 10 to 15 meters, but since the antenna is a complete circuit in itself, you can insert a 9 turn coil in one side and a 2 or 5 turn coil in the other side, and thereby cover that portion of the receiver dialing not covered effectively by matched coils. On some frequencies a single coil in one side with the other side vacant, will be effective; you are then coupling the two ends of the doublet through ground capacity of the .00035 mf. condensers only. Tuning will be very critical but the noise level will be raised to a noticeable extent. At this time the use of .00035 mf. condensers will be more effective. Leave them open when using matched coils in both sides.

## SPECIAL FOR THIS MONTH ONLY.

Send \$1.00 (\$1.25 Canada and foreign) and we will send you SHORT WAVE CRAFT for Eight months. DO IT NOW.

**SHORT WAVE CRAFT**  
99-101 Hudson Street New York

- ALUMINUM PANELS ■
- 16 Gauge .....7x12, 28c; 7x14, 32c
- 5/64 Inch or 13 Gauge.....7x10, 29c
- 7x12, 3 1/2x14, 4 1/2x18, 4 9/16x24, 6 5/8
- These panels are a special lot at the above prices.
- Longer and wider at correspondingly low prices.
- Add postage on 2 lbs. for each. We do not publish a catalogue. Estimates gladly furnished on request.
- Radio parts for over 10 years.
- **BLAN THE RADIO MAN, Inc.**
- 177 Greenwich St. Dept. S New York, N. Y.



## WE HAVE DECIDED TO GO ALL THE WAY

**Comparison of Dielectrics**

Insulator	Factor	Per Factor
Transparent Fused Quartz	.02%	at 100 kc.
VICTRON AA	.02%	at 877 kc.
Ultra Steatite	.09%	at 2000 kc.
Steatite	.18%	at 825 kc.
Isolanite	185%	frequency not given
Mycalex	.2%	at 100 kc.
Electrical Glass	.4%	at 100 kc.
Porcelain	.7%	at 100 kc.
Bakelite Grade XX	3.6%	frequency not given

\* Taken from VICTRON literature distributed at 1934 Annual I.R.E. Convention in Philadelphia. To make our coil forms both an outstanding value in price and in efficiency we gave consideration to and announced coil forms in low-loss Bakelite. But because of the sensational insulating qualities of VICTRON "AA" we have decided to put this unusual material in the first (highest frequency) coil of all of our S.W. coil sets. Not only are they wound on VICTRON but the windings are also fixed in place with Liquid VICTRON for maintaining its extremely low power factor dielectric constant—besides producing a tough, tenacious and moistureproof film of extremely high surface resistivity. Some coating mediums used in radio increase the coil's distributed capacitance six-fold and have a 40% power factor while VICTRON'S power factor is only 0.0002 and its dielectric constant under 3 so that the extreme efficiency of our VICTRON coils will not be wasted we have developed VICTRON tuning condensers, sockets, coil selectors and chokes as shown below:



Here is the Na-Aid Condenser insulated with VICTRON "AA" whose p.f. at r.f. is only 0.0002. Note these outstanding features: silver pressure contact on rotor. No grease or film or oxide skin as in bearing contacts. Self centering, self tightening cone bearing cannot loosen or produce noise. Minimized metal gives extremely low minimum capacity. Most practically shaped plates for station separation. Soldered brass plates precision spaced. 140 mmf. max. cap. Universal mounting. Two double solder tabs. No. C-140 Na-Aid VICTRON "AA" insulated \$1.50 S.W. Condenser. List price.....



Here is the new Na-Aid VICTRON insulated R.F. Choke Coil, designed especially for use at the ultra high frequencies where losses are so all-important. Five tapered universal wound plates on a VICTRON form which can be rigidly mounted and connected, thus preventing wobbly signals from vibration. Small pie at "hot" plate end of choke for reduced capacitance. Why not use this choke in all applications and enjoy its greater efficiency. D.C. resistance 40 ohms. Inductance 25µm.h. No. 702R—Na-Aid VICTRON R.F. Choke. \$ .70 List Price.....



Here are the VICTRON "AA" Sockets. Contacts are out in air, touching VICTRON only where mounted. Ultra low-loss. Mounts easily with use of hand-drill. Jack-top binding posts. Overhanging solder tabs for below chassis wiring. Nos. 494V, 495V, 496V, 497V and 497VA 4, 5, 6, 7 and small 7 contact respectively. List price... \$1.00



New 700 COIL SELECTOR takes any four 4, 5 and 6 prong coils for selection by turning knob. Mounted on chassis and panel. Modernizes old sets—eliminates handling and storing coils. Simple—compact—rugged—highly efficient—reliable self cleaning pressure contacts. List price without coils.....\$3.50 No. 700V NA-AID VICTRON "AA" Insulated Coil Selector.....List Price \$7.50 No. 700P PL Complete Coupling Hardware for gauging No. 700 Coil Selectors in tandem.....List price 25c

All coils listed below are boxed with diagrams and directions and use 140 mmf. size condensers.

- Set of 4 S.W. Coils with one VICTRON "AA" 13-200 meters tuning range.
- 704SWS 4-pin Coils.....List \$2.00 set
- 705SWS 5-pin Coils.....List \$2.50 set
- 706SWS 6-pin Coils.....List \$3.50 set
- Set of 2 Coils for 100-550 meters.
- 704BCS 4-pin Coils.....List \$1.50 set
- 705BCS 5-pin Coils.....List \$1.75 set
- 706BCS 6-pin Coils.....List \$2.00 set
- Band Spreading Coils with ceramic padding condenser mounted on each coil. Simplifies tuning. Spreads stations.
- 705SWB-20-40-80-160 m. Amateur Coils.
- 705SWBC-19-25-31-49 m. S.W. R.C. Coils. List price \$4.00 per set. \$1.00 per coil.
- Long Wave Coils for S.W. Sets using 140 mmf. and 4-prong Coils.
- 704LW1 450-900 meters.....List \$1.00
- 704LW2 940-2000 meters.....List \$1.00
- 704LWS Set of 2 Coils.....List \$2.00 set

NA-AID VICTRON "AA" COIL FORMS  
 704V 4-pin.....List \$1.00 705V 5-pin.....List \$1.00  
 706V 6-pin.....List \$1.00 707V 7-pin.....List \$1.00  
 708V 8-pin.....List \$1.00 709V 9-pin.....List \$1.00

Send for Complete Catalog and State Supplier  
**ALDEN PRODUCTS CO.**  
 Dept. SW 11 715 Center St. BROCKTON, MASS.

## Improving the Victor Two-Tube Super-Het

(Continued from page 395)

plate voltage detunes the circuit more than is permissible.

This was very impressively brought to light one day while comparing the performance of the original super-het with a well-known factory-made three-tube battery model. The battery model was running circles around the Victor, that day, both in ease of tuning and freedom from fading; operation being in the 20 meter band. The Victor was all A.C. operated at the time. Changing over to "B" battery plate-supply the results were just about 100 per cent the reverse, in fact the Victor worked so much smoother and better, that the "B" eliminator was very carefully checked for a defect. A check of the line voltage showed variations of 5 to 15 volts which would give variations of as high as 35 volts to the oscillator plate. Since we could not "steady" the line voltage, any remedy used would have to be applied to the oscillator.

### Cathode Coil in Oscillator Circuit

A simple variation of electron coupling was finally adopted, and while it may be considered a "trick" circuit by some, it certainly has proven its worth in operation from unsteady A.C. lines. The remedy is as follows. Remove the tickler from the plate circuit of the 6A7 and place it directly in the cathode circuit of the same tube. Connect it in right next to the tube, in the lead that runs from cathode to the 250 ohm resistor and by-pass condensers. The lead which formerly ran to P1 of the tickler is now run directly to "B" positive. Be sure the circuit oscillates after the changes are made, and in case it does not, reverse the tickler leads at the coil, as the correct polarity must be maintained.

### "Band-Spread" Dial Added

The next improvement was the addition of a band-spread dial, a virtual necessity for amateur work. In the picture, it is the right-hand dial, the center knob at the top is the detector trimmer condenser and the knob between the two dials at the bottom, the volume control. The Band-spread condenser used is a midget made over into a double-section affair, having a common rotor and two stators. Each stator section contains three plates, this giving about 65 degrees spread on the 160 meter phone band. Two plates per stator will give about 90 degrees spread, if one cares for that much. In hooking up the band-spread condenser, the rotor is grounded, one stator connects to the main detector tuning condenser stator, the other midget stator goes to the oscillator condenser stator.

To use the band-spread, set the right-hand dial at about 10. Tune the set as usual to the very high frequency edge of the band being used. From now on, all tuning over this band is done with the band-spread dial, stations formerly hard to tune in being brought in with a new sense and ease of control. A slight adjustment of the detector trimmer condenser may be needed as we tune from one end of the band to the other.

In most locations a certain level of background noise is encountered and any receiver using a tone control can usually reduce this noise to a satisfactory level, for general reception. However, the application of the step capacity or resistor and capacity method of tone control has the disadvantage of also reducing signal strength along with the noise. Summer static, plus a more or less constant background-noise level, made the tone control a much wanted feature. It was felt advisable to add one stage of audio, with the tone control, to give us better reception with less noise, plus the added advantage of more over-all "gain" for the receiver. A type 37 tube is used, resistance coupled to the 6F7, together with



## HAMMARLUND High-Efficiency Low-Loss S-W COILS At a New Low Price

WOUND on forms molded from the remarkable new Hammarlund Low-Loss "XP-53" Dielectric, these coils set a new standard of efficiency. Rugged and free from loss-causing artificial coloring. Ribbed for air-spacing. Easy flange grips with "meter-index" inserts. Low-loss, silver-plated secondaries on 10-to-75-meter coils.

- 4 four-prong coils (15-220 meters), \$3.00 list
- 4 six-prong coils (15-220 meters), \$3.75 list

Other coils available for 10-to-550 meters. "XP-53" Coil Forms, 35c each list.

## Air-Tuned Trimming and Padding CONDENSER



This new low-loss condenser has air-dielectric, brass plates and Isolanite insulation. It may be attached to a special molded shelf inside Hammarlund "XP-53" Coils and Coil Forms for I.F. tuning and padding or trimming oscillator and other circuits. Four capacities: 25, 50, 75 and 100 mmf. List price, \$1.30, \$1.50, \$1.70 and \$1.90 each, respectively.

**HAMMARLUND MFG. CO.,**  
 424-438 West 33rd St., New York.

—Check here and attach 10c for 16-page Hammarlund 1935 Short-Wave Manual illustrating and describing most popular S-W circuits of past year, with schematic and picture diagrams and parts lists.  
 —Check here for FREE information on XP-53 Coil Forms and Coils.  
 —Check here for FREE General Catalog.

Name .....

Address .....

..... SW-11



# 100% Short Wave Book and it's

# FREE!

Exclusively Short-Waves

From Beginning To End  
52 PAGES 50 HOOK-UPS 500 ILLUSTRATIONS  
A Real Text Book On Short-Waves

ANOTHER GREAT EVENT! This special edition of our famous Treatise is exclusively short-wave from beginning to end. Packed between its two covers is a wealth of information covering the entire short-wave field. Every word in it is new.

This Short-Wave Treatise contains 52 solid pages of useful short-wave information, diagrams, illustrations, short-wave kinks and real live short-wave radio merchandise. It contains more valuable short-wave radio information—more real live "meat"—than many text books on the subject. Special attention has been given to the short-wave beginner. Numerous articles are devoted entirely to his interest. Yet, we have not forgotten all you of-timers. There is plenty of real "dope" for you too.

**PARTIAL LIST OF CONTENTS**

Getting Started in Short-Waves—Helpful Short-Wave Kinks—Principles Of Short-Wave Converter Operation—Bandspreading Explained—How to Build the "19" Unimount Twinplex For Less Than \$5.00—How to Tune For Foreign Short-Wave Stations—How to "Bandspread" the 2-Tube Electrified Duerle Set—How to Build a 5 and 10 Meter Phone and C.W. Push-Pull Transmitter—How to Build a Medium Power Transmitter Using the New 203-A Tubes—All About the New Short-Wave Transmitting and Receiving Antennas—Notes On Short-Wave Operation (Effect of Time of Day and Season of Year on Short-Wave Reception)—Complete Up-To-Date Characteristics of Transmitting Tubes, etc., etc.

Enclose five cents coin or U. S. stamps for postage—Treatise sent by return mail. PRINT NAME AND ADDRESS CLEARLY.

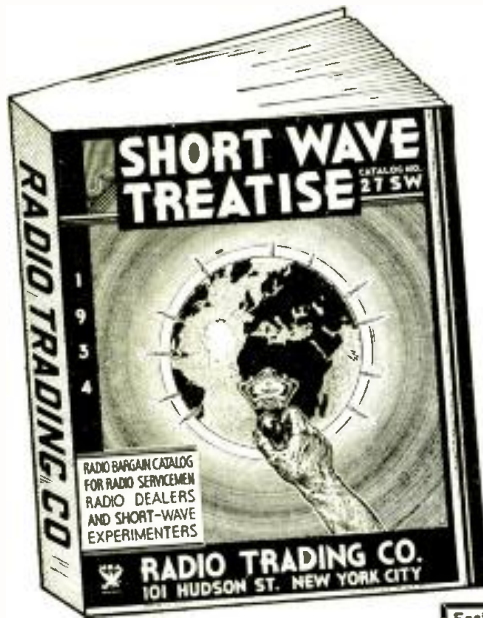

## WRITE TO-DAY

**RADIO TRADING CO.**  
101A Hudson St. New York City

## "SIGNAL HOP"

Beyond Your Fondest Hopes with  
**PEAK Pre-Selector and Pre-Amplifier**

With High Gain Regenerative Feature  
Here's the last word in Pre-amplification employing 2 tuned stages of high gain 58 type tubes. Hundreds of tests have proved that signals of R3 to R5 audibility can be consistently boosted to R9 and R9+. Besides tremendous signal gain, PEAK gives increased sensitivity; ABSOLUTE REJECTION OF IMAGE OR REPEAT SPOTS; reduction of background noise and increased selectivity.

Operates with ANY S.W. or All-Wave receiver. Comes complete with 3 SETS OF BUILT IN COILS (NONE TO PLUG IN) covering all frequencies with overlap from 14-200 M. Other features include airplane type dial, smooth regeneration,

automatic change-over switch, self-contained filament supply, etc. Every PEAK Pre-Selector sold with an UNCONDITIONAL GUARANTEE of satisfaction or your money back after 15 days' trial. Hams and Short Wave fans don't delay getting ALL the facts today!



110-120 V. A.C. 50-60 cycle.  
**ATTENTION**

The price of the PEAK Pre-Selector is \$33 complete, less tubes. 40% discount is extended to Servicemen, Amateurs, Experimenters. Send your order direct to us for quick delivery or order through your jobber or favorite Mail Order House.

**EASTERN RADIO SPECIALTY CO.**  
Manufacturers of PEAK PRODUCTS  
113 East 168th Street Dept. SC114 New York, N. Y.

# Announcing Amazing Typewriter Bargain

New Remington Portable only 10c a Day

**10-DAY FREE TRIAL OFFER**

Only 10c a day buys this latest model Remington Portable!

Not a used typewriter. Not a rebuilt machine. It's a brand new, regulation Remington typewriter. Simple to operate, yet does the finest work. Full set of keys with large and small letters.

Try this typewriter in your home or office on our 10-day FREE TRIAL OFFER. If at the end of 10 days you do not agree that this Remington is the finest portable at any price, you can return it at our expense. Don't delay. Don't put it off. Mail the coupon today. Or use postcard if you prefer.

Write for our new catalogue showing the most complete line of portable and desk models ever offered.

**FREE TOUCH TYPING COURSE**



**MAIL COUPON**

for full facts about this astounding offer

REMINGTON RAND INC. Dept. 189-11, BUFFALO, NEW YORK.  
Please tell me how I can buy a new Remington Portable Typewriter for only 10c a day. Also enclose one of your new catalogues.  
Name .....  
Address .....

a matching transformer in the plate circuit to couple to the headphones. This transformer is not needed but was used as it was at hand. The phones could just as well be placed directly in the plate circuit of the 37 as the plate current in only a few mills (milli-amperes). The tone control is of the four-point switch type used for replacement on broadcast sets, and is connected from the grid of the 37 to ground.

Looking at the front view of the set, the tone control is the right-hand knob; the audio stage being the tube and transformer at the right hand rear of the chassis. For amateur work in a "noisy" location the addition of this audio stage is greatly appreciated. In the author's receiver the 37 is impedance-coupled to a final audio stage using a 2A5, the primary of the audio transformer in the plate circuit of the 37 serving as the plate impedance, while a 500,000 ohm potentiometer is the grid resistor for the 2A5, the movable contact going to the grid, thereby giving us a volume control on the last audio. The headphones are left connected to the audio transformer and when used, the speaker is turned off by means of the last audio stage volume control.

### R.F. Stage a Worthy "Added" Feature

Experiments with a stage of tuned R.F. ahead of the first detector removed all doubt as to its "justification" and left us with the firm impression that we had indeed been missing something worthwhile and did not know it. The pre-selector stage is the coil and tube on the left rear of the chassis, the tuning condenser being controlled by the upper left-hand knob on the panel. The R.F. circuit is given in Figure 1. Be sure to disconnect the ground lead to the detector "Ant" coil before hooking it up to the R.F. stage. A type 78 tube was used, although the type 6DG could be used without any circuit changes.

As the set was to be used mostly for amateur work a 24 plate midget variable condenser was used to tune the R.F., but for all-around work a .00015 mf. size is recommended. A more elaborate set-up would be to use three-gang condensers on the main and band-spread tuning dials. In our case the midget covered the bands very nicely, all tuning over any one band being done with the band-spread dial and with slight adjustments of the R.F. knob.

Four-prong plug-in coils, of the same type as used in the detector and oscillator stages, are employed for the pre-selector stage, although a tapped coil might also be used in this position, if one wished to avoid using another plug-in coil. As for actual results after adding this R.F. stage, a decided increase of the signal-to-noise ratio was at once apparent, together with a very much better "over-all" gain, plus a distinct increase in selectivity—something most amateurs always want but never seem to have enough of.

### Parts for 2-Tube Superhet

- Two sets of standard S-W receiving coils Na-ald (Bud).
- 1—2-gang .00015 mf. variable condenser National (Hammarlund).
- 1—.000015 mf. variable condenser (Trimmer), National (Hammarlund).
- 1—.00075 mf. fixed mica condenser (Cornell-Dubilier).
- 2—.0001 mf. fixed mica condensers (Cornell-Dubilier).
- 1—.00025 mf. fixed mica condenser (Cornell-Dubilier).
- 1—.1 bypass condenser (Cornell-Dubilier).
- 2—3x0.1 mf. bypass condensers (Cornell-Dubilier).
- 2—465 kc. intermediate transformers (National, Hammarlund).
- 1—50,000 ohm, 1 watt resistor, Ohmite.
- 1—250 ohm, 1 watt resistor, Ohmite.
- 1—7,000 ohm, 1 watt resistor, Ohmite.
- 1—30,000 ohm, 1 watt resistor, Ohmite.
- 1—150,000 ohm, 1 watt resistor, Ohmite.
- 1—350 ohm, 1 watt resistor, Ohmite.
- 1—500,000 ohm, 1 watt resistor, Ohmite.
- 1—20,000 ohm, 1 watt resistor, Ohmite.
- 1—50,000 variable potentiometer, wire-wound, Electrad.
- 1—2A7 wafer socket, Na-ald.



**POSTAL PRESENTS**  
**The GREAT '35 ALL-WAVE**



**WITH NEW ENGINEERING FEATURES**

That make possible this outstanding receiver which bettered the performance of the set that won all foreign DX tests. Postal Custom built receivers are now in use in every continent in the World.

**OVER 50 IMPORTANT FEATURES**

Such as the exclusive Postal Triple Drawer Coils, built in Tuned Radio Frequency pre-selector stage, triple tracked continuous band spread, latest electron coupled oscillator, C.W. audio beat oscillator, 4 1/2" calibrated illuminated main tuning control, AVC with dual volume controls precision tuning meter, ten latest type tubes, custom built, 13 to 550 meters, etc.

THE CUSTOM BUILT 10 TUBE POSTAL '35 IS SOLD WITH A 10 DAY TRIAL MONEY BACK GUARANTEE, AND AT A SURPRISINGLY LOW COST FOR A GENUINE CUSTOM BUILT SET. WRITE IMMEDIATELY FOR FREE COMPLETE DETAILS AND PROOF OF ITS OUTSTANDING PERFORMANCE.

**POSTAL RADIO**  
135 B LIBERTY ST. NEW YORK, N.Y.

**I AM A MURDERER . . .**

of NOISE. I can't stand disturbing clicks, buzzes and crashes. I kill noise before it enters the radio set I protect. I do, however, allow the full signal strength of all radio stations to enter. I am the new, patented and guaranteed

**LYNCH**  
**"HI-FI" SIMPLEX ANTENNA SYSTEM**  
(where you have all the room you want) and the  
**"HI-FI" DUPLEX ANTENNA COUPLING SYSTEM**  
(for limited space)

Both systems have noise-reducing properties on wave lengths from 5 to 600 meters impossible of attainment by other systems. No ticky spreading, cumbersome metal tubing or mesh. Installation is simplicity itself. One system is a complete kit—the other can be used with any existing aerial. INVESTIGATE

At Leading Radio and Dept. Stores, or Write Us for Full Details

**ARTHUR H. LYNCH, INC.**  
227 Fulton St., New York, N. Y.

**World Short Wave Set**

Correct Engineering and Superior Parts. Hammarlund, Pilot, make the World Short Wave Sets outstanding in their field.

Foundation Kit: 2 tube set—World Wide Reception with 4 Plug-in Coils—10 to 200 Meters. Simple to Assemble. . . . . \$4.65  
3 Tube Kit . . . . . 6.75  
Separate Power Pack . . . . . 4.45  
Broadcast Coils—200-500 meters. . . . . \$9

Wired and Tested \$1.25 extra.  
These kits also in A.C. at same price.

We manufacture a Complete Line of Short Wave Sets at the Lowest Prices.

Write for full information.  
25% deposit with mail orders.

Save by dealing direct with the manufacturer.

**NATIONAL RADIO DIST. CO.**

406 W. Communipaw Ave., Dept. S, Jersey City, N. J.

**PATENTS — TRADE MARKS**

All inventions submitted held confidential and given persons' attention by members of the firm.  
Form "Evidence of Conception" and instructions  
"How to Establish Your Rights"—Free  
**LANCASTER, ALLWINE & HOMMEL**  
PATENT LAW OFFICES  
475 Bowen Bldg. Washington, D. C.

- 1—6F7 wafer socket, Na-ald.
- 2—4 prong wafer sockets, Na-ald.
- 1—antenna ground strip, Na-ald.
- 1—phone output plug, Na-ald.
- 1—4 wire battery cable.

**Parts List for Pre-Selector**

- 1—set of 2 winding coils, 15 to 200 meters. Na-ald.
- 1—coil socket, 4 prongs, Na-ald.
- 1—6 prong tube socket, Na-ald.
- 2—.1 mf. by-pass condensers, Cornell-Dubilier.
- 1—140 mmf. tuning condenser, Hammarlund.
- 1—400 ohm resistor, Ohmite.
- 1—50,000 ohm resistor, Ohmite.
- 1—type 78 or 61G6 tube, RCA Radiotron (Sylvania).

**Parts List for Audio Stage**

- 1—100,000 ohm resistor, Ohmite.
- 1—500,000 ohm resistor, Ohmite.
- 1—2000 ohm resistor, Ohmite.
- 1—.01 mf. condenser, Cornell-Dubilier.
- 1—.1 mf. condenser, Cornell-Dubilier.
- 1—tone control, see text.
- 1—output transformer, optional. (Thor-darson).
- 1—5 prong wafer socket, Na-ald.
- 1—37 tube, RCA Radiotron (Sylvania).

**Plug-In Coil Data (Na-Ald; Bud)**

Meters Wave-length	Grid coil turns	Ticker turns	Distance between 2 coils
200-80	52 T. No. 28 En. Wound 32 T. per inch	19 T. No. 30 En. Close Wound (C.W.)	1/4"
80-40	23 T. No. 28 En. Wound 16 T. per inch.	11 T. No. 30 En. C. W.	1/4"
40-20	11 T. No. 28 En. 3-32" between turns C. W.	9 T. No. 30 En. C. W.	1/4"
20-10	5 T. No. 28 En. 3-16" between turns	7 T. No. 30 En. C. W.	1/4"

Coil form—2 1/4" long by 1 1/4" dia. 4-pin base.

**Thor "RGH-5" Set**

(Continued from page 412)

**List of Parts**

- COILS:**
- 2—Sets of six prong coils (8 coils).
  - 2—Thor R.F. chokes.
  - 1—NS14, 300 henry plate choke.
  - 1—Thor power transformer, 700V-75MA.
  - 1—Special speaker for parallel 2A5's.
- CONDENSERS:**
- 1—140 mmf., two gang condenser.
  - 1—25 mmf., midget condenser.
  - 2—Thor 8 mf., 450V electrolytic condensers.
  - 4—25 mf., 200 volt by-pass condensers.
  - 2—25 mf., 300 volt by-pass condensers.
  - 1—5 mf., 300 volt by-pass condenser.
  - 1—.02 mf., 300 volt by-pass condenser.
  - 1—.01 mf., 300 volt by-pass condenser.
  - 1—.002 mf., 300 volt by-pass condenser.
  - 1—.0003 mf., 300 volt by-pass condensers (mica).
  - 1—.0001 mf., condenser (mica).
- RESISTORS:**
- 1—10,000 ohm potentiometer, with switch.
  - 1—10,000 ohm variable control.
  - 1—25,000 ohm one watt.
  - 1—5 megohm half watt.
  - 1—500,000 ohm half watt.
  - 2—300,000 ohm half watt.
  - 1—100,000 ohm half watt.
  - 1—40,000 ohm half watt.
  - 1—15,000 ohm half watt.
  - 1—350 ohm half watt.
  - 1—4,000 ohm half watt.

- OTHER REQUIREMENTS:**
- 1—Thor RGH 5 chassis, coil shields, and panel.
  - 1—Crowe No. 125 airplane dial, escutcheon plates and pilot light bracket.
  - 4—Knobs.
  - 2—58 tube shields.
  - 2—58 tube shields.
  - 6—Wafer sockets.
  - 2—6 prong coil sockets.
  - 3—Binding posts.
  - Resistor racks.
  - Line cord and plug.
  - No. 18 hookup wire.
  - Solder and hardware.

**LATEST TECHNICAL INFORMATION . . . .**

**Yours for 10c.**



● NOW AVAILABLE. A convenient 104-page Manual containing essential information users must have to get optimum performances from any device using vacuum tubes.

Complete data on over 90 receiving tubes. Base Symbols. Recommended Operating conditions, circuit applications, amplifier classifications. Over 150 cuts and diagrams. Represents months of painstaking research by Sylvania's famous technical staff.

This Manual is as necessary as your voltmeter. Just fill in the coupon, attach 10c in stamps and mail.

**YOURS! FOR 10c IN STAMPS**

Makers of  
**SYLVANIA TUBES**  
**HYGRADE LAMPS**  
**ELECTRONIC PRODUCTS**  
© H. S. Corp., 1934

Factories  
**EMPORIUM, PA.**  
**ST. MARY'S, PA.**  
**SALEM, MASS.**  
**CLIFTON, N. J.**



**10c—TECHNICAL MANUAL—10c**

Hygrade Sylvania Corporation  
Emporium, Pennsylvania (D-2)

Please send me the new Sylvania Technical Manual. I enclose 10 cents in stamps.

NAME .....

ADDRESS .....

CITY ..... STATE.....

**ALL ELECTRIC ALL-WAVE AIR SCOUT ONLY SET OF ITS KIND IN THE WORLD**

Invented by H. G. Cisin Pat Pending U.S. Serial No. 592,586

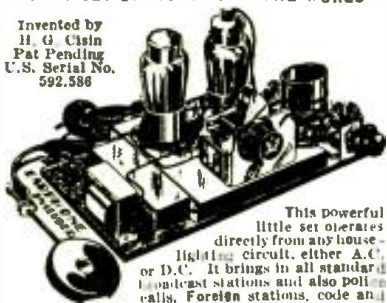

This powerful little set operates directly from any household lighting circuit, either A.C. or D.C. It brings in all standard broadcast stations and also police calls, foreign stations, code and trans-Atlantic phone conversations. Uses five plug-in coils to cover band from 10 to 550 meters. Compact and light—Makes an ideal portable. Will operate several headsets simultaneously and will work on a short indoor aerial. Complete Set, with two tubes, earphone, two coils covering band from 70 to 550 meters. Ready to plug in and use. Postpaid... Same as above, less earphone.

**\$8.50**

**\$8.00**

Postpaid Battery-Operated All-Wave Air Scout—complete with tube, earphone, two coils, ready to use (less inexpensive batteries).....

**\$5.95**

Three extra plug-in coils to cover band from 10 to 70 meters. 50c each.

**SUPER DELUXE MODEL All Electric ALL WAVE AIR SCOUT**



Pat. Pending U. S. Serial No. 592,586 This amazing set incorporates the latest developments in radio engineering, including the new two-in-one 6F7 tube—FOREIGN RECEPTION, OF COURSE—Loud Speaker operation on most local broadcast stations. Equipped with illuminated vernier dial, crackle-finish cabinet, metal chassis, variable selectivity control. Easy to tune. Works on any A.C. or D.C. householding circuit. COMPLETE SET—READY TO USE—with earphone, genuine Arcturus tubes, and five coils, covering band from 10 to 600 meters.....

**\$13.50**

**\$13.00**

Same as Above, less earphone.....

5" Magnetic Speaker for Super Deluxe Model 1.25

**DELUXE MODEL ALL ELECTRIC ALL WAVE AIR SCOUT**

Similar in appearance to the Super Deluxe Model, but for earphone operation only. Crackle finish cabinet, metal chassis, illuminated vernier dial, FOREIGN RECEPTION! COMPLETE—READY TO USE with earphone, Genuine Arcturus Tubes and two coils covering band from 70 to 600 meters.....

**\$10.75**

**10.25**

Three extra plug-in coils to cover band from 10 to 70 meters, each.....

**.50**

**ALL ELECTRIC AIR SCOUT AMPLIFIER**

Can be used with all Air Scout Models, including Battery-operated set. Standard \$8.50 All Electric Model, Deluxe and Super Deluxe Models. Will also work on any other set. Contains two powerful audio stages, with 77 tube in first stage and 43 power output tube. Uses a 25Z5 rectifier. Self-contained Power Supply. Operates from any A.C. or D.C. socket. Full-toned dynamic speaker. Chassis and wood baffle. Enormous volume. Foreign stations on speaker. Price Complete, less tubes.....

**\$9.95**

Kit of Three Matched Arcturus Tubes.....

**2.55**

Free Circulars Available.

**ALLIED ENGINEERING INSTITUTE**

96 Park Pl. Dept. S-11 New York, N. Y.

**RADIO BARGAIN CATALOG**

**FREE** Send for 24-page Bargain Catalog showing the complete new 1935 Golden-Tone line of radios. Many models to choose from, including world-wide all-wave, dual wave, short wave, midsets, consoles, 32-volt Air Cell car radios, etc. All sent on 30-day HOME TRIAL. Before you decide get our catalog and save money. Prices from \$9.45 up. Only catalog giving cabinet and chassis photos, circuit diagrams and complete engineering specifications. Deal direct, save half. We pay postage. GOLDENTONE RADIO COMPANY, Dept. 106, 4180 Dakman Blvd., Detroit, Mich.

**RADIO ENGINEERING**

broadcasting, aviation and police radio, servicing, marine radio telegraphy and telephony, Morse telegraphy and railway accounting taught thoroughly. Engineering course of nine months' duration equivalent to three years of college radio work. All expenses low. Catalog free. School established 1874. Dodge's Institute, Turner St., Valparaiso, Ind.

**A New Sensitive Super-Het**

(Continued from page 411)

ticular point to which this receiver will tune, from the lowest to the highest frequency. Automatic volume control is provided in this set and by a simple flip of a switch, the volume can be controlled either manually or automatically. The automatic control effectively reduces fading, present on many short-wave stations at times. Referring to the circuit diagram, you will find that 10 tubes are used. A 58 is used in the tuned radio frequency stage for increased sensitivity and reduction of image response. A 57 first detector and a 56 high-frequency oscillator. Two type 58's are used in the intermediate frequency amplifier which is tuned to 465 kc. Tuned standard Litz I.F. transformers are used. The C.W. beat oscillator is a 58 in the electron-coupled circuit. The duties of second detector, automatic volume control stage and first stage of audio, are performed by the 2B7 tube. This feeds directly into the two 2A5 power amplifier pentodes. Needless to say the speaker can be driven to full capacity and the "foreign" stations fairly shake the room!

**S. W. Scout News**

(Continued from page 402)

almost every morning between 5:30 and 7:00 A. M., E.S.T. The carrier is rather jerky and fades very rapidly but the station nevertheless compares with VK3ME in every way. The wavelength is 10.740 kc.

There are several S.A. coming through very nicely at this post. The familiar "Hello America" can be heard regularly from HC2RL every time they are on the air. PRADO is received very well every Thursday night from 9:00 to 11:00 P. M., E.S.T. On August 12th this station was heard at 5:30 P. M. radiating a program intended for the Ecuadorian Colony in Paris. The wavelength used for this transmission was 15,300 kc. However, their regular frequency is 6,618 kc. The quality of both stations is surprising. On August 7th XEB came through very nicely. I write XEB, because that was announced, but I suppose it is customary to keep the long-wave station on the air and not "cut" for the SW station announcement, which actually was XEBT. HJ5ABB was heard lately, just above the noise level. Their announcements are "Achay hota thing—co ah bay bay". Usually a "crowing rooster" identifies this station. Address them Apartado 270, Cali, Col. The Brazilian government station continues to come in very strong. The best time to receive them is immediately after GSB signs off in transmission IV. The wave length 31.5 meters.

At present a real treat can be had by listening to either GSB, DJD, or Pontoise on 25.2 meters. Your favorite type of entertainment, whether it be dance music from London, political propaganda from Germany, or classical music from Paris, comes in with local station volume. HBL and HBP continue to come in very strong on Saturday evenings from 5:30 to 6:15 P. M., E.S.T. The Belgium station ORK is heard with only fair volume. CTAA is being received very well lately. They usually play records and announce about every 15 minutes. The identification signal is "cuckoo, cuckoo, cuckoo".

The Australians, VK2ME and VK3ME are coming in very fine. At present both are QSA/R9. VK2ME, as many listeners know, radiates programs dedicated to various states of the Union.

Several new stations were heard at this post during this month. In the first case I write new, because this station is seldom reported. It is RAU, located in Tashkend, U. S. S. R. They can be heard in the early morning phoning "Moskva". The time was 6:00 A. M., E.S.T. The signal was fairly weak but quite intelligible. The frequency was 15,100 kc.

**BARGAINS**

ORDER DIRECT FROM THIS ADVERTISEMENT—WE DO NOT ISSUE ANY CATALOG

**G. E. Phonograph Motor**

ONLY **\$3.95**

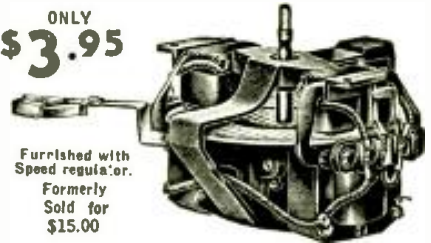

Furnished with Speed Regulator.

Formerly Sold for **\$15.00**

Variable speed induction type self-starting, 110 volt, 60 cycle, A.C. with lever control. Speed range from 5 to 200 RPM. Can be installed in place of old-fashioned, hand-winding speed motor. Fits any cabinet. Also ideal for display turn-table, and a hundred other uses. These G. E. Electric Motors are brand new, in original factory cartons. Same motor that formerly sold for \$15.00, only \$3.95 as long as supply lasts. Manufacturers and dealers, please write for special quantity prices.

Shipping Weight, 11 lbs.

**G. E. MOTORS**

These Motors were manufactured by the General Electric Company and originally intended for use by a large manufacturing company.



Here are the specifications: 1/30 H.P.—4800 R.P.M. Universal A.C. and D.C. 110 volts Instant reverse. Diameter 3 inch, length 5 inch. Shipping weight, 3 lbs.

Add 25c for special packing and mailing anywhere in U. S. A.

**\$2.45 Each**

Original Price, \$12.00

WHILE THEY LAST

**Westinghouse Power Generators**

Manufactured by Westinghouse for U. S. Signal Corps. Built-in commutator takes off the generated D.C. Three leads extend through the casing to permit a 4 1/2 V. flashlight-type battery to be switched into circuit for starting, and to control the A.C. output. Rotated at its normal speed of 4,500 r.p.m., the output is 200 W., at 115 to 125 V. (on open circuit), 900 cycles. The rotor turns in ball bearings. Shaft length (driving end), 2 ins.; diameter 5/16 in.; the end is threaded for a distance of 3/4 in. Base dimensions exclusive of the shaft, 4 1/2 x 6 1/2 in. in diameter. Guaranteed new and perfect.



While They Last! **\$4.95**

Here is what one of our customers writes: "These generators are being used in a small fishing village, where the only current is supplied from a 2K.W.-D.C. generator. As it was impossible to use A.C. sets and especially my short-wave transmitter using two 45 tubes, one of the generators is used to supply my two A.C. receivers and the other to supply power for the transmitter. Both generators are run by a 1/4 horsepower motor. These generators perform perfectly and have been absolutely trouble free. The voltage and current regulation is remarkably stable, taking a considerable overload." (Name supplied on request.)

Remit by check or money order for full amount of each item—Shipped Express Collect if sufficient money is not enclosed for parcel post. No C.O.D. order accepted—Money refunded if not satisfied.

**WELLWORTH TRADING COMPANY** 560 W. Washington Street CHICAGO, ILL. SW-11-34

Enclosed you will find my remittance of \$..... for which please send me  
 G. E. Phonograph Motor, \$3.95 each.  
 Power Generator, \$4.95 each.  
 G. E. Motor, \$2.70 (including packing and postage).

Name .....  
 Address .....  
 City..... State.....



# ALL-WAVE Antenna Systems

SPECIAL For This Month Only!

**COMPLETE READY TO HANG UP**  
 No. 895  
**INVERTED L**  
 (78 ft. flat top) with  
 35 ft. Giant Killer  
 cable lead-in.

Complete with new Universal Coupler and Double Lightning Arrester. Net... **\$6.50**  
 Kit Lynch Materials to build No. 895 ..... Net... **\$4.69**

Other types available in Doublet form with 4-wire cage flat tops and transposed lead-ins. Write for special prices.

## LYNCH MATERIALS USED EXCLUSIVELY THE IDEAL STATION LOCATOR

(Beat Note Oscillator)  
 Will indicate every station that could be brought in when you are tuning your receiver. Indicates station by whistle, turn switch off, whistle disappears, stations remain at peak. Powered from receiver. **\$8.95**  
 For superhets only.

**THE "MISSING LINK"**  
 Phone Receptor for Receiver Without Phone Jack  
 Inserting phone plug automatically silences speaker. No disturbing of receiver wiring. .... **\$3.95**

**AMPLIVOX LABORATORIES**  
 227 Fulton St., Dept. SW-11 New York, N. Y.  
 Chief Engineer—Sol. Perlman, E.E., Consulting Engineer on Antenna Problems to A. H. Lynch, Inc.

## The DX2 All-Wave Receiver



A sensitive, powerful and self-engineered 2 tube receiver capable of world-wide short-wave reception. Uses 32 and 30 type tubes. Possesses the sensitivity and high gain that is characteristic of screen grid regenerative detectors, the excellent tonal qualities of the resistance coupled amplifier, and an extremely smooth regeneration control. Beautiful black crackle finished metal chassis and panel. Weight 5 lbs. Highest quality parts and simple to build. Operates on 1.45 V volt B battery and 2 dry cells. Coils for 18-200 meters and instructions included. Foreign reception is guaranteed. C.D.D. orders filled promptly. Circular on request. **Kit....\$4.45**

Wired and tested, extra..... **\$1.35**  
 Arcuturus tubes..... **1.50**  
 Broadcast coils..... **1.15**  
 Acme 4000 ohm phones..... **1.35**

### Centrallion Engineering Co.

Dept. Swc. 461 Fourth Ave., New York, N. Y.

## SEND NO MONEY!



This illustration is of one of six models in Kit form that we make—each a leader in its line—A.C., D.C. or Battery models. All of them may be purchased from your local dealers. Write for illustrated circular FREE.

**CONSTRUCTRAD, INC. (Dept. 11)**  
 168 Washington Street, New York City

MANY VALUABLE ARTICLES have appeared in past issues of **SHORT WAVE CRAFT**  
 For Back Numbers available see Page 444

## HI-FI Antenna System

(Continued from page 411)

Impedance of the new Lynch "HI-FI" receiver Transformer is also approximately 70 ohms. The output impedance of this transformer may be selected by means of simple telephone tip-jacks to match receivers with either high or low input impedance. A third connection is provided on this transformer which enables the entire antenna plus the lead-in, to be utilized as a regular T type antenna, in areas where noise occurs on one band and not on the others.

The new type of all-wave antenna system employing a doublet for the horizontal portion of the antenna may be made to operate satisfactorily over all of the existing wave-bands as a result of some important developments in impedance matching transformers (fig. 2) combined with accurate fixed condensers. The fundamental system employed in this intricate network is shown in Fig. 1 and the theory of the operation of this complicated looking system is not very difficult to understand. It is common radio engineering knowledge that fixed condensers have a lower impedance at high frequencies than they do at low frequencies. Therefore, when the receiver is tuned to the high frequencies, that is, any of the short-wave bands, the impedance of the two small condensers shown in Fig. 1, offers the path of least resistance to the incoming radio waves which pass directly through the condensers to the low impedance transmission-line. From this line it goes into the receiver impedance matching transformer and then, by one of three distinct methods, directly to the receiver; for details see Fig. 3.

It is also well understood in radio engineering circles that a doublet antenna cut to a size which is most efficient on the short-wave band will not function satisfactorily when used in the broadcast band. For this reason the transformers shown at either side of the dotted line in Fig. 1 are utilized to carry the broadcast signal into the transmission line at a considerable gain over the signal which would be possible without these transformers. In this case the impedance of the transformer is very much lower than the impedance of the fixed condenser and the incoming broadcast signal passes through the transformer in preference to the condenser.

For the radio amateur, who is interested in both transmitting and receiving, these new Lynch Systems offer a new era in the field of long distance QSOs.

Regardless of the frequency for which a particular ham doublet is designed, its impedance is practically identical to the impedance of Lynch Giant Killer Cable. The only requirement for most efficient operation on any particular frequency is a 1/2 wave doublet, cut to suitable length for that frequency and the New "HI-FI" Receiver Transformer. In this case, the Giant-Killer Cable may be any length, irrespective of the fundamental frequency.

This arrangement makes it unnecessary to make any changes in the input circuit of the receiver.

Since Lynch Giant-Killer Cable has a break-down voltage of 2,500, the same doublet and transmission line may be used for both transmitting and receiving. To do this, a simple, double-pole, double-throw switch is used to throw the lower end of the Giant-Killer Cable to the Lynch "HI-FI" Receiver Transformer, in the receiving position and to the impedance matching network of the transmitter, in the transmitting position.

### WARNING

Recently, an individual who names himself Robert Carey, Jr., has been traveling in the middle west, taking subscriptions to this and other magazines. This man is a swindler and all monies which he collected he kept for himself, giving a FAKE receipt.  
 Do not pay money to strangers for subscriptions unless he can produce a letter signed by the publisher of the magazine and show you other credentials.

Heads of Police Departments—if the individual referred to above should be apprehended, please telegraph us collect and we will immediately appear to prosecute him.  
 —THE PUBLISHERS.



## HIGH FREQUENCY By-Pass Condensers

ANOTHER Sprague development of utmost importance to every amateur and short wave fan. . . .

. . . Oil-impregnated Short Wave Condensers guaranteed as excellent substitutes for mica condensers in any of the circuits illustrated. And look at the prices!—from 50% to 75% less than you have been paying for mica units.

Just the thing for by-pass purposes in Short Wave receivers, although they are not recommended as series padding condensers or as mica substitutes in tuned circuits. Thus, while not a universal substitute for mica, Sprague Short Wave Condensers CAN be used with entire safety and effectiveness in the circuits mentioned.

YOU JUST CAN'T BREAK THEM DOWN. TESTS AT HEAVY CURRENT AND TREMENDOUS HEAT HAVE SHOWN NO FAILURES. QUALITY AT A PRICE BECAUSE OF NEW, IMPROVED CONSTRUCTION. OIL CONDENSERS ARE ALWAYS BEST.

Sturdy — self-supporting. Unusually small — from one-third to one-half as large as mica condensers of the same ratings. Metal encased — non-inductive — extremely low power factor — impregnated with a specially developed oil—1500 V. and 1000 V. continuous D. C. rating. Guaranteed unconditionally, when used as specified. Sold by leading jobbers. TRY THEM TODAY!

Write for our complete Condenser Catalog including famous Sprague Transmitting Condensers

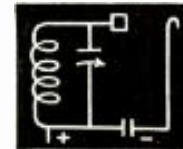

BY-PASS

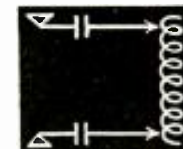

COUPLING (Ant.)

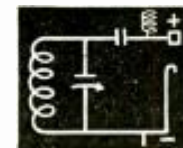

BLOCKING

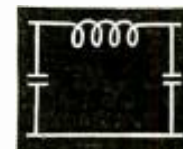

FILTERS (Fone)

Cat. No.	D. C. Capacity	Working Voltage	Diam.	Length	List	Net
SW-22	.002	1500	9/16" by 1	9/16"	\$.45	\$.27
SW-25	.005	1500	5/8" by 1	13/16"	.45	.27
SW-11	.01	1500	11/16" by 1	13/16"	.70	.42
SW-15	.05	1000	7/8" by 2	1/4"	.80	.48
SW-1	0.1	1000	7/8" by 2	1/4"	.90	.54

## SPRAGUE PRODUCTS CO. North Adams, Mass.

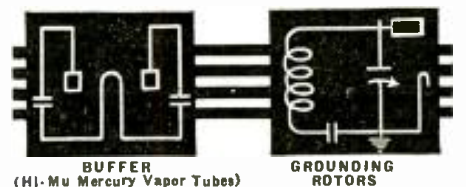

BUFFER (Hi-Mu Mercury Vapor Tubes)

GROUNDING ROTORS

# FREE RADIO'S LEADING CATALOG For 1935!

Send for the most complete and truly timely book in Radio. It will keep you ahead of the field and save you money. Why buy from skimpy seasonal catalogs whose usefulness is confined to a few weeks—or from books a year old? Write today for radio's most valuable catalog—the ALLIED Radio Guide—always timely because of its remarkable completeness, always up-to-the-minute because of its straggling publication date geared to radio progress.



**SEND FOR THIS BOOK IT WILL SOLVE YOUR RADIO NEEDS AT CONSISTENT SAVINGS!**

All-wave and European range sets, battery, 32 volt, and electric models—Short Wave

Transmitting and Receiving equipment—an amazing P.A. listing—test instruments—thousands of replacement parts, tubes and accessories—are packed into the 1935 ALLIED Catalog. Also "Build-your-own" kits. (As kit specialists we can quote for any circuit appearing in any magazine or handbook.) Write today for your FREE copy of the 1935 ALLIED Catalog.

## Allied Radio

833 W. Jackson Blvd., Chicago, Dept. E

- Please send me your FREE 1935 Catalog
- Please quote for Kit described in.....

NAME .....

ADDRESS .....

CITY ..... STATE .....

## HOW TO BUILD, TEST AND REPAIR RADIO SETS



## Radio Construction Library

Including Television, Short-Wave Receivers and Auto Radios. 3 Volumes, 6x9—1177 pages, 561 illustrations.

This practical Library includes: PRACTICAL RADIO—The fundamental principles of radio, presented in an understandable manner. Illustrated with working diagrams. PRACTICAL RADIO CONSTRUCTION AND REPAIR—Methods of locating trouble and reception faults and making workmanlike repairs. Discusses modern Short-Wave Receivers and installations of automobile radios fully. RADIO RECEIVING TUBES—Principles underlying the operation of all vacuum tubes and their use in reception, remote control and precision measurements.

Helps you to understand modern type receiving sets—full of construction data and practical kinks for the experimenter.

**10 Days' Free Examination Easy Terms**

## Free Examination Coupon

McGraw-Hill Book Company, Inc.  
330 West 42nd Street, New York

Send me the new RADIO CONSTRUCTION LIBRARY, three volumes, for 10 days' free examination. If satisfactory I will send \$1.50 in ten days, and \$2.00 a month until \$7.50 has been paid. If not wanted I will return the books postpaid.

Name .....

Home Address .....

City and State .....

Position .....

Name of Company ..... SWC-11-34

## "Break-In" Monitoring

(Continued from page 409)

The lead P1 from the monitor is connected to the plate end P2 of the amplifier choke (in this case, an audio transformer with windings in series) and the filament return is completed by a connection to the "B minus." In the case of receivers using two stages of amplification the lead P1 may well be connected to the plate side of the primary of the last transformer since one stage of audio has proved ample for all harmonic beats up to the eighth (20 meter band).

It is easily seen that the output from both the detector and the monitor is fed simultaneously into the same phones, the same "B" potential being used for all tubes.

When the transmitter key is pressed the detector of course is immediately blocked with excessive R.F. and the only signal heard will be the beat note when the monitor is tuned to the transmitter wave. The frequency corresponding to this dial reading we can now find from the calibration curve.

However, to make assurance doubly sure we let up the key, the detector immediately functions (unless the transmitter output is about a thousand watts, in which case it may be paralyzed for a few seconds) and we tune the receiver over the band till the beat from the monitor is heard. Frequency observation is highly important in these days of uncertain amateur privileges and this system of "check and double-check" is good insurance against having your license cancelled for off-frequency operation.

Assuming that the other station is located in the usual manner, i.e., after a CQ, a call, or on schedule, we now make use of the break-in monitoring system. Your monitor is tuned to your own transmitter while your receiver is tuned to the other station. Thus when the key is up you hear the other station (from your receiver) and when it is down you hear your own signals (from your monitor). No switches to throw, no plugs to fiddle with, no delay, merely pound the key or swing the "bug."

This method of operation has almost the speed and efficiency of a telephone conversation for ordinary "rag-chews," while for "traffic-handlers" it is practically indispensable. It has an application for the DX hound too, for he can immediately tell when the elusive "VK" or "ZI," "comes back" to someone else, and so save himself a lot of useless calling.

Obviously, of course, if the transmitters at both stations are on *exactly* the same frequency, both your receiver and your monitor would be on the same wave as the transmitter and in addition to hearing the other fellow's signals (key up) and the monitor-transmitter beat note (key down) the monitor-receiver beat note will also be heard (key up or down). However this condition occurs very rarely and in any case it is found that a shift of five kilocycles obviates any difficulty.

### Harmonic Monitor Parts List

- L1—18 turns No. 24 D.C.C. wire on a form 1.5 inches in diam.
  - L2—70 turns No. 24 D.C.C. on same form and spaced .25 inches from L1.
  - C1—50 mmf. midget condenser, with large tuning dial (25 mmf.). National.
  - C2—100 mmf. midget condenser, with knob for occasional adjustment. National.
  - C3—.002 mf. by-pass condenser. Cornell-Dubilier.
  - R.F.C.—Radio frequency choke 100 turns No. 30 D.C.C. on half-inch form; or National 2.5 M.H. R.F. choke.
  - T—Battery-operated tube (type '01-A, '00, '30, etc.). RCA Radiotron.
  - R—Filament rheostat for above tube. (A fixed resistor would be better.)
- An aluminum panel, wooden base-board, screws, etc., to complete the job.

# FREE!



108 Page RADIO and SHORT WAVE TREATISE

Over 100 Hook-Ups More Than 1,500 Illustrations

A Veritable Text Book

**NOT JUST ANOTHER CATALOG**  
This completely revised and enlarged 1934 edition contains 108 solid pages of useful radio information, diagrams, illustrations, radio kinks and real live radio merchandise. It contains more valuable radio information—more real live "meat" than many textbooks on the subject. As usual considerable space has been devoted to the beginner in radio.

**PARTIAL LIST OF CONTENTS**  
Chapter Two of "Fundamental Principles of Radio for the Beginner"—The New Tubes, Their Uses, and Their Fundamental Circuits—How to Make Money with Public Address Systems. How to Install and Maintain Them—How to Revamp Six-Volt Battery Sets to Use Two-Volt Tubes—Prize Winning Kinks and Short Cuts in Radio—How to Build the "R T" Beginner's Transmitter—How to Build the Famous Twi-plex Short Wave Receiver—How to Construct an Amateur Radio Transmitter—A Most Modern and Complete Tube Chart Including Socket Connections for all Tubes—Numerous Free Offers, etc., etc.

WRITE TODAY Enclose 5c. coin or U. S. stamps for postage. Treatise sent by return mail.

**RADIO TRADING CO.**  
101A Hudson Street New York City

## KNOW THYSELF!

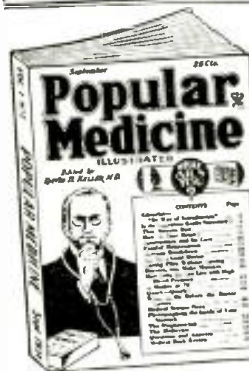

This new monthly magazine is also your medical guide. WHAT AILS YOU? POPULAR MEDICINE tells and advises you thoroughly. Written for you by doctors. Non-technical, yet authoritative for all laymen. Many anatomical illustrations. At All News Stands.

**SPECIAL OFFER! 8 Months for \$1**

Send 15c for Sample Copy Popular Medicine 97C Hudson Street New York, N. Y.

## RADIO'S LIVEST MAGAZINE

Edited by HUGO GERNSBACK



RADIO-CRAFT is devoted not only to the radio experimenter and technician, but also to the beginner in radio. Picture diagrams simplify construction of sets. Kinks show simple ways out of difficult problems. The latest radio equipment is illustrated and described.

8 Months for \$1.00

RADIO-CRAFT is fully illustrated with photographs, diagrams and sketches. Each issue contains over 150 illustrations. 15c for Sample Copy.

## RADIO-CRAFT

99C Hudson Street New York, N. Y.

## WANT A TELEVISION JOB?

Radio and Television are packed with romance. Every hour interesting and immensely profitable. For free details write First Nat'l Television, Power & Light Bldg. Kansas City, Mo., Dept. B-11.



# DATAPRINTS

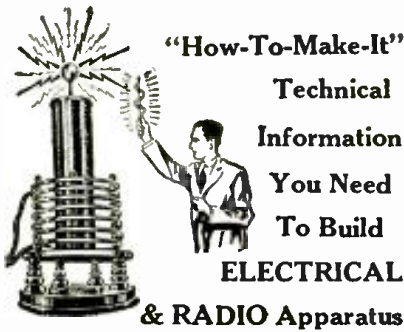

Dataprint containing data for constructing this 3 ft. spark Oudin-Tesla coil. Requires 1 K.W. 20,000 volt transformer as "exciter". See list below. Includes condenser data. **\$.75**

### TESLA OR OUDIN COILS

- 36 inch spark, data for building, including condenser data.....**\$.75**
- 8 inch spark, data for building, including condenser data; requires 1/4 K. W. 15,000 volt transformer; see list below..... **6.75**
- Violetta type, high frequency coil data; 110 volt A.C. or D.C. type; 1" spark; used for "violet ray" treatments and "Experiments"..... **0.50**
- How to operate Oudin coil from a vacuum tube oscillator..... **0.50**
- 3 inch spark Tesla coil; operates on Ford ignition coil..... **0.50**
- 3 inch spark Oudin coil; 110 volt A.C. "Kick-Coil"..... **0.50**
- 20 Tricks with Tesla and Oudin Coils..... **0.50**

### TRANSFORMER DATA

- 1 k.w. 20,000-volt transformer data, 110-volt, 60-cycle primary. Suitable for operating 3 ft. Oudin coil..... **0.50**
- 1/4 k.w. 15,000-volt transformer data, 110-volt, 60-cycle primary. Suitable for operating 8-inch Oudin coil..... **0.50**
- Electric Welding Transformer..... **0.50**
- Induction Coils—1 to 12 inch spark data..... **0.50**

**TELEGRAPHONE** — Records Voice or "Code" signals on steel wire by magnetism. Code can be recorded "fast" and translated "slow." Construction data (special).....**\$.50**

### NEW! RADIO AND TELEVISION.....\$.50 Each

- (Aluminum Order, 2 prints at this Reduced Price.)
- The Final-All Pentagrid A.C.-D.C. "Short-Wave" Converter (3 Tubes).
- A Five-Tube Midset with 2A3's in Push-Pull.
- "All-Wave" Find-All Four (A.C.; no plug-in coils).
- Find All "Autovox"—Newest Five-Tube Auto Rect. A.C.-D.C. Mighty Midset 143 Output, 2525 Hct., Dynamic Speaker)
- 3-Tube Battery Operated Personal Receiver, 2 V. tubes, "Pat" Portable, Sr. (Universal A.C.-D.C., 38 Output, Magnetic Speaker).
- The "Short Wave" Triple Pentode with 44 and 42 Tubes (A.C.).
- The 2-volt Superheterodyne with Latest 2-volt Pentodes (8 tubes).
- Three-Tube Reflex with 56, 58 and 47 Tubes—Reflex Revived with Modern Tubes.
- Triple Pentode Battery Set (Fine Modern Six-Tube). Nine Easy Ways to "Modernize" the Radio Set.
- 7-Tube Television Receiver.

### MAGNET COIL DATA

- Powerful battery electro-magnet; lifts 40 lbs.....**\$.50**
- 110 Volt D.C. magnet to lift 25 lbs..... **0.50**
- 110 Volt D.C., 300 lb., lift electromagnet..... **0.50**
- 110 Volt D.C. solenoid; lifts 2 lb. through 1 in. **0.50**
- 110 Volt D.C. solenoid, lifts 6 lb. through 1 in. **0.50**
- 12 Volt D.C. solenoid, lifts 2 lb. through 1 in. **0.50**
- A. C. Solenoid, powerful 110-volt, 60-cycle..... **0.50**
- MOTOR**—1/16 H.P., 110 volt A.C., 60 cycle (suitable for driving 1" fan, etc.)—Data..... **0.50**
- 60 or 1,200 cycle Synchronous motor..... **0.50**

### MISCELLANEOUS DATAPRINTS

- Treasure Locator..... **0.50**
- 2 K. W. 110 vt. to 18 vt. transformer data.....**\$.50**
- 20 motor circuits—hook-ups..... **0.35**
- 20 practical telephone hook-ups..... **0.35**
- 100 mechanical movements for inventors..... **0.35**
- Polarized Relay—Ultra Sensitive..... **0.50**
- Electro-medical coil (shocking coil)..... **0.50**
- Water-Wheels—How to Build and Light your house..... **0.50**
- 20 Electric Bell circuits..... **0.50**
- Public Address System..... **0.50**
- Electric chime ringer; fits any clock.....**\$.50**

20 "Electrical Tricks" for LODGES and PARTIES.....**\$.50**

How to Fry Eggs on Cake of Ice Electrically.....**\$.50**  
 "Rewinding" Small Motor Armatures..... **0.50**  
**"ENGINEERING SERVICE BY MAIL"**  
 Send Sketch of Your Problem for Estimate.  
 (20% off on orders for \$3.00 or more. No C.O.D.)

**The DATAPRINT COMPANY**  
 Lock Box 322 RAMSEY, N. J.

## New 5-Tube Super-Het

(Continued from page 393)

able to place the two I.F. tubes in shielding cans, in order to reduce the I.F. noise level. A single shielding can, not shown in the photograph, fits over the shields at the back and completely screens both I.F. transformers and tubes.

### The I.F. Coils

The I.F. transformer coils are not at all difficult to wind at home. Each transformer is wound on an old wire bobbin (spool), made of wood, with one end removed, the diameter of the former thus provided being about 3/4". The data for the two transformers will be found in diagrams No. 2 and No. 3. Of the first transformer, L4 is wound first, in one even layer. This is covered by a single layer of transformer insulation tape, over which is wound a single layer of white paper of average newspaper thickness. Any color would work as well, but the white paper is very helpful in winding on the second layer of fine black wire and the wire is then easily wound on in an even layer. Turns data will be found in the two diagrams. On the second coil (the second I.F. coupling is not a transformer) the regeneration coil L6 is not wound over the coil L5, but is wound in a bunch (helter-skelter) on the former at the

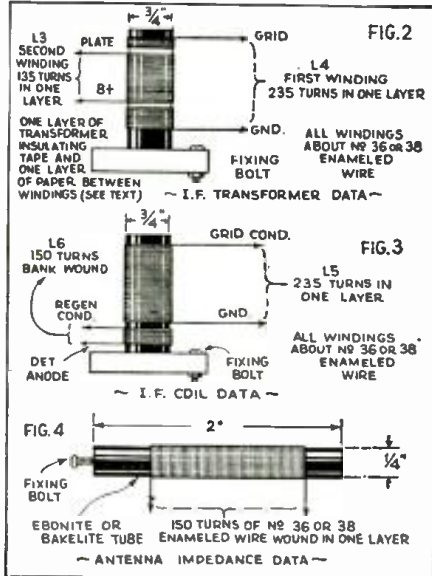

ground end of the coil L5, with a separation of about 3/8" between the two coils. All the coils *must* be wound in the same direction and must be wired up in the sequence shown in the diagrams. When winding the coils L3 and L4, make no mistakes about providing adequate insulation between the two windings, as the full B voltage exists between these two windings and poor insulation here would spell trouble.

Following is the parts list for this receiver:

- R1 0.5 megohm.
- R2 40,000 ohms.
- R3 80,000
- R4 4,000
- R5 250,000
- R6 2 megohms.
- R7 2 megohms.
- R8 10,000 ohms.
- R9 80,000
- R10 10,000
- R11 0.5 megohm (volume control).
- R12 10,000 ohms.
- C1 .0003 mf., fixed
- C2 .0003 mf., fixed.
- C3 .00014 mf. (tuning condenser).
- C4 .01 mf. by-pass.
- C5 .05 mf. by-pass.
- C6 .0003 mf. (pre-set), variable.
- C7 1.0 mf. by-pass condenser.
- C8 .01 mf. by-pass condenser.

## The All-Electric 3 All-Wave Receiver



**Greatest 3 Tube VALUE on the market**

A completely electrified short-wave receiver capable of world-wide reception. See article p. 155 July Issue Short Wave Craft. Uses special circuit

for the new 6F7 (2 tubes in 1 bulb) & IV tubes as screen-grid regenerative detector, audio frequency amplifier, rectifier & complete built-in power supply. Operates entirely from 110 volt AC or DC house lighting circuit. No batteries of any kind required. Owners report reception of European, South American & clearness. Wave-length range is approx. 18-600 meters. Mounted on heavy, black crackle finish metal chassis & panel. Shipping weight 6 lbs. Only additional apparatus needed are tubes and phones. Coils for 18-215 Meters, & instructions included. FOREIGN RECEIPTION GUARANTEED. Circular sent upon request.

**KIT, ASSEMBLED and ready to wire**

**\$.95**

Wired and tested, extra.....**\$.160**  
 Broadcast coils.....**.95**  
 Arcturus tubes.....**1.90**  
 Acme 4000 ohm phones.....**1.35**



**The DC 3 All-Wave Receiver**

One of the most powerful battery operated sets on the market. Owners report England, Germany and others on the loud-speaker. Uses the new 19 (2 tubes in 1 bulb) and 33 tubes as regenerative detector and 2 stage audio frequency amplifier. Uses special filament circuit for low filament current consumption. Provides tremendous volume. Operates loudspeaker on many stations. Constructed of only highest grade materials. Wavelength range of approx. 18-600 meters. Mounted on heavy, black crackle finish metal chassis and panel. Shipping weight 7 lbs. Coils for 18-215 meters, and instructions included. FOREIGN RECEIPTION GUARANTEED. Circular sent upon request.

**KIT, ASSEMBLED**

**\$.95**

Wired and tested, extra.....**\$.160**  
 Broadcast coils.....**.95**  
 Arcturus tubes.....**1.90**

loud-speaker. Uses the new 19 (2 tubes in 1 bulb) and 33 tubes as regenerative detector and 2 stage audio frequency amplifier. Uses special filament circuit for low filament current consumption. Provides tremendous volume. Operates loudspeaker on many stations. Constructed of only highest grade materials. Wavelength range of approx. 18-600 meters. Mounted on heavy, black crackle finish metal chassis and panel. Shipping weight 7 lbs. Coils for 18-215 meters, and instructions included. FOREIGN RECEIPTION GUARANTEED. Circular sent upon request.

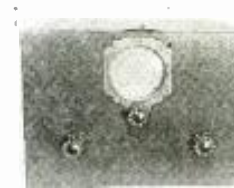

**The "AE4" S-W Receiver**

Designed for those who demand the best in results and appearance. Uses 6F7, 43, and 12Z tubes in new high-gain circuit, as screen-grid RF amplifier, regenerative detector, power audio amplifier, rectifier and complete built-in power supply. Operates entirely from 110 volt AC or DC house lighting circuit. Free from dead spots. Tremendous headphone volume. Will operate a loudspeaker on many stations. Mounted in heavy, black crackle finish metal cabinet, presenting a very pleasing appearance. FOREIGN RECEIPTION GUARANTEED. Circular sent upon request.

**KIT, ASSEMBLED and ready to wire**

**\$.11.45**

Wired and tested, extra.....**\$.200**  
 Arcturus tubes.....**2.75**

plifier, regenerative detector, power audio amplifier, rectifier and complete built-in power supply. Operates entirely from 110 volt AC or DC house lighting circuit. Free from dead spots. Tremendous headphone volume. Will operate a loudspeaker on many stations. Mounted in heavy, black crackle finish metal cabinet, presenting a very pleasing appearance. FOREIGN RECEIPTION GUARANTEED. Circular sent upon request.

**C.O.D. ORDERS FILLED. PROMPT SHIPMENT. EILEN RADIO LABORATORIES**  
 Dept. SC6, 463 Fourth Ave., New York, N. Y.

Just Off the Press!

**RADIO'S GREATEST VALUES**

100 Pages. Filled with Latest Design Portable, Mobile and Rack & Panel, Public Address Amplifiers, Short-Wave and All-Wave Receivers and Converters, Inter-Office Call Systems, Test Equipment, Replacement Parts, Kits, Tubes, and Accessories—all at Unbeatable Rock Bottom Prices! Send For Your Copy To-Day!



**COAST TO COAST RADIO CORP.**  
 123 S. WEST 17th STREET, NEW YORK, N. Y.

## LEARN CODE

You Can Become a Fast, Capable RADIO OPERATOR at Home

The CANDLER SYSTEM MAKES IT EASY FOR YOU!

CANDLER Students Never Flunk. Advise us what license you seek and we will show how easily it is to be obtained.

Leading Instructors and Operators in U. S. Army, Navy and Aviation are CANDLER trained. Fastest and most skilled Amateurs and Commercial ops during past 23 years were CANDLER trained. McElroy held Class "A" championship 13 years. Jean Hudson, W3BAK, 9 years old, won championship Class "E" two months after enrolling for JUNIOR SCIENTIFIC CODE COURSE. No "robots" used.

If you're wise, you'll get your SPEED where the champions got theirs. Any skilled Amateur or Commercial Op will tell you of the superiority and importance of CANDLER SYSTEM training for Speed and Accuracy.

THREE GREAT COURSES—Junior Scientific Code Course for beginners. Advanced Course for those with speeds over 10 wpm who want to do 40 to 50 wpm and copy behind. "Mill" Course for fast, accurate copying.

Send for BOOK OF FACTS for Radio Ops., Amateurs and Beginners.



All questions answered promptly. No obligation.

CANDLER SYSTEM CO., Dept. S-11  
6343 S. Kedzie Ave., Chicago



World's Only Code Specialist

## Baird OCTOCOILS



16 to 30 Meters    29 to 58 Meters    54 to 110 Meters    103 to 225 Meters

4 PRONG, 4 Coils to Set, 15 to 225 Meters. \$2.50 PER SET of 4 Coils; 65c Each Coil  
6 PRONG, 4 Coils to Set, 15 to 225 Meters. \$3.50 PER SET of 4 Coils; 90c Each Coil

Can be applied with better results to any circuit using short-wave plug-in coils. Standard since 1927—used in over 60 foreign countries.

Broadcast Coil—4 prong, \$1.00; 6 prong, \$1.50. Made of genuine Bakelite in distinctive colors using heavy enameled wire and packed in individual boxes. BEWARE OF IMITATIONS. We are the pioneer manufacturers of popular priced short-wave plug-in coils. SATISFACTION GUARANTEED. Up-to-date diagrams included FREE.

Shortwave & Television Corp.,  
70 Brookline Ave., Boston, Mass.

Gentlemen: Please send me postpaid ..... sets of OCTOCOILS —4 —6 prong (check which type you want) for which I enclose \$.....

NAME .....  
ADDRESS .....

## Another Reason Why



The TRIMM FEATHERWEIGHT phones will bring in weaker signals. The great number of turns of wire on the Electro Magnet, together with the specially treated Magnetic iron in the core results in a greater change in the Magnetic flux causing more strength to the weak signals.

DX in comfort with Trimm Featherweight phones. Buy from your local dealer.

TRIMM RADIO MFG. CO.  
1528 Armitage Ave. Chicago, Ill.

- C9 .0003 mf. (pre-set), variable.
- C10 .0003 mf. (regeneration condenser).
- C11 .0003 mf. fixed condenser.
- C12 .0001 mf. fixed condenser.
- C13 .1 mf. by-pass condenser.
- C14 .01 mf. by-pass condenser.
- C15 1.0 mf. by-pass condenser.
- C16 1.0 mf. by-pass condenser.
- C17 .01 mf. (tone control—optional).
- 4 4-pin tube sockets; Na-Ald.
- 1 5-pin tube socket; Na-Ald.
- 1 6-pin tube socket; Na-Ald.
- 1 Chassis as per specification; Blank (Korrol).
- 1 Illuminated disc drive.
- 1 Baseboard type 4-pin socket for plug-in coils.
- 1 5:1 audio transformer.
- 1 "On-Off" snap switch.
- 3 Formers and wire for coils as described.
- Quantity hook-up wire and insulating sleeving.
- Quantity nuts and bolts.
- Battery cables for 7 connections.
- 1 pair binding posts, "antenna" and "ground."
- 1 R.F. choke (R.F.C. 2) (not a short-wave choke).

### Bias Battery

The bias battery for the 34 type I.F. pentode tube is mounted directly underneath the chassis and consists of a small capacity 3-volt pocket lamp battery.

After having ascertained that the receiver is functioning, it is necessary to adjust the I.F. tuning condensers correctly. Set the condenser (3) about three-quarters of the way to maximum capacity and slowly adjust the condenser (6) until a sudden increase of general sensitivity is noticed. When these two circuits are in tune, they can be left alone for future use. The best setting for these condensers for local conditions will have to be found by experiment but the best results will generally be obtained by tuning to a low frequency (high condenser setting). On the other hand, they must also be adjusted to a point at which the second detector will produce easy oscillations when required so that these points must be borne in mind when setting these condensers.

### U. S. Stations Heard in England

Using this receiver in England, the writer has received most of the usual short-wave stations, some at extraordinary volume. When reception conditions are at all good, many of the U. S. stations are heard at really good strength on a fairly large dynamic speaker, while some of the beam stations on the American and Canadian trans-Atlantic telephone circuits come in at absolutely "local station" strength at certain times.

### Na-ald Plug-in Coil Data

Meters Wave-length	Grid coil turns	Tickler turns	Distance between 2 coils
200-80	52 T. No. 28 En. Wound 32 T. per inch.	19 T. No. 30 En. Close wound (CW)	1/4"
80-40	23 T. No. 28 En. Wound 16 T. per inch.	11 T. No. 30 En. C. W.	1/4"
40-20	11 T. No. 28 En. 3-32" between turns	9 T. No. 30 En. C. W.	1/4"
20-10	5 T. No. 28 En. 3-16" between turns	7 T. No. 30 En. C. W.	1/4"
Coilform—2 1/4" long by 1 1/4" dia. 4-pin base.			

## Shanghai Calling?

(Continued from page 394)

fare with other forms of radio communication. The receiving set in the wired wireless system would be the same as any ordinary receiver. The antenna post in the receiver should be coupled to the line, over which the transmission is taking place, through a condenser. Don't make any direct connections to telephone or electric light lines. All connections should be made through mica or high voltage condensers because of the danger which may occur if connections are brought out from live wires. We can't say just what the Electric or Telephone Companies will say about this. However, we just mention it as an interesting technical possibility.

# HERE IT IS

SHORT WAVE SET BUILDERS MUST HAVE THIS BOOK

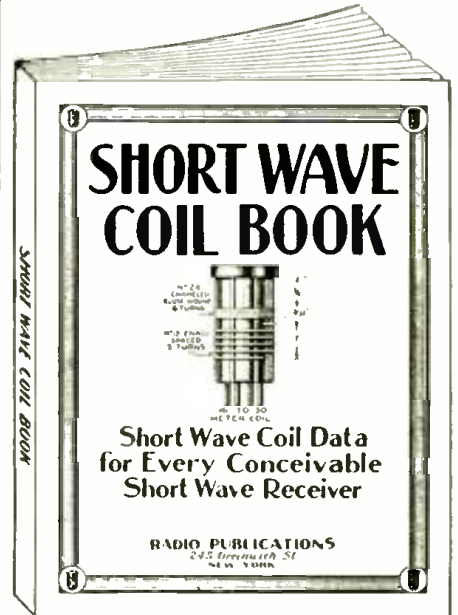

FOR the first time, it is now possible for the experimenter and short wave enthusiast to obtain the most exhaustive data on short wave coil winding information that has ever appeared in print.

As every experimenter who has ever tried to build a short wave set knows only too well by experience, the difference between a good and a poor receiver is usually found in the short wave coils. Very often you have to hunt through copies of magazines, books, etc., to find the information you require. The present data has been gotten up to obviate all these difficulties.

Between the two covers of this book you now find every possible bit of information on coil winding that has appeared in print during the past two years. Only the most modern "dope" has been published here.

No duplication. Illustrations galore, giving not only full instructions how to wind coils, but dimensions, sizes of wire, curves, how to plot them, by means of which any coil for any particular short wave set can be figured in advance, as to number of turns, size of wire, spacing, etc.

There has never been such data published in such easy accessible form as this.

Take advantage of the special offer we are making today, as due to increasing costs, there is no question that the price will increase soon.

**RADIO PUBLICATIONS**  
97 HUDSON STREET  
NEW YORK, N. Y.



Radio Publications,  
97 Hudson Street,  
New York, N. Y.

11-34

Please send immediately, your Short Wave Coil Book, for which I enclose 25c herewith (coin, U. S. stamps or money order acceptable). Book is to be sent prepaid to me.

Name.....

Address.....

City and State .....



**GOLDEN GEM**  
PORTABLE  
ADDING MACHINE



Adds! Subtracts! Multiplies!

Does the Work as Accurately as Machines Selling at \$300.  
OVER 300,000 SOLD THROUGHOUT THE WORLD

The adding machine pictured above is today unquestionably the world's most famous pocket and desk adding machine. Since 1904 this marvelous little "Swiss Watch among Adding Machines", has been purchased by governments, institutions, and individuals the world over.

There is nothing more simple to operate than the GEM adding machine. Numbers are registered on the machine as quickly as they are spoken. All carrying from column to column is done automatically without the slightest attention from the operator. It is this feature, especially, that distinguishes the GEM from all other small adding machines, all of which require the attention of the operator for the carrying process.

Interesting literature and testimonial letters from users all over the country sent upon request.  
Nickel Plated, in bag..... \$ 8.95  
Chrome Finish, in bag..... 9.95  
De Luxe Model in beautiful plush lined case 11.29  
Postage Paid in any part of U. S., Canada and Foreign Countries extra.

**Gold Shield Products Co.**

98 PARK PLACE Dept. S NEW YORK CITY

**Short Wave League Members**

IDENTIFY THEMSELVES WITH THE ORGANIZATION



In order that fellow members of the LEAGUE may be able to recognize each other when they meet, we have designed this button, which is sold only to members and which will give you a professional appearance.

If you are a member of the LEAGUE, you cannot afford to be without this insignia of your membership. It is sold only to those belonging to the LEAGUE and when you see it on another, you can be certain that he is a member.

See Page 445

Lapel Button, made in bronze, gold filled, not plated, prepaid..... 35c  
Lapel Button, like one described above, but in solid gold, prepaid.....\$2.00

**STOPPANI COMPASS**

A Precision Instrument made in Belgium. Purchased by the U. S. Government at more than \$30.00 each. Ideal for Radio Experimenters. Laboratory, also may be used as a galvanometer for detecting electric currents in radio circuits. Ruby, jeweled solid bronze, 4 inches square, fitted in a hardwood case.



Our price prepaid \$4.50 each

**GOLD SHIELD PRODUCTS CO**  
98 Park Place New York City

**Short Wave Scouts**

(Continued from page 403)

- VE9HX—6110 kc.—See card—Halifax, N. S., Canada.
- VE9GW—6095 kc.—See card—Bowmanville, Ontario, Canada.
- W1XAZ—9570 kc.—See card—Springfield, Mass.
- W2XE—6120 kc.—See card—New York, N. Y.
- W2XE—11830 kc.—See card—New York, N. Y.
- W2XE—15270 kc.—See card—New York, N. Y.
- W3XL—6425 kc.—Fridays, 5:30 p.m.—12:30 a.m. New York, N. Y.
- W3XAL—6100 kc.—Saturdays, 5:30 p.m.—12:30 a.m.—New York, N. Y.
- W3XAL—17780 kc.—Daily, 9 a.m.—5 p.m.—New York, N. Y.
- W10XCX—6350 kc.—See letter—Rapids City, S. D.
- W3XAU—9590 kc.—See card—Philadelphia, Pa.
- W3XAU—6060 kc.—See card—Philadelphia, Pa.
- W8XK—6140 kc.—See card—Pittsburgh, Pa.
- W8XK—11870 kc.—See card—Pittsburgh, Pa.
- W8XK—15210 kc.—See card—Pittsburgh, Pa.
- W8XK—21540 kc.—See card—Pittsburgh, Pa.
- W9XF—6100 kc.—See card—Chicago, Ill.
- WLL—17900 kc.—See letter—Rocky Point, N. Y.—R. C. A. Communications.
- WQV—14800 kc.—See letter—Rocky Point, N. Y.—R. C. A. Communications.
- WEA—10610 kc.—See letter—Rocky Point, N. Y.—R. C. A. Communications.
- WEG—10380 kc.—See letter—Rocky Point, N. Y.—R. C. A. Communications.
- WEF—9490 kc.—See letter—Rocky Point, N. Y.—R. C. A. Communications.
- WQO—6725 kc.—See letter—Rocky Point, N. Y.—R. C. A. Communications.
- WEI—8950 kc.—See letter—Rocky Point, N. Y.—R. C. A. Communications.
- W2XBJ—8950 kc.—See Letter—Rocky Point, N. Y.—R. C. A. Communications.
- WKK—21420 kc.—Mornings—Lawrenceville, N. J.—Phone.
- WKF—19220 kc.—Early afternoon—Lawrenceville, N. J.—Phone.
- WNB—10675 kc.—Forenoon—Lawrenceville, N. J.—Phone to Bermuda.
- WNA—9162 kc.—Late evening—Lawrenceville, N. J.—Phone to England.
- WLK—16270 kc.—Mornings—Lawrenceville, N. J.—Phone to England.
- WOA—6755 kc.—Late evening—Lawrenceville, N. J.—Phone to England.
- WOB—6755 kc.—Late evening—Lawrenceville, N. J.—Phone to England.
- WOO—8570 kc.—Early evening—Ocean Gate, N. J.—Phone.
- WOO—4750 kc.—Late evening—Ocean Gate, N. J.—Phone.
- FYA—15243 kc.—Paris, France.
- FYA—11880 kc.—Paris, France.
- FYA—11720 kc.—Paris, France.

(Lack of space does not permit publishing list of unverified stations this month.)

**Trophy Contest Entry Rules**

- THE rules for entries in the SHORT WAVE SCOUT Trophy Contest have been amended and only 50 per cent of your list of stations submitted need be verified. If, for example, you send in a list of 100 stations with 50 verification cards, you will receive credit for the other 50 per cent or 100 stations total. The trophy will be awarded to the SHORT WAVE SCOUT who has logged the greatest number of short-wave stations during any 30 day period; (he must have at least 50 per cent verified) this period need not be for the immediate month preceding the closing date. The complete list of rules appeared in the August issue of this magazine.

In the event of a tie between two or more contestants, each logging the same number of stations (each accompanied by the required 50 per cent verifications), the judges will award a similar trophy to each contestant so tying. Each list of stations heard and submitted in the contest must be sworn to before a Notary Public and testify to the fact that the list of stations heard were "logged" over a given 30 day period, that reception was verified and that the contestant personally listened to the station announcements as given in the list.

Only commercial "phone" stations should be entered in your list. No "amateur" transmitters or "commercial code" stations. This contest will close every month on the first day of the month, by which time all entries must be in the editors' hands in New York City. Entries received after this date will be held over for the next month's contest. The next contest will close in New York City, November 1.

The judges of the contest will be the editors of SHORT WAVE CRAFT, and their findings will be final. Trophy awards will be made every month, at which time the trophy will be sent to the winner. Names of the contesting SCOUTS not winning a trophy will be listed in Honorable Mention each month. From this contest are excluded all employees and their families of SHORT WAVE CRAFT magazine. Address all entries to SHORT WAVE SCOUT AWARD, 99-101 Hudson Street, New York City.

**Build Your Own**   
**Condenser Banks**

For any combination of capacities and voltages . . . compact . . . efficient . . . low in cost . . . most reliable. Simply use Aerovox Uncased Sections. Tape units together. Place in suitable box if desired.



- These uncased sections are the same as those used in standard metal cased filter condensers.
- Non-inductively wound, high-grade dielectric paper. Thoroughly impregnated with high melting point compound for protection against heat.
- Wound and compressed sections dipped in special wax compound to form extra heavy coating to complete protection.
- Minimum bulk for maximum capacity and working voltage, consistent with reliability and long life.

Also ideal, of course, for replacements in any set or power pack. Punctured section can be removed and replaced by one of these uncased sections of corresponding capacity and voltage rating.

Send for Data on these and other Aerovox condensers and resistors. Also free copy of the Aerovox Research Worker—a monthly publication chockful of latest radio dope fresh from research laboratory and engineers.

**AEROVOX**

CORPORATION

72 Washington Street Brooklyn, N. Y.

**Schwartz Leads Again**

- De Forest tubes, types 210, 250, 281...each \$1.00
- Sylvania and Raytheon tubes in stock
- Oscillos 16 to 200 meters, 4 coils to set 1.47
- Na-Alid S.W. Coils, 4 coils to kit: 4 prong 1.77
- Na-Alid S.W. Coil Assembly Selector Unit 2.05
- Wafer sockets: 4 5 6 prong—each 5c; 7 prong .06
- Kurz-Kasch vernier bakelite dials .47
- 8 mfd. elec. condensers, 450 W. volts; card-board .44
- 8 mfd. elec. condensers, 450 W. volts, atom. can .49
- Mershon wet elec. condensers, 18 mfd .29
- Input transformers, I.P. shielded .79
- Power transformers, horizontal mtg. 4 tube .80c; 5 tube, 89c; 6 tube, \$1.30; 7 tube 1.48
- Victor R.F. coils with choke coil attached .07

Distributors of nationally known amateur, serviceman and P. A. System equipment. Write for prices on parts interested.

**M. SCHWARTZ & SON**  
710-712 Broadway  
SCHENECTADY NEW YORK





# "HAM" ADS

Advertisements in this section are inserted at 5c per word to strictly amateurs, or 10c a word (7 words to the line) to manufacturers or dealers for each insertion. Each word in a name and address to be counted. Cash should accompany "Ham" advertisements. Advertising for December issue should reach us not later than October 5.

QSL's 75c A 100 2 COLORS. W9DGH, 1816 5TH Ave. N., Minneapolis, Minn.

SWL's - QSL's, HAM PRINTING, MAC PRINT, 353 1/2 Roland Ave., Baltimore, Md.

SHORT WAVE SETS BUILT TO ORDER cheap. Virgil Darnell, Emerson, Ga.

QSL CARDS, NEAT, ATTRACTIVE, REASONABLY priced, samples free. Miller, Printer, Amherst, Pa.

FOUR TUBE A.C. THREE TUBE BATTERY Short-Wave Receivers, Very Reasonable. Willard Kiesow, Morkan, Minn.

INSULATION, WIRE, VARNISHES, SUPPLIES, etc. Send 3c stamp for bulletin. AUTOPOWER, 414 S. Hoyne Ave., Chicago.

50 WATERS \$7.50 EACH, 211, 203A AND 845, with carbonized plates. Fully guaranteed. Amateur Service, Fairview, N. J.

PHOTO-CELLS - RELAYS - VERY LOW prices, free literature. Pese Scientific Products, 4918 - 13th Ave., Brooklyn, N. Y.

SPECIAL!! A.C.-D.C. SHORT WAVE, Pentode, 2-tube Radio, 3 coils, Wired \$3.50! Tubes \$1.75. Robert Mielke, Ryder, No. Dak.

FAINLESS RADIO MATHEMATICS IN 13 ruler-charts. Batcher's Radiographs sent postpaid for 50c. Robert S. Kruse, Guilford, Conn.

FOR SALE - A RTI RADIO ANALYZER, HAS 3 jewel meters; Very Reasonable. Make offer. Harry Stengel, 224 Findlay St., Cincinnati, Ohio.

IMPROVE SHORT-WAVE RECEPTION WITH simple noise eliminator. Instructions, 15c. Radio, 2224 Woodstock, Pittsburgh (18), Pa.

WANTED - RCA PHOTOPHONE PICKUP OR speakers, wattmeter, etc., meters. Write details. W8FSP, 2095 W. 15th St., Cleveland, Ohio.

2ND EDITION KRUSE'S RADIOPHONE GUIDE, twice as big, completely revised, 2/3 of edition already sold, postpaid 50c. R. S. Kruse, Guilford, Conn.

VARIABLE CONDENSERS - .00035 MFD., PYrex Insulated. Low Loss. Good Condition. 35c each, 4 for \$1.00. W8RW, 208 N. Main, Bluffton, Ohio.

RADIOS - ALL KINDS. DUAL WAVE, AUTO, regular. 11 models. World's cheapest. No-cost sample. Sensation, 20th Century Co., S-3080, K. C., Mo.

SHORT WAVE LISTENER'S CARDS. NEW design, brings results. 100, \$ .75. Also QSL's. Samples Free, Sooooooo, W8ESN, 1827 Cone, Toledo, Ohio.

BLUEPRINT, DATA 18 CRYSTAL SETS - Tubeless; 1850 Mile; Selective; Speaker, 25c Coin. Modern Radiolabs, 151-A Liberty, San Francisco.

PLUG-IN COILS, 15-210 METERS. WOUND on 4-prong tube bases, 30c set. Regular forms, 50c; 6-prong, 75c. Postpaid. NOEL, 809 Alder, Scranton, Pa.

TWO TUBE DOERLE OWNERS! HAVE YOUR set electrified using latest tubes, \$1.50. Satisfaction guaranteed. Others changed accordingly. Virgil Darnell, Emerson, Ga.

KENPLEX - 1 TUBE = 3. KIT, COILS - \$7.00; wired, tested - \$9.00; Diagram - \$2.25; Questions answered - 3 for \$2.25. C. D. Kenyon, 1205 Medical Arts Bldg., Cleveland, Ohio.

WRITE US BEFORE YOU BUY. WE CARRY complete line of used receivers, meters, parts, etc. All good. Prices by return mail. No order too small. Virgil Darnell, Emerson, Ga.

HUMLESS POWER PACKS ABSOLUTELY guaranteed, 250 volts 40 mills, 2.5 volts 3.75 amperes \$4.50, regular \$8.00. Harry Ruske, 1516 West Lehigh Avenue, Philadelphia, Penna.

GOVERNMENT GIVES FREE RADIO OPERATORS training for service on aircraft, ships. Salary, expenses paid. Information booklet, how to qualify, apply, 20c. Federal Equipment Co., Box 344F, Indianapolis, Ind.

BELIEVE IT OR NOT: JAPAN ON LOUD speaker, without antenna or ground. Marvelously sensitive 6 tube receiver. Construction data 35 cents, silver, Morrison, 1263 North New Hampshire, Los Angeles, Calif.

ONE TUBE DX TRANS-CEIVERS \$2.95. Guaranteed, new, and complete; foreign reception, local transmission. Crystal Controlled Transmitters \$3.75 up. Wave Meters only \$1.95. Burks Radio Company, 1444 W. Decatur, Decatur, Illinois.

# "Fringe Howl"

(Continued from page 397)

tone with a high background rush or hiss. This is overcome by increasing the size of the by-pass condenser previously mentioned from .0005 to .01. A .01 will give a very pleasing tone and the signal will sound more natural than with smaller condensers.—H. D. Hooton, WSKPX.

## In Next Issue!

### A REAL S-W "POCKET" RECEIVER

Picked up European Stations in actual tests.

\* \* \*

### SIMPLIFIED RADIO CONTROL

for Model Boats, etc.

\* \* \*

### A LOW-POWER DE LUXE TRANSMITTER

## S. W. and Long Raves

(Continued from page 405)

I've built different sets described in your magazine and find all to work OK. I've built the 3-tube "Signal Gripper", Globe Trotter, the Oscillodyne and a couple more. I'm still using the Oscillodyne; added a 1-tube audio stage, so now it's a 2-tube set and it sure has lots of "pep". Am getting fair DX and amateurs on both phone and 'W' (code).

GEORGE GOULD,

Box 556, Yorkton, Sask., Can.

(Good work, George.—Editor.)

## Health Ray Carbon Lamp



PAYS FOR ITSELF IN A FEW TREATMENTS.

Everyone in the family needs the health giving Violet Rays.

Table Model

Send for interesting literature FREE. List Price with Screen and Goggles, \$10.00.

YOUR COST—F. O. B., N. Y. \$3.38

GOLD SHIELD PRODUCTS CO.

98 PARK PLACE

NEW YORK

SPECIALS—PLUG-IN COILS, 10-200 METERS. Set of Four \$5.00—Forms \$3.08.—R.F. Chokes 2-4-8 Mh. \$20 each. Short Wave maps \$1.00. SWL's \$6.00. 100. Short Wave Accessories, 121 Derby St. Valley Stream, New York.

SHORT-WAVE COILS—SPECIAL COMPLETE set for four short form 50c. Four prong long forms space wound \$1.00. Long six prong \$1.50. Write for prices on Super and Band Spread coils. Sussdorff & Kusterman Radio Laboratories, 297 DeKalb Ave., Brooklyn, N. Y.

OHM'S LAW CALCULATOR—LIGHTNING Slide Rule; solves all problems of Voltage, Current and Resistance. Power, Wire Sizes, etc. Range: 1 micro-amp. to 1000 amps; 1 micro-volt to 10,000 volts; 1 micro-ohm to 10 megohms; 1 micro-watt to 10 megawatts; wire sizes 0 to 36 B. & S. gauge. Introductory price \$1.00 prepaid. The Dataprint Co., Box 322, Ramsey, N. J.

TEN PRACTICAL AND INEXPENSIVE changes converting Dodge 12-V, Ford T.A., Chevrolet Delco 6-V generators, into 100-500 watt capacity A.C. generators, or into 32-110 volt D.C. motor or generator. Dodge is 500-W. self-excited. All in one book illustrated with complete simplified instructions and drawings for only \$1. AUTOPOWER, 414 S. Hoyne Ave., Chicago.



## QUALITY APPARATUS FOR Short Waves

GEN-WIN POLICE AND SHORT WAVE ADAPTER (Convert your broadcast set into a short-wave set tuning from 80 to 200 meters. Get exciting police alarms from stations thousands of miles away. Airplane communications while planes are in flight. Amateur phone and international code communications. The biggest thrill and fun for so little money. Installed in a jiffy. Plugs directly into the detector tube socket. Surely the detector tube in your set, or if uncertain as to detector tube, advise make and model number of set when ordering.

No.	Description	Price
No. 190	for '30, '40, '99, '12A, '200A or '201A Detector Tube	\$1.39
No. 191	for '32 or '34 Detector Tube	1.39
No. 200	for '27, '37 or '56 Detector Tube	1.39
No. 201	for '24, '35, '51, '56, '89 or '44 Det. Tube	1.39
No. 206	for '57, '58, '77, '78, 606 or 616 Det. Tube	1.94



GEN-WIN SHORT WAVE COIL KIT  
The GEN-WIN Short Wave Plug-In coils have stood the test. They have been in great demand for the past three years, and are still selling strongly to the thousands of discriminating experimenters who appreciate the remarkable results they are getting from these excellent coils. The GEN-WIN Short Wave coils can be used in any one of the many circuits published each month in Short Wave Craft magazine. The coils have plate and secondary windings so designed that they will oscillate over the entire short wave band, 15 to 225 Meter with .00014 or .00015 Mfd. Condenser.

ALL-WAVE COIL KIT—Range 25 to 550 Meters  
Comprises a precision wound tuner and R.F. coil, both having tapped secondaries, which permits you to enjoy both SHORT WAVE and BROADCAST PROGRAMS. If you own an Ambassador or any other three circuit tuner receiver, you can easily convert the set into an all-wave receiver, by replacing the coil with these new GEN-WIN ALL-WAVE coils. Coils may be had for use with either .00035 or .0005 Mfd. condenser. Specify which when ordering. Wiring diagram included free with coils. Separately 10c.  
All Wave Tuner (as illustrated)..... 90c  
All Wave R. F. Coil..... 75c  
Send remittance in check or money order.  
Register letter if it contains currency.

## GENERAL WINDING COMPANY

254 W. 31st St. Dept. 11-S NEW YORK, N. Y.

## THE SHORT - WAVE SET YOU ALWAYS WANTED



the "MJ" for the truly critical  
There is no finer Short-Wave Receiver  
Write for details, No. 80-S  
PIONEER SOUND LABORATORY  
135 Liberty St. New York, N. Y.

## Have You Seen the New BROWNIE All-Wave Aerial Kit?

Balanced Doublet System. Anyone can install. Outstanding efficiency in operation. Local noises eliminated. Priced most attractively. Ask your nearest jobber or write us for complete information.  
PORCELAIN PRODUCTS, Inc.  
FINDLAY, OHIO

# 2 new BOOKS on SHORT WAVES

HERE are two brand new books which you have been looking for for a long time. They contain everything that you have been asking for for many months. These new books will give you the latest information of everything you wish to know in two respective fields. Be sure to order them today. You will not regret it.

They make excellent companions to our other handbooks, which you may have.

7" x 10"

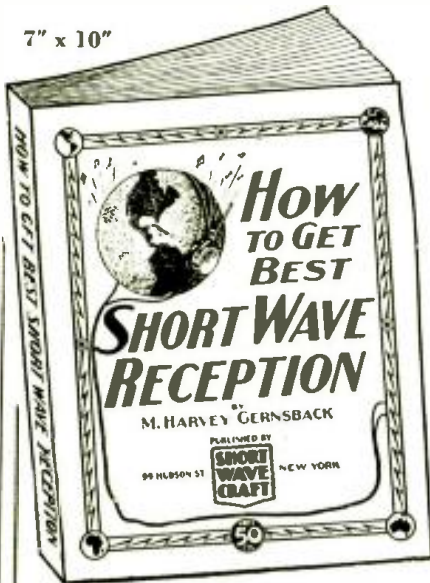

TWO BRAND NEW BOOKS WHICH EVERY ALERT SHORT-WAVE FAN SHOULD HAVE IN HIS LIBRARY

7" x 10"

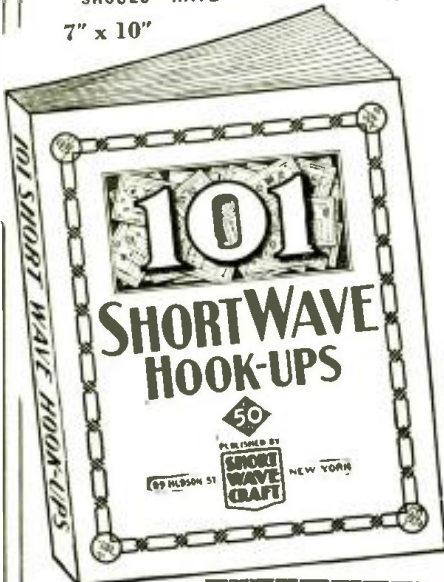

SHORT WAVE CRAFT, 99 Hudson Street, New York City.

Gentlemen: I enclose \$\_\_\_\_\_ for which you are to send to me, postpaid, immediately upon publication, the books checked below:  
 "How to Get Best Short Wave Reception"  
 "101 Short Wave Hookups"

Name \_\_\_\_\_  
 Address \_\_\_\_\_

City and State \_\_\_\_\_  
 (Send check or money order. If you send cash or uncanceled U. S. Postage Stamps, register it.)  
 SWC-11

## "How to Get Best Short Wave Reception"

By M. HARVEY GERNSBACK

Here is a book that gives you everything you have ever wanted to know about short-wave reception. The author, a professional radio listener and radio fan for many years, gives you his long experience in radio reception and all that goes with it.

Why is one radio listener enabled to pull in stations from all over the globe, even small 100 watters, 10,000 miles away, and why is it that the next fellow, with a much better and more expensive equipment, can only pull in the powerful stations that any child can get without much ado?

The reason is intimate knowledge of short waves and how they behave. Here are the chapters of this new book:

1. What are Short Waves and what can the listener hear on a short-wave receiver or converter?
2. How to tune and when to listen in on the short waves.
3. How to identify short-wave stations.
4. Seasonal changes in short-wave reception.
5. Types of receivers for short-wave reception.
6. Aerial systems for short-wave receivers.
7. How to get verifications from short-wave stations.
8. Short-wave hints.

The book is profusely illustrated with the best kind of illustrations that it was possible to obtain.

Please note that this is not a re-hash of anything that has appeared before. Everything in the entire book has been written to order, and there is no duplication of anything here that has appeared in print before.

The book will make excellent reading matter, whether you are a rank beginner or whether you have been at it for a long time. There are many tricks in short-wave reception that even some of the "old-timers" do not know. That is the reason for this book. Be sure to get it. Place your order at once.

72 pages, over 40 illustrations. Price **50c**

## 101 SHORT WAVE HOOKUPS

Compiled by the Editors of SHORT WAVE CRAFT

Here is a worthwhile book that every short-wave listener, every short-wave fan, and every short-wave amateur has wanted for a long time. It gives you the 101 best short-wave hook-ups which have appeared heretofore. It is a veritable encyclopedia of the best in short-waves when it comes to hook-ups.

And do not run away with the idea that we just give you a few plain hook-ups. Each and every hook-up and diagram illustrated is also accompanied by a thorough explanation of what this particular hook-up accomplishes, what parts are required, collating information, values of resistors, etc. In fact, everything you want to know in order to build the set or to look up the data required.

To be sure, all of the important sets which have appeared in print during the past five years are in this valuable book. Sets such as the Doerle, Dinsmore, the "19" Twinplex, Oscillodyne, Duo-Aplidyne, Denton "Stand-by," Megadyne Triplex 2, "Globe-Trotter," 2-Tube Superhet, Almidyne, "Loop" Receiver, "Doerle" 2-tube Battery, "Doerle" 3-tube Battery, "Doerle" 2-tube A.C., "Doerle" 3-tube A.C., Doerle "Signal Gripper," "Control" Band-Spread 2-tube Receiver, 3/4 Meter Portable Transmitter and Receiver, Duo R.F. 4-tube Receiver, The Sargent 9-33 Tapped Coil Receiver, Globe-Gridler 7, The 2-Tube "Champ" — 2 Tubes Equal 3, Ham-Band "2-tube Pee-Wee," Wyezh All-Wave 6, "Hex" Portable Super-het Receiver, The "53" 1-tube Triplex, Stuart Band-Spread S.W. Converter, The "Ace" Band-Spread 3, Denton Economy 3, 2-Tube "Regenerative-Oscillodyne" will be found here, with full descriptions. In many cases, where it was necessary, we have also included a picture hook-up for those who do not wish to follow the regular symbolic hook-up, but wish to have a regular wiring diagram.

Also note, that in many cases, we have not just reproduced old hook-ups or diagrams. In many cases they have been brought up-to-date, to give you the latest information available in such sets.

This is a very handy volume, especially for those "fans" who wish to study the best sets in the short-wave art, from one tube up to ten tubes, instead of leading through a dozen magazines and going through back numbers.

The present volume brings you everything in a clarified manner, leaving nothing to your imagination. The book is thorough, and up to date, and will be a welcome addition to your radio library.

72 pages, over 100 illustrations. Price **50c**

## Which Audio Should I Build!

(Continued from page 407)

utilized. But upon examination of the circuit requirements, it will be found that the triodes available do not have the required gain. Here a pentode type tube can be used triode connected as indicated in Fig. 5. The amplification factor under these conditions will be plus 20 and due to the plate impedance being around 12,000 ohms, standard audio transformers can be used as the coupling medium to the power stage. The frequency characteristic will be governed by the transformer used and the tube will act as a triode in every respect. The bias resistor should have a value of 2,500 ohms and the plate voltage can be between 180 and 300 volts. Any type of audio coupling can be used with this tube as a triode, if resistance-capacity coupling is used a plate loading resistor of 100,000 ohms will be satisfactory. The grid resistor of the following stage can be from 250,000 to 1,000,000 ohms, depending on the tube used.

### A Simple 4 to 6 Watt Amplifier

A new tube known as the 2B6 offers short-wave fans high-power output with low plate voltages. A brief resume of the action of the tube and a study of the circuit diagram of Fig. 7 indicates the possibilities. This tube has good sensitivity and power output and can be used in many receivers in place of 45's, where the improved output will give greater volume with lower signal input levels.

### Average Electrical Characteristics for 2B6

HEATER	
Voltage .....	2.5 volts
Current .....	2.25 ampere

### OPERATING AS CLASS "A" AMPLIFIER INPUT SECTION

Plate (Max.) P1.....	250 volts
Grid G1.....	-24 volts
Plate Current .....	4.0 Ma.
Amplification Factor .....	7.2
Mutual Conductance.....	600 umhos
Plate Resistance.....	12,000 ohms
Load Resistance.....	8,000 ohms
Grid Resistor should not exceed .....	1.0 meg

### OUTPUT SECTION

Plate (Max.) P2.....	250 volts
Grid G2.....	2.5 volts
Plate Current.....	40 Ma.
Amplification Factor.....	18
Mutual Conductance.....	3,500 umhos
Plate Resistance.....	5,150 ohms
Load Resistance.....	5,000 ohms
Signal Volts.....	27 volts
Power Output.....	4.0 watts

Measured between plate and B. Current in cathode lead approx. 3.0 Ma.

Volts r.m.s. for rated power. 5% total harmonic distortion.

### Fundamental Explanation

The new 2B6 embodies two sets of triode elements mounted in tandem, using a common heater but electrically separated cathodes. An examination of Fig. 7 will show the simplicity of the tube and circuit. In this diagram, the left-hand set of triode elements represents the small input; and the right-hand set the large output. The voltage across R0 (Fig. 7) would put this grid at a high positive bias with respect to its cathode. This is nearly off-set by the drop in R1. Thus, the output grid bias is the difference between these two voltages. This bias is normally 2.5 volts positive with respect to its cathode. Therefore, the grid conductance is appreciable, causing the input plate current to divide, part flowing through the output grid resistance and part through R0. Consequently the current for determining the input grid bias should be measured between the input cathode and R0, not between input plate and B—. The average d-c current through this resistor is 3.0 ma. This resistor also forms part of the input section's load resistance, so it must not be shunted by capacitance. The complete load

(Continued on page 444)



# The 4 ESSENTIAL SHORT WAVE BOOKS

'ROUND THE WORLD FANS USE THESE GREAT SHORT WAVE BOOKS

These great books contain everything on short waves that is really worth knowing—they are books which have been most enthusiastically welcomed by short-wave fans. The cost of the books is extremely low in comparison with the valuable material which they contain.

There is not a short-wave fan, experimenter or interested radio-minded reader who will not want these books. Right up-to-the-minute with new material on outstanding developments in the short wave field. The books are authoritative, completely illustrated and not too highly technical.

## Ten Most Popular Short Wave Receivers. How to Make and Work Them

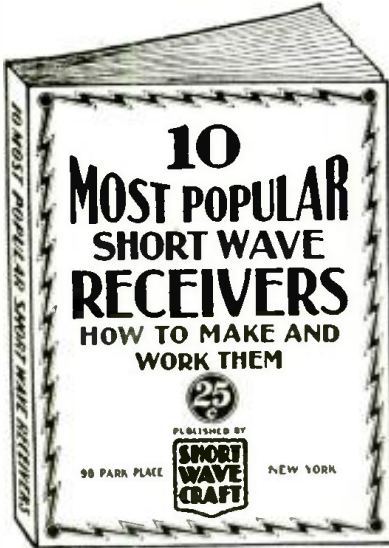

This new volume is a revelation to those who wish to build their own short wave receivers. The editors of SHORT WAVE CRAFT have selected ten outstanding short wave receivers and these are described in the new volume. Each receiver is fully illustrated with a complete layout, pictorial representation, photographs of the set, complete hookup and all worthwhile specifications. Everything from the simplest one tube set to a 5-tube T. R. F. receiver is presented. Complete lists of parts are given to make each set complete. You are shown how to operate the receiver to its maximum efficiency.

### CONTENTS

- The Doerle 2-Tube Receiver That Reaches the 12,500 Mile Mark, by Walter C. Doerle.
- 2-R.F. Pentode SW Receiver having two stages of Tuned Radio Frequency, by Clifford E. Denton and H. W. Secor.
- My de Lute S-W Receiver, by Edward G. Ingram.
- The Binneweg 2-Tube 12,000 Mile 1-X Receiver, by A. Binneweg, Jr.
- Build a Short Wave Receiver in your "Brief-Case," by Hugo Gernsback and Clifford E. Denton.
- The Denton 2-Tube All-Wave Receiver, by Clifford E. Denton.
- The Denton "Stand-By," by Clifford E. Denton.
- The "Stand-By" Electrified.
- The Short-Wave MEGADYNE, by Hugo Gernsback.
- A COAT-POCKET Short Wave Receiver, by Hugo Gernsback and Clifford E. Denton.
- Do They Roll In on this One Tuber! By C. E. Denton.
- The S-W PENTODE-4, by H. G. Cisin, M. E.
- Louis Martin's Idea of A GOOD S-W RECEIVER, by Louis Martin.

25c

## The Short Wave Beginner's Book

Here is a book that will solve your short wave problems—leading you in easy stages from the simplest fundamentals to the present state of the art as it is known today. It is the only low-priced reference book on short waves for the beginner.

The book is profusely illustrated with all sorts of photos, explanations and everything worthwhile knowing about short waves—the book is not "technical." It has no mathematics, no "high-fluting" language and no technical jargon. You are shown how to interpret a diagram and a few simple sets are also given to show you how to go about it in making them.

It abounds with many illustrations, photographs, simple charts, hookups, etc., all in simple language. It also gives you a tremendous amount of very important information which you usually do not find in other books, such as time conversion tables, all about aerials, noise elimination, how to get verification cards from foreign stations, all about radio tubes, data on coil winding and dozens of other subjects.

### Partial List of Contents

- Getting Started in Short Waves—the fundamentals of electricity, Symbols, the Short Hand of Radio—how to read schematic diagrams, Short Wave Coils—various types and tips in making them.
- Short Wave Aerials—the points that determine a good aerial from an inefficient one. The Transposed Lead-in for reduced Man Made Static.
- The Beginner's Short-Wave Receiver—a simple one tube set that anyone can build.
- The Beginner's Set Gets an Amplifier—how the volume may be increased by adding an amplifier.
- How to Tune the Short-Wave Set—telling the important points to get good results.
- Regeneration Control in Short Wave Receivers.
- Audio Amplifiers for S. W. Receivers.
- How to Couple the Speaker to the Amplifier.
- Learning the Code—for greater enjoyment with the S-W set.
- Wave lengths and Motorcycle Chart.
- Wire Chart—to assist in the construction of coils.
- Kinks in the construction of S-W Receivers.

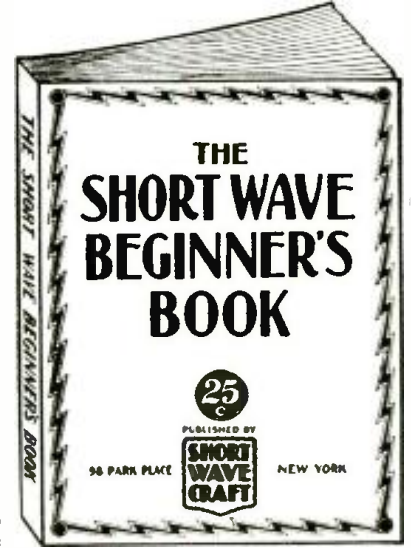

40 PAGES OVER 75 ILLUSTRATIONS

25c

## How to Build and Operate Short Wave Receivers

is the best and most up-to-date book on the subject. It is edited and prepared by the editors of SHORT WAVE CRAFT, and contains a wealth of material on the building and operation, not only of typical short-wave receivers, but short-wave converters as well. Dozens of short-wave sets are found in this book, which contains hundreds of illustrations, actual photographs of sets built, hookups and diagrams galore.

The book comes with a heavy colored cover, and is printed throughout on first-class paper. No expense has been spared to make this the outstanding volume of its kind. The book measures 7 1/2 x 10 inches.

This book is sold only at such a ridiculously low price because it is our aim to put this valuable work into the hands of every short-wave enthusiast. We know that if you are at all interested in short waves you will not wish to do without this book. It is a most important and timely radio publication.

Over 150 Illustrations  
72 Pages 7x10 Inches

50c

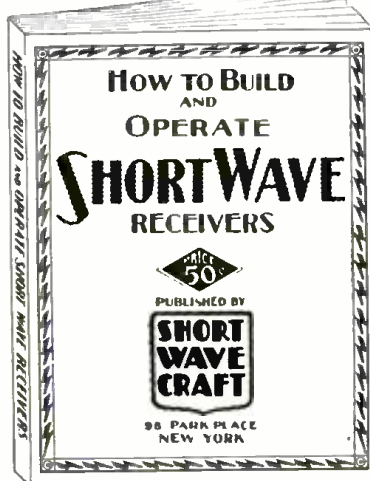

## How to Become an Amateur Radio Operator

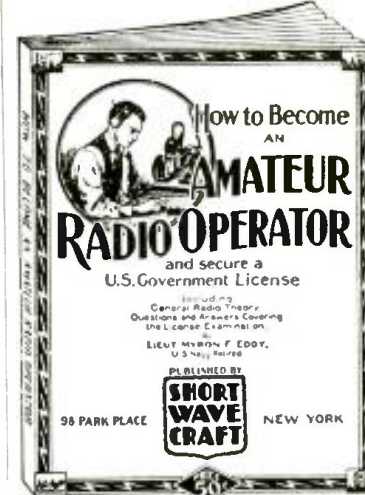

We chose Lieut. Myron F. Eddy to write this book because his long years of experience in the amateur field have made him pre-eminent in the line. For many years he was instructor of radio telegraphy at the U.C.A. Institute. He is a member of the I.R.E. (Institute of Radio Engineers), also the Veteran Wireless Operators Association.

If you intend to become a licensed code operator, if you wish to take up phone work eventually, if you wish to prepare yourself for this important subject—this is the book you must get.

### Partial List of Contents

- Ways of learning the code. A system of sending and receiving with "nerve" drill words is applied so that you may work with approved methods. Concise, authoritative definitions of radio terms, units, and laws, brief descriptions of commonly used pieces of radio equipment. This chapter gives the working terminology of the radio operator. Graphic symbols are used to motivate the various parts of radio circuits. General radio theory particularly as it applies to the beginner.
- The electron theory is briefly given, then waves—their creation, propagation and reception.
- Fundamental laws of electric circuits, particularly those used in radio are explained next and 12 basic circuits are analyzed. Descriptions of modern receivers that are being used with increasing frequency. You are told how to build and operate these sets. Amateur transmitters. Diagrams with specifications are furnished so construction is made easy. Power equipment that may be used with transmitters and receivers, rectifiers, filters, batteries, etc. Regulations that apply to amateur operators. Appendix which contains the International "Q" signals, conversion tables for reference purposes, etc.

Over 150 Illustrations  
72 Pages 7x10 Inches

50c

All the books shown on this page are published exclusively by

**SHORT WAVE CRAFT**

99-101 Hudson Street, New York, N. Y.

CLIP—MAIL

SHORT WAVE CRAFT  
99-101 Hudson Street, New York, N. Y.

Gentlemen: I enclose herewith my remittance for the amount of \$..... for which you are to send me, postpaid, the books checked below.

- Ten Most Popular Short Wave Receivers. How to Make and Work Them. 25c each
- The Short Wave beginner's Book..... 25c each
- How to Build and Operate Short Wave Receivers..... 50c each
- How to Become an Amateur Radio Operator..... 50c each

Name.....  
Address.....  
City..... State.....

(Send remittance in form of check or money order. If letter contains cash or unused U. S. Postage Stamps, register it.)

SW-11-34

These Books are Authentic For All Short Wave Work and LOW in Price

COUPON TODAY!



# WORLD-WIDE RECEPTION WITH THE FAMOUS "TWINPLEX" Short-Wave Receiver

## 2-Sets in-1

**ONE TUBE NOW PERFORMS DUTIES OF TWO TUBES**

SHORT WAVES are the talk of the hour. The whole country, nay, the whole world, has gone crazy to receive foreign stations as far as 12,500 miles distant. Usually such reception is had only with expensive multi-tube sets. Only recently the invention of the "19" tube has made it possible to perform the function of two tubes in a single tube. Then came the invention of the TWINPLEX, a radio circuit of unequal sensitivity, using the "19" tube; it is now possible with a single tube of this type to receive short wave stations from all over the world, loudly and clearly—REGULARLY, night after night, day after day, always in the same place on the dial.

Every radio man knows that in a short-wave set it is highly important to have the wiring as short as possible. By inventing a radically new design, that is, by mounting tube and coils, in fact, everything, on the front panel, it has now been achieved for the first time in a single-tube set. But the TWINPLEX is ACTUALLY A TWO-TUBE SET; yes, we repeat, A FULL-FLEDGED TWO-TUBE SET AT THE PRICE OF A ONE-TUBE SET.

JUST IMAGINE, TWO TUBES IN ONE GLASS ENVELOPE. That is the story of the new "19" tube. It is a 2-volt tube, which has a DOUBLE SET OF ELEMENTS, making it equivalent in every respect to two separate tubes. And not only that, but the current consumption of this tube is so small that a pair of ordinary 1½-volt cells will last for many weeks without replacing them.

This set has been so designed that it will receive ordinary broadcast stations too—stations which come in with great volume, particularly local stations. These come in so loud that if you have a loud speaker this little one-tube set will ACTUALLY GIVE YOU LOUD SPEAKER RECEPTION.

With this set we furnish regularly two coils, one a short-wave and plus-in coil which receives all the popular stations in the 33 to 65 meter band, and a broadcast coil which receives nearly all broadcast stations. A simplified instruction sheet with detailed instructions and pictorial diagrams shows you how to build the set in a few hours' time, and once you have completed the set, FROM THEN ON, YOU DON'T SLEEP ANY MORE.

ONLY FIRST CLASS MATERIAL, such as Hammarlund tuning condensers, Polymet mica condensers, R.M.A. resistors, etc., are employed.

The "19" TWINPLEX is available ONLY in kit form and comprises all parts to properly build the receiver in from one to two hours. ANYONE CAN DO IT. Shipping weight, 5 pounds.

No. SW-308—Famous Twinplex Short-Wave Receiver Kit with all parts, INCLUDING SINGLE HEADPHONE AND BAND, but No Tube. YOUR PRICE \$4.92

No. SW-309—Complete Accessories for TWINPLEX Receiver. Comprising one Type 19 Tube, two No. 6 Dry Cells, two 45-volt "B" Batteries. Ship. weight, 20 lbs. YOUR PRICE \$3.52

See our "Ad" on page 446 for terms. Plug-In Coils for 20, 80 and 160 meter bands. 45c ea. extra



Front View

Get our BIG 108 page catalog. See page 436

Only \$4.92



Rear View of "Twinplex"

Ant

Grnd

A- B- At B+

**RADIO TRADING CO., 101A HUDSON ST., NEW YORK CITY**

**6** Copies of **SHORT WAVE CRAFT** **75¢** PREPAID

For a limited time only, and as long as they last, we will send you six back numbers of **SHORT WAVE CRAFT** assorted, your choice, for 75 cents.

The usual price for six copies would be \$1.50 and most publishers charge a higher price for back numbers over one year old.

We can supply all copies except the following: June-July, Aug.-Sept., 1930; Dec.-Jan., Feb.-Mar., April, May, June, July, Oct., Nov., 1932; Feb., Mar., June, July, 1933.

If you do not specify copies we will use our own judgment in sending assorted numbers to fill your order. Note we cannot exchange the copies for ones that have been sent to you.

Practically every copy of **SHORT WAVE CRAFT** contains important information that you should have. Here is a chance to get those copies.

As we have only a small supply of back numbers on hand, this offer will be withdrawn as soon as they have been sold.

We accept U. S. stamps, U. S. coin, or money order. Rush your order today.

**SHORT WAVE CRAFT**  
99-101 Hudson Street New York, N. Y.

**SHORT WAVE CRAFT** 11-34  
99-101 Hudson Street, New York, N. Y.

Gentlemen: I enclose herewith 75c, for which you are to send me six back number copies of **SHORT WAVE CRAFT** as follows: .....

Name .....

Address .....

City .....

State .....

### Which Audio Should I Build!

(Continued from page 442)

is the parallel combination of R0 and the grid impedance of the output section. Degeneration in resistor R1 is prevented by capacitor C1.

The circuit of Fig. 7 shows the use of this new tube in a "high gain" 4 to 6 watt Audio Amplifier. Some coupling means must be made between the output of the short-wave receiver detector and the input of the amplifier. For circuits to be used in this connection we suggest that you refer to Fig. 6.

The first stage of this amplifier uses a 57 as a voltage amplifier. This in turn is resistance coupled to the input triode section of the 2B6 tube.

There is one interesting point in the power supply unit and that is the use of the 1,500 ohm resistance, as part of the filter unit. This resistance is used in conjunction with two 8 mfd. electrolytic condensers and if it is desired to use a speaker of the dynamic type in conjunction with this receiver, the 1,500 ohm resistor can be removed from the circuit and the speaker field substituted. In the commercial models available, speaker fields having a value of 1,000 to 2,500 ohms can be used quite satisfactorily. However, the best speaker field resistance for this particular circuit would be about 1,800 ohms. As most of the small speakers which should be used with this equipment are supplied with an output transformer, it is not necessary to include such a device in the amplifier chassis, this making the amplifier unit very compact in size. It is important that the .1 mfd. condenser be connected from one end of the power line to the chassis or the B minus ground connection of the various tube and rectifier circuits. This also is the means of grounding off the power supply and minimizing hum. A simple reversal of this plug will provide the most quiet operating conditions. This is one of the most simple forms of "high gain" 4 to 6 watt amplifier.

# It's NOW

## 10¢

EVERYDAY SCIENCE AND MECHANICS is the finest scientific-technical-mechanical-constructional magazine in the field. Up-to-the-minute with news flashes of scientific events. Dozens of constructional articles and many popular experiments. Ideas from which you can make things to sell.

A HOST OF INTERESTING SUBJECTS COVERED:—Aviation—Woodworking—Astronomy—Patents and Inventions—Home Hints—Math—working—Chemistry—Engineering—Microscopy—Electrical Experiments—Lathe Operation—Shop Hints and other subjects.

**\$1.00 FOR ONE YEAR**  
(Canadian and Foreign \$1.50).  
Send Check or Money Order.

**EVERYDAY SCIENCE AND MECHANICS**  
99C Hudson St., New York, N. Y.

Over 150 Illustrations  
10c the Copy On All Newsstands



# SEXOLOGY

THE MAGAZINE OF SEX SCIENCE

SEXOLOGY, foremost educational sex magazine, is written in simple language and can be read by every member of the family. It is instructive, enlightening and a risqué book—contains no offensive matter. Contains 25 important articles on Sex Science, 68 pages, with attractive two-color cover. Here are a few of the more important articles:

Worries About Sex Anatomy—The Truth About Sex Stimulants—Abnormalities of Sex—Can Fear Make a Black Baby?—Sex and Punishment—Is Sex Literature Unwholesome?—Positions of the Uterus—Gonorrheal Stricture—State Care of Syphilis?—Albinos—Ancient Sex Life—Examining the Fallopians—Medieval Childbirth—Sex Violence, or Rape—Scientific Sex Notes—Questions and Answers.

**SEXOLOGY, 95 Hudson St., New York, N. Y.**

Get a copy of SEXOLOGY on any newsstand or if your dealer cannot supply you, send 25c cash or stamps for current issue.



# ••• SHORT WAVE ESSENTIALS

## FOR MEMBERS OF THE SHORT WAVE LEAGUE •••

### A FEW WORDS AS TO THE PURPOSE OF THE LEAGUE

The **SHORT WAVE LEAGUE** was founded in 1930. Honorary Directors are as follows:

Dr. Lee de Forest, John L. Rehnartz, D. E. Replogle, Hollis Baird, E. T. Somerset, Baron Manfred von Ardenne, Hugo Gernsback, Executive Secretary.

The **SHORT WAVE LEAGUE** is a scientific membership organization for the promotion of the short wave art. There are no dues, no fees, no initiations, in connection with the **LEAGUE**. No one makes any money from it; no one derives any salary. The only income which the **LEAGUE** has is from its short wave essentials. A pamphlet setting forth the **LEAGUE'S** numerous aspirations and purposes will be sent to anyone on receipt of a 3c stamp to cover postage.

### FREE MEMBERSHIP CERTIFICATE

As soon as you are enrolled as a member, a beautiful certificate with the **LEAGUE'S** seal will be sent to you, providing 10c in stamps or coin is sent for mailing charges.

Members are entitled to preferential discounts when buying radio merchandise from numerous firms who have agreed to allow lower prices to all **SHORT WAVE LEAGUE** members.

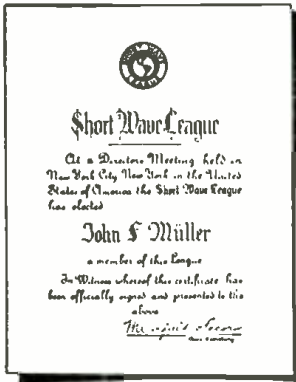

### SHORT WAVE ESSENTIALS LISTED HERE SOLD ONLY TO SHORT WAVE LEAGUE MEMBERS

They cannot be bought by anyone unless he has already enrolled as one of the members of the **SHORT WAVE LEAGUE** or signs the blank on this page (which automatically enrolls him as a member, always provided that he is a short wave experimenter, a short wave fan, radio engineer, radio student, etc.).

Inasmuch as the **LEAGUE** is international, it makes no difference whether you are a citizen of the United States or any other country. The **LEAGUE** is open to all.

### Application for Membership SHORT WAVE LEAGUE

**SHORT WAVE LEAGUE** 11-34 99-101 Hudson Street, New York, N. Y.

I, the undersigned, herewith desire to apply for membership in the **SHORT WAVE LEAGUE**. In joining the **LEAGUE** I understand that I am not assessed for membership and that there are no dues and no fees of any kind. I pledge myself to abide by all the rules and regulations of the **SHORT WAVE LEAGUE**, which rules you are to send to me on receipt of this application.

I consider myself belonging to the following class (put an X in correct space): Short Wave Experimenter  Short Wave Fan  Radio Engineer  Student

I own the following radio equipment:

Transmitting \_\_\_\_\_

Call Letters \_\_\_\_\_

Receiving \_\_\_\_\_

Name \_\_\_\_\_

Address \_\_\_\_\_

City and State \_\_\_\_\_

Country \_\_\_\_\_

I enclose 10c for postage and handling for my Membership Certificate.

### SHORT WAVE LEAGUE LETTERHEADS

A beautiful letterhead has been designed for members' correspondence. It is the official letterhead for all members. The letterhead is invaluable when it becomes necessary to deal with the radio industry, mail order houses, radio manufacturers, and the like; as many houses have offered to give members who write on the **LEAGUE'S** letterhead a preferential discount. The letterhead is also absolutely essential when writing for verification to radio stations either here or abroad. It automatically gives you a professional standing. **50c**

A—**SHORT WAVE LEAGUE** letterheads, per 100.....

### OFFICIAL SHORT WAVE LEAGUE LOG AND CALL MAGAZINE

Here is the finest book of its kind ever published. It contains the largest listing of short wave stations in the world, much larger in fact than the list published in **SHORT WAVE CRAFT** and other magazines. All experimental stations, no matter where located, are listed. A large section is provided where calls can be listed in a proper manner. This log section gives dial settings, time, date, call letters, location, and other information. Another section has squared-paper pages on which you can fill in your own frequency curve for your particular receiver. It helps you to find stations which otherwise you could never log. It is the only book of its kind published. **25c**

B—Official Log and Call Magazine.....Prepaid **25c**

### RADIO MAP OF THE WORLD AND STATION FINDER

The finest device of its kind published. The world's map on heavy board is divided into 23 sections, while the rotary disc shows you immediately the exact time in any foreign country. Invaluable in logging foreign stations. Also gives call letters assigned to all nations. Size 11"x22". **25c**

C—Radio Map of the World and Station Finder.....Prepaid **25c**

### GLOBE OF THE WORLD AND MAGNETIC COMPASS

This highly important essential is an ornament for every den or study. It is a globe, 6 in. in diameter, printed in fifteen colors, glazed in such a way that it can be washed. This globe helps you to intelligently log your foreign stations. Frame is of metal. Entire device substantially made, and will give an attractive appearance to every station, emphasizing the long-distance work of the operator. **1.25**

D—Globe of the World.....Prepaid **\$1.25**

### SHORT WAVE LEAGUE LAPEL BUTTON

This beautiful button is made in hard enamel in four colors, red, white, blue and gold. It measures three quarters of an inch in diameter. By wearing this button, other members will recognize you and it will give you a professional air. Made in bronze, gold filled, not plated. Must be seen to be appreciated. **35c**

E—**SHORT WAVE LEAGUE** lapel button.....Prepaid **35c**

EE—**SHORT WAVE LEAGUE** lapel button, like the one described above but in solid gold.....Prepaid **\$2.00**

### SHORT WAVE LEAGUE SEALS

These seals or stickers are executed in three colors and measure 1 1/4 in. in diameter, and are gummed on one side. They are used by members to affix to stationery, letterheads, envelopes, postal cards and the like. The seal signifies that you are a member of the **SHORT WAVE LEAGUE**. Sold in 25 lots or multiples only. **15c**

G—**SHORT WAVE LEAGUE** seals.....per 25, Prepaid **15c**

### SHORT WAVE MAP OF THE WORLD

This beautiful map, measuring 18x26 in. and printed in 18 colors is indispensable when hung in sight or placed "under the glass" on the table or wall of the short wave enthusiast. It contains a wealth of information such as distances to all parts of the world, political nature of the country in which a broadcast station is located, etc., and from the manner in which the map is blocked off gives the time in different parts of the world at a glance. **25c**

F—**SHORT WAVE** Map of the World.....Prepaid **25c**

### PLEASE NOTE THAT ABOVE ESSENTIALS ARE SOLD ONLY TO MEMBERS OF THE LEAGUE—NOT TO NON-MEMBERS.

Send all orders for short wave essentials to **SHORT WAVE LEAGUE**, 99 Park Place, New York City.

If you do not wish to mutilate the magazine, you may copy either or both coupons on a sheet of paper.

**SHORT WAVE LEAGUE** 99-101 Hudson St., New York, N. Y.



G—15c for 25

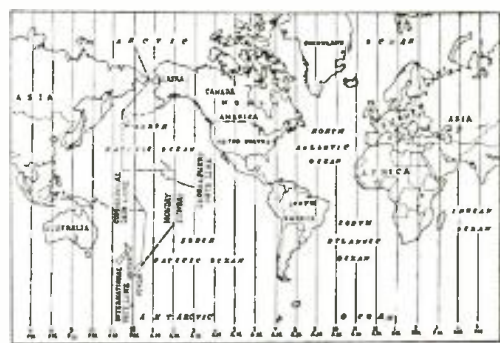

F—25c each



F—25c each

### SHORT WAVE LEAGUE, 99-101 Hudson Street, New York, N. Y.

Gentlemen:

I am already an enrolled member in the **SHORT WAVE LEAGUE**

I am a new member and attach my application to this coupon

Please send me the following short wave essentials as listed in this advertisement

.....

.....

.....

.....

for which I enclose \$ \_\_\_\_\_ herewith (The **LEAGUE** accepts money order, cash or new U. S. Stamps in any denomination. Register cash and stamps)

Name \_\_\_\_\_  
Address \_\_\_\_\_  
City and State \_\_\_\_\_  
Country \_\_\_\_\_

11-34

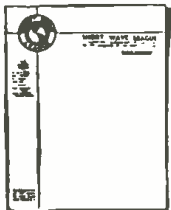

A—50c per 100



B—25c per copy



C—25c each



C—25c each



D—\$1.25 each



E—35c each

# OFFICIAL DOERLE WORLD-WIDE RECEIVERS

## Presenting the Advanced Doerles!—

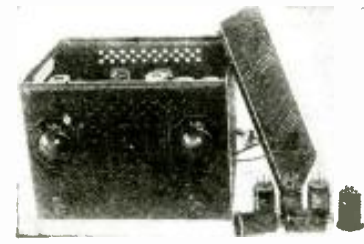

**THE NEW  
Advanced  
"DOERLE  
A.C. Five"  
15 to 200 Meters  
With Built-in  
Dynamic Speaker**

Nothing Else \$26<sup>93</sup>  
to Purchase

Complete—Nothing Else to Buy—15 to 200 Meters.

Well, you Doerle Enthusiasts, isn't this what you've been waiting for? A powerful 5-tube Doerle Receiver, complete with its hum-free power supply and dynamic speaker; all mounted on a single chassis and contained in a beautiful, black, crystalline-finished metal cabinet! Two tuned stages, two A.F. stages with powerful 2A5 output and perfectly matched dynamic speaker; all contribute to the enormous power and superlative performance of this "top notch" of the Doerle line.

During its initial test, in one sitting, this receiver pulled in on its loud speaker, at good room volume, the following variable log: DJD, DUC, and DJA, Germany; JIAA, Japan; GSD and GSC, England; CHX, CJO, and VE9GW, Canada; EAG, Spain; HJABF, Bogota, Colombia; XDA, Mexico; FYA, France; WQO and WEP, testing with the Byrd Expedition and a whole flock of amateurs in practically every radio district of the United States. After that we could no longer keep our eyes open, so we "signed off" to bed.

The receiver employs a 58 as RF amplifier, a 57 as detector, a 56 as first audio amplifier, a 2A5 as power output tube and an 80 as full-wave rectifier. The antenna is coupled inductively to the first tuned circuit through the medium of the three-winding, 6-prong plug-in coils used in the first RF stage. This effectively eliminates the bothersome antenna trimming condenser. Provisions are made for plugging in earphones. The entire set measures, 11 1/2" wide x 8 1/2" deep x 8 1/2" high. Ship. Wt. 19 lbs.

No. 332—The Official "Doerle A.C. Five," self powered, ready to use, complete with tubes, 2 sets of plug-in coils and dynamic speaker, as illustrated. YOUR PRICE ..... \$26.93

- Dynamic Speaker
- 8 Plug-in Coils
- 15 to 200 Meters
- 2 Tuned Circuits

Nothing \$25<sup>23</sup>  
Else to  
Buy

**New  
"DOERLE  
A.C. Four"**



And here's the "understudy" of the DOERLE A.C. FIVE described at the left. This DOERLE A.C. FOUR is, in practically every respect, the same as the Five-Tube Set except that it has one A.F. stage less and uses an external dynamic speaker. Most of the short-wave stations will come in with good volume on the loud speaker. The more distant ones, however, will have to be tuned in with earphones, for which a jack is provided. Its two tuned circuits, together with its single A.F. stage and perfectly matched dynamic speaker, all contribute to the exceptional performance of this receiver.

If you are a regular short-wave fan, you probably know about the world-famous DOERLE 3-TUBE A.C. SIGNAL GRABBER; about its fine performance and about the many thousands of unsolicited testimonials lauding it to the skies. Well, this DOERLE A.C. FOUR is that same receiver, with its special hum-free power supply mounted on the same chassis and all housed in a beautiful, black, crystalline-finished metal cabinet.

The receiver employs a 58 as R.F. amplifier, a 57 as detector, a 56 as first audio and output tube and an 80 as full wave rectifier. The antenna is inductively coupled to the first tuned circuit through the medium of the three-winding, 6-prong plug-in coils used in the first R.F. stage. This effectively eliminates the bothersome antenna trimming condenser. The dynamic speaker connects to the set through a convenient plug and socket arrangement. Provisions are also made for plugging in earphones. The entire set measures, 11 1/2" wide x 8 1/2" deep x 8 1/2" high. Ship. wt. 19 lb.

No. 333—The Official "Doerle A.C. Four," self-powered, ready to use, complete with tubes, 2 sets of plug-in coils and dynamic speaker, as illustrated. YOUR PRICE ..... \$25.23

## The New Competitive Doerle Receivers !



EVER since we brought out our Doerle sets in 1932, unscrupulous competitors have tried to "crash" our legitimate business. They have tried their best to copy the Doerle circuit design and other features of these, now justly famous, sets. They have palmed these sets off as genuine Doerles, and where they could not do so openly, for fear of prosecution from us, they have used various other subterfuges by dubbing their sets as "12,500 Mile Sets", etc.

It should be realized by all that we can produce these sets just as cheaply as the next one IF WE WISH TO SACRIFICE QUALITY. We can use lighter chassis, we can use surplus stock resistors and fixed condensers, and other lower priced materials, but up to now we have consistently refused to do so. We feel, however, that we owe this explanation to our customers, and for those who wish to get lower priced sets we now wish to announce that you can buy them from us too, and AT A LOWER PRICE THAN FROM OUR COMPETITORS. Even at these low prices, however, we could not afford the risk of cheapening the main parts. We still use HAMBURG AND TUNING CONDENSERS and other equally well known components.

And you, the sets we offer here are not as rugged as our standard Doerle sets, on which we never spare and skimp, but if you must have a low-priced set that will do the work, and do it well, here are the sets. These competitive Doerle receivers may be likened to low priced automobiles, as compared with the more expensive ones. Both types will get you places, yet one will outlast the other and will be easier to handle.

### Two-Tube Doerle 12,500 Mile Short-Wave Sets

The excellent performance of these 2-Tube Doerle receivers has already become traditional. Mass production of chassis, the use of good "over-flow" parts from manufacturers and tube-base plug-in coils, makes it possible for us to sell these competitive receivers at the **LOWEST PRICES ON THE MARKET.**

**NO. 349 2-VOLT BATTERY MODEL DOERLE KIT**  
This receiver uses 2 of the new economical 30 tubes. Batteries required are 2 No. 6 dry cells (or a 2 volt storage cell) and 2.45 volt "B" batteries. Sold complete with instructions and diagram. Shipping weight 5 lbs.  
YOUR PRICE, Less Tubes ..... \$4.60

Pair of Matched 30 Tubes ..... \$1.30

**NO. 350 ALL-ELECTRIC A.C. DOERLE KIT**  
This model requires no battery or power pack at all. It works anywhere and on any type of current at 110 volts. Has a self-contained power supply. Uses 3 type 37 tubes. Shipping weight 8 lbs.  
YOUR PRICE, Less Tubes ..... \$6.60

Three Matched 37 Tubes ..... \$1.85

**NO. 351 STRAIGHT A.C. DOERLE KIT**  
This model uses either 2 50's or 2 27's. It may be used in conjunction with our own power pack, listed below. The set may also be run on a 2 1/2-volt filament transformer or a "B" eliminator or, instead of the "B" eliminator, 2 45-volt "B" batteries. Shipping weight 6 lbs.  
YOUR PRICE, Less Tubes ..... \$4.60

Pair of Matched 56 or 27 Tubes ..... \$1.30

**NO. 352 COMPETITIVE A.C. POWER PACK KIT**  
A compact power unit delivering 2 1/2 volts at 1.5 amps for filament supply and 250 volts D.C. at 50 ma for plate supply. Requires a type 80 as rectifier.  
YOUR PRICE, Less Tubes ..... \$4.70

Rectifier Tube ..... \$ .40

WE WILL WIRE AND TEST ANY OF THESE KITS WHEN ORDERED FOR \$1.25

Lowest Price **\$4.60**

### The Fultone II



This receiver takes advantage of the new screen grid and power pentode tubes which impart to it greater sensitivity and greater volume. Uses a 32 screen grid tube as detector and a 33 tube as power pentode output. Both of these tubes are of the 2-volt type requiring 2 No. 6 dry cells (or a 2 volt storage battery cell) for operation. The receiver is complete with plug-in coils covering the range of from 15 to 200 meters. All parts are mounted on a metal chassis and contained in a black crystalline metal cabinet. The receiver is extremely simple to operate and very stable. It is an ideal set for the beginner. Shipping weight 9 lbs.

**NO. 353 FULTONE II RECEIVER KIT** ..... **\$5.60**

YOUR PRICE .....  
Set of Matched Tubes ..... \$1.75  
Set of Batteries, including 2 No. 6 Dry Cells and 2 45-Volt "B" Batteries ..... \$2.56

**ORDER FROM THIS PAGE** Send money order or certified check. C.O.D. only if 20% remittance accompanies all orders. Order NOW—TODAY.

**FREE** 108-page Radio and Short Wave Treatise; 1,000 illustrations. Enclose 5c U.S. stamps or coin for postage. Book sent by return mail. Print name and address on your request.

**RADIO TRADING CO., 101A HUDSON ST., NEW YORK CITY**



**• Index to Advertisers •**

**A**

Ace Radio Laboratories.....425  
 Aerovox Corporation.....439  
 Alan Radio Corporation.....430  
 Alden Products Co.....431  
 Allied Engineering Institute.....434  
 Allied Radio Corporation.....436  
 Amplivox Laboratories.....435  
 Arco Tube Company.....447

**B**

Blair the Radio Man, Inc.....430  
 Biley Electric Company.....429  
 Breakers, Hotel.....430  
 Bud Radio, Inc.....424

**C**

Candler System Co.....438  
 Centrallion Engineering Co.....435  
 Coast-to-Coast Radio Corp.....437  
 Constructrad, Inc.....435  
 Coyne Electrical School.....387

**D**

Dataprint Company.....429, 437  
 Dodge's Institute.....434

**E**

Eastern Radio Specialty Co.....432  
 Eilen Radio Laboratories.....437  
 Everyday Science & Mechanics.....444  
 Experimental Radio Labs.....429

**F**

First National Television, Inc.....436

**G**

General Engineering Corp.....426  
 General Winding Co.....441  
 Goldentone Radio Company.....434  
 Gold Shield Products Co.....426, 439, 441

**H**

"Ham" Advertisements.....441  
 Hammarlund Manufacturing Co.....431  
 Harrison Radio Company.....425  
 Hygrade Sylvania Corporation.....433

**I**

Instructograph Company.....424

**K**

Korrol Mfg. Co., Inc.....424

**L**

Lancaster, Allwine & Rommel.....433  
 Leotone Radio Co.....430  
 Lynch, Arthur H., Inc.....433

**Mc**

McGraw-Hill Book Company, Inc.....436

**M**

Midwest Radio Corp.....Back Cover  
 Mueller Electric Co.....427

**N**

National Company, Inc.....Inside Back Cover  
 National Radio Dist. Co., Inc.....433  
 National Radio Institute.....Facing Inside Front Cover  
 New York YMCA Schools.....430

**P**

Pioneer Sound Laboratory.....441  
 Popular Medicine.....436  
 Porcelain Products, Inc.....441  
 Postal Radio Corp.....433

**R**

Radio Craft Magazine.....436  
 Radio Publications.....440  
 Radio Trading Co.....428, 432, 436, 444, 446  
 RCA Institutes, Inc.....426  
 RCA Radiotron Co.....Inside Front Cover  
 Remington-Rand, Inc.....432

**S**

Schwartz, M., & Son.....439  
 Sexology Magazine.....444  
 Shortwave & Television Corp.....438  
 Short Wave Coil Book.....438  
 Short Wave League.....445  
 Short Wave Radio Manual.....388  
 Sprague Products Co.....435  
 Supertone Products Corp.....428  
 Supreme Instruments Corporation.....385

**T**

Telex Co.....425  
 Thor's Bargain Basement.....426  
 Trimm Radio Mfg. Co.....438  
 Try-Mo Radio Co., Inc.....424, 427

**U**

Uncle Dave's Radio Shack.....429

**W**

Wellworth Trading Company.....434  
 Wholesale Radio Service Co., Inc.....423

(While every precaution is taken to insure accuracy, we cannot guarantee against the possibility of an occasional change or omission in the preparation of this index.)

**3.1 Meter Receiver**

(Continued from page 408)

and Ig a single turn, both of the coils having a diameter of .8 inch and when the variable condenser C1 has a maximum value of about 65 mmf. The connections are naturally made as short as possible. The practical construction of the receiver is shown in Fig. 14. The grid leak R1 equals 2 megohms. The R.F. choke CH has a total of 100 turns and is wound in groups in the manner of the R.F. choke CHB of the transmitter (Fig. 8). The fear that a plain choke is here not sufficient and that probably a filter system for the R.F. currents would be required, appeared to be without foundation.

Disturbances in the A. F. amplifier due to "sneaking in" of radio frequency currents were not observed. The R.F. choke CH is connected over the primary of the A.F. transformer Tr (1:4 ratio), which is in series with the adjustable resistor, R2, equal to 50,000 ohms and the coil L2 of the local oscillator to the common plate voltage, plus Va12 of both tubes V1 and V2. (C2 equals .005 mf.; C3 equals 1 mf.) The local oscillator tube V2 is of the 112 type. Of the two honeycomb coils used in the local oscillator, L1 has 5000 turns and L2 250 turns; C4 equals .001 mf. The coils are mounted in an adjustable coil holder and the spacing between them can be varied within large limits. Thus the amplitude of the generated A.C. can be adjusted for the maximum sensitivity. The A.F. circuit is of the normal type; R3 equals .1 megohm.

Care must be taken in building this receiver to have the connections of the regenerative circuit as short as possible. Fig. 14 shows the photograph of the receiver built by the author. The regenerative tube is mounted vertically. Next to its left is the condenser Cn. The coils L4 and Lg which are made of silvered copper wire, are mounted on a little bridge and just below this one is located the variable condenser C1.

(To be concluded.)

**Stop Graying Hair**

(Continued from page 393)

job was wired, you could see no faults. . . . you were ready to tune in the world!

Now for a try at that Circuit of Errors nearby, for your solution of what's wrong. How many mistakes can you find in it? There are seven—at least seven!

**THE ERRORS IN DIAGRAM :**

- Bottom of grid coil should go to GND.
- Grid coil should be the larger.
- Should have by-pass cond. (1/4 or 1/2 mf.) between B PL'S and filament.
- Tuning cond. rotor (arrow) should go to GND.
- .00025 mf. cond. should go to GND.
- Grid leak should be shown as resistance, not inductance.
- Grid cond. should be .0001, not .01 mf.

**What British Are Doing With 5 Meters**

(Continued from page 394)

and conditions and some day it may lead to the solution of whether or not certain types of hills which exist between transmitting and receiving stations are beneficial or detrimental. We have seen cases where a hill between the transmitting and receiving station was a decided benefit. This, of course, is contrary to the popular belief. We know of one particular case where 65 miles was covered with a fairly low-powered 5-meter transmitter and over this distance four or five ranges of high mountains exist. So far, there are two groups of critics. Some say that the hills are detrimental and others say they are not. We hope that in the near future accurate tests will prove either one or the other to be true and do away with this controversy. — Courtesy "Wireless World".

**NEW Reduced Prices on ARCO Tubes**

HIGHEST QUALITY BUILT INTO ARCO TUBES

Our Sales Policy Is: First Quality Merchandise, Rapid Service, Low Price, and a Square Deal. All Tubes are—

- 1—GUARANTEED FIRST QUALITY
- 2—R.C.A. LICENSED
- 3—FULLY REPLACEABLE UNDER R.M.A. STANDARD POLICY
- 4—UNIFORMLY WITHIN R.C.A. TEST LIMITS
- 5—ATTRACTIVELY PACKED

**Complete Stock Ready for Immediate Shipment**  
 Order from this page—Remit 25% with order, balance C. O. D. All prices are F. O. B. FACTORY, Newark. Shipments go forward express or parcel post. No order for less than \$3.00 accepted.

Type No.	Fil. Voltage	Your Cost	Type No.	Fil. Voltage	Your Cost
1V	6.3	.50	75	6.3	.50
00A	5.0	.40	76	6.3	.45
01A	5.0	.30	77	6.3	.50
10	7.5	1.10	78	6.3	.50
12A	5.0	.40	79	6.3	.60
19	2.0	.60	80	5.0	.35
20	3.3	.40	81	7.5	1.10
22	3.3	.60	82	2.5	.45
24A	2.5	.45	83	5.0	.50
26	1.5	.30	84	6.3	.50
27	2.5	.30	85	6.3	.50
30	2.0	.45	89	6.3	.50
31	2.0	.45	X199	3.3	.45
32	2.0	.60	V199	3.3	.45
33	2.0	.60	1A6	2.0	.85
34	2.0	.60	1C6	2.0	.85
35/51	2.5	.50	2A3	2.5	.85
36	6.3	.50	2A5	2.5	.60
37	6.3	.40	2A6	2.5	.60
38	6.3	.50	2A7	2.5	.60
39/41	6.3	.50	2B6	2.5	1.10
40	5.0	.40	2B7	2.5	.60
41	6.3	.50	5Z3	5.0	.50
42	6.3	.50	6A4/LA	6.3	.60
43	25.0	.50	6A7	6.3	.70
45	2.5	.35	6B7	6.3	.60
46	2.5	.50	6C6	6.3	.60
47	2.5	.50	6D6	6.3	.60
48	30.0	1.10	6F7	6.3	.70
49	2.0	.50	12A5	6.3	.85
50	7.5	1.10	12Z5	6.3	.85
53	2.5	.60	25Z5	25.0	.60
55	2.5	.50	12Z3	12.6	.50
56	2.5	.35	PZH	2.5	.85
57	2.5	.50	WD11	1.1	.85
58	2.5	.50	WD12	1.1	.85
59	2.5	.60	216B	7.5	.85
71A	5.0	.30	213	5.0	.60

**• SPARTON TYPE TUBES •**

182B	5.0	.60	485	3.0	.85
183	5.0	.85	586	7.5	1.75
484	3.0	.60	686	3.0	.85

**• KELLOGG TYPE TUBES •**

101	3.0	1.50	403	3.0	2.00
-----	-----	------	-----	-----	------

**• MAJESTIC TYPE TUBES •**

2A7S	2.5	1.10	6Z5	6.3	.85
2B7S	2.5	1.10	248	2.5	.60
2S4S	2.5	1.10	25/25S	0.2	1.10
2Z2 (84)	2.5	.85	27S	2.5	.50
6A7S	6.3	1.10	35S/51S	2.5	.75
6B7S	6.3	1.10	55S	2.5	.85
6C7	6.3	.85	56S	2.5	.60
6D7	6.3	.85	57S	2.5	.85
6E7	6.3	.85	58S	2.5	.85
6F7S	6.3	.85	75S	6.3	.85
6Y5	6.3	.85	85S	6.3	.85
6Z4	6.3	1.10			

**• RECTIFIER AND CHARGER BULBS •**

125 Mill. rectifier tube B.H. (Raytheon type).....	\$1.25
6-10 Amp. trickle charger bulb (Tungar type).....	2.00
2 Amp. charger bulb (Tungar type).....	2.00
5 and 6 Amp. charger bulb (Tungar type).....	3.75
15 Amp. charger bulb (Tungar type).....	7.50
UX-280M—3.0 Full Wave Mercury Vapor Rectifier.....	1.10
UX-281M—7.5 Half Wave Mercury Vapor Rectifier.....	1.90
UX-866—2.5 Half Wave Mercury Rectifier.....	2.75
UX-871—2.5 Half Wave Mercury Vapor Rectifier.....	1.10
UX-872—7500 Volts Half Wave Merc. Vap. Rec.....	11.00

**TELEVISION TUBES AND PHOTO ELECTRIC CELLS**

Photo Cell (Potassium), 2 1/2" Length Overall.....	\$1.75
Photo Cell (Potassium), 3 1/2" Length Overall.....	2.10
Photo Cell (Caesium Type), 4 1/2" Length Overall.....	7.90
Photo Cell (Caesium Type), 3" Length Overall.....	5.90
Photo Cell (Caesium Type), Same as UX 868.....	4.90
Television Tube (Neon Reflector), 1" Sq. Cathode.....	2.85
Television Tube (Neon), 1" Sq. Cathode.....	2.85
Television Tube (Neon), 1 1/2" Sq. Cathode.....	3.85

Specifications and quotations on TRANSMITTER TUBES, CRATER TUBES, GLOW LAMPS, HIGH VACUUM TYPE CATHODE RAY TUBES, suitable for television and standard oscillographic uses, SUBMITTED ON REQUEST.

**ARCO TUBE COMPANY**  
 232 Central Avenue Newark, N. J.

# WORLD GLOBES

FOR SHORT WAVE ENTHUSIASTS

## AT UNPRECEDENTED LOW PRICES

THESE remarkable globes, executed in fourteen colors, are absolutely indispensable for short wave fans. Notable among the numerous features of these world globes, is that a damp cloth quickly removes all dust and water does not harm the surface.

Short Wave fans are enabled to determine correct time in various centers of the world with the aid of these maps; distances from city to city can be accurately established.

There is a graduated "Meridian" scale of black enameled metal with the 9" and 12" globes. An additional feature is the movable hour scale found at the north pole—this facilitates determining the hour in any part of the world.

Only on a globe of this size is it possible to get an accurate picture of countries and their relative positions to each other. You will actually be amazed when you compare distances—from New York to Moscow from Cape Town to Tokio; from Los Angeles to Rio de Janeiro, etc. A flat map is deceptive for measuring, but take a small string and stretch it across the globe, from city to city, and you have the correct distances.

Here are globes that add dignity to home, office, studio or laboratory—a globe that everyone would be proud to possess.

Each world globe contains a listing of over 7,500 cities in nations the world over—spellings conform to international geographic standards—all globes are of 1934 production. GET ONE OF THESE FINE WORLD GLOBES TODAY!



**World Globe No. 147**

12" Globe. New model—equipped with wooden floor stand finished in walnut. Height overall 35". Globe constructed with half meridian. New World Globe Handbook included FREE. A marvelous buy. Never has a floor model Globe been sold at such a low price. Shipping weight 9 lbs.

PRICE  
**\$4.15**

F.O.B. Chicago.

**World Globe No. 99**

9" Globe, equipped with sturdy, black metal base and full meridian. Same ball as our No. 139 but reduced 1/4 in size and scale. Included with globe is newly printed World Globe Handbook FREE. Shipping weight 6 lbs.

PRICE  
**\$2.05**

F.O.B. Chicago.



Gentlemen:

I received the World Globe and am certainly well pleased with its completeness, appearance and its usefulness. Short wave listening has become a hobby with me, and this World Globe is a necessary accessory to any short wave listener or, for that matter, to any home.

P. C. ELLIS, Supt.  
Laboratory—19th and Campbell Streets, Kansas City, Mo.



**World Globe No. 47**

7" Globe, equipped with sturdy metal base and half meridian. Index to countries to the world by latitude and longitude shown on base. Shipping weight 2 lbs. PRICE

**\$0.90**

**World Globe No. 139**

12" Globe, equipped with sturdy, black metal base and half meridian. Contains over 7,500 names and cities. Spellings conform to authoritative world standards. Hundreds sold to many short wave fans during the last year. Copy of World Globe Handbook included FREE. Shipping weight 8 lbs. PRICE

**\$3.25**

F.O.B. Chicago.



All globes are carefully packed in original cartons assuring safe delivery. ORDER BY NUMBER. Send check or money order, plus warehouse. Register letter if it contains cash, or currency or stamps. If preferred, specify that shipment be sent express collect. ALL ORDERS ARE FILLED PROMPTLY.

ALL GLOBES SHIPPED IMMEDIATELY

**ORDER YOUR GLOBE TODAY!**

SHORT WAVE CRAFT

59 Hudson Street, New York, N. Y. SWC-11-34  
Gentlemen: Enclosed you will find my remittance of \$..... for which please ship me the following World Globe.

- World Globe No. 99 @ \$2.05
- World Globe No. 147 @ \$4.15
- World Globe No. 47 @ \$0.90
- World Globe No. 139 @ \$3.25

Name .....

Address .....

City ..... State .....

Send remittance in check or money order—register letter if it contains cash, stamps or currency. GLOBES ARE SHIPPED FROM OUR WAREHOUSE IN CHICAGO—F. O. B. FROM THAT CITY.

**SHORT WAVE CRAFT**

**99 HUDSON STREET,  
NEW YORK, N. Y.**



# NATIONAL RADIO PRODUCTS



Shown below are a few representative examples of National Radio Products. The list prices given are subject to 40% discount when purchased through an authorized NATIONAL CO. distributor. National Velvet Vernier Dials, Transmitting and Variable Condensers, R. F. Chokes, Amateur Receivers (SW-3, SW-58 and 34, FB-7A, FBX-A, AGS and AGSX), Short Wave Power Units, and Short Wave Accessories are built to strictly maintained standards of precision and workmanship, and are universally used in Short Wave and Amateur Radio. The full line is described and priced in our new and complete Bulletin No. 220. Write for your copy today, enclosing 6c to cover mailing costs.

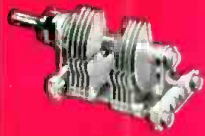

**STD Midget Condenser**  
Double condenser, 180° SLW plates, 50 mmf. per section. Air gap, .026. Isolantite insulation. Constant impedance rotor connection, insulated front-bearing. List price **\$3.50.**



**Type "N" Dial**  
Solid German silver 4" precision dial with original and matchless Velvet Vernier mechanism. Machine divided scale and vernier read to 1/10th division. Ratio 5-1. List price **\$6.75.**



**Air-Dielectric Condenser-Tuned IF Transformer**  
Standard in National FB-7A and FBX-A Amateur Receivers. 450 to 550 kc. tuning range. Also made in 175 kc. model. List price ea. **\$5.**

**STN Midget Condensers**

For neutralizing 245, 247, 210 and similar tubes in amplifier, buffer or doubler stages. Isolantite insulation. Max. cap. 18 mmf. 3000 v. breakdown. List price **\$2.00.**



**SEH Midget Condenser**  
Like half of 2SE Condenser but with more plates and air gap of .0175. Caps. 200, 250, 300 and 335 mmf. List prices (respectively) **\$3.75, \$4., \$4., \$4.25.**



**2-SE Midget Condenser**  
Isolated rotors, electrically independent, prevent interstage coupling through common rotor and frame circuits. Isolantite insulation. 270° SFL plates. 100 mmf. per sect. Air gap .026. List price **\$5.00.**



**Air-Dielectric Padding Condenser**  
Shielded air-dielectric padding-condenser on Isolantite base. In 75 and 100mmf. max. capacities. Extremely compact. List price (respectively), **\$2 and \$2.25.**



**NATIONAL Sockets**  
National Isolantite Sockets reduce socket losses to a minimum. Made in either 4, 5, 6 or 7-prong styles and also special 6-prong for National coils. Ea. **\$1.60.**



**Type B Dial Velvet-Vernier**  
The smooth, National Velvet-Vernier Drive is positive and free from back-lash. Variable ratio 6-1 to 20-1. Horizontal diameter 4". List price (without illuminator) **\$2.75.**



**Stand-off Insulator**  
Isolantite insulator with 3-point mount and 6/32 screw on top. For carrying high tension leads, mounting transmitter inductances, etc. List price, ea. **\$1.25.**



**Low Frequency Oscillator Coils**  
Contains two separate inductances closely coupled within a shield, as used in the National Type SRR 56 MC Super-regenerative Receiver. List price OSR **\$1.50.**

**FB-7A Coil Form**

Made of R-39, special low-loss dielectric. Complete with grounded metal end handle, air-dielectric padding-condenser, and protective sleeve. List price each **\$3.65.**



**SEU Midget Condenser**  
Heavy, double-spaced, polished, round edge, 270° SFL plates. Air gap .055. Isolantite insulation. 15, 20 and 25 mmf. capacities. List prices (respectively) **\$2.50, \$2.75, \$2.75.**



**Standard R-39 Coil Forms**  
Made of R-39 ultra low loss form material, for National SW-5, SW-45, SW-34, SW-3, and SW-58 Receivers. In 4, 5 or 6-prong bases, list price each **\$1.75.**



**Midget R-39 Coil Forms**  
For ultra HF use. Have best form factor and lowest RF resistance. 1" diam. 1 1/2" long, 1/16" wall. Unwound and ungrooved. List price ea. **\$1.50.**



**ET Equitune Condenser**  
The original National "girder frame" condenser. Modified 180° plates. Caps. 150 to 500 mmf. Air gap .023. List prices **\$4.25 to \$5.**



**EMP Condenser**  
Split-stator condenser for receivers and low power push-pull transmitters. 1200 v. breakdown. Air-gap, .023. Standard size 100 mmf. per section. List price **\$5.00.**



**NATIONAL Coil Cabinet**  
For storage and protection of coils. Heavy gauge brown moiré finished steel in two sections, closing to form a cabinet: 9" x 8" x 5". List price **\$3.75.**



**Frequency Meter Condenser**  
For Amateur Frequency Meters and Monitors. Special circular rotor plates permit use of High C Circuit. Min. cap. 40 mmf. Max. cap. 75 mmf. List price, **\$5.50.**



**NATIONAL GridGrip**  
For attaching a wire to the screen grid terminal of AC or DC tubes. Never works loose, permanent contact. For broadcast set tubes, list price, ea. **\$1.05;** for large tubes like 872, list price ea. **\$1.10.**



**Type R-152. RF Choke**  
Continuous universal winding in 5 sections on 10,000 v. Isolantite insulation. Ind. 4 m.h. Distrib. cap. 1 mmf. DC Res. 10 ohms; continuous rating 0.6, intermittent 0.8 amps. List price **\$2.25.**



**EM Equimeter Condensers**  
For low powered transmitters and oscillators 1000v. and under. 180° SLW plates. Isolantite insulation. Air gap .023. Caps. 50 to 1000 mmf. List prices (without dials) **\$2.50 to \$5.50.**

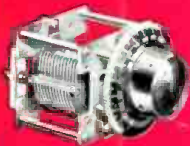

**Type 90 RF Choke**  
For by-passing work on screen grid or plate circuits of screen grid tubes or between detector and first audio. DC res. 350 ohms. Ind. 90 m.h. List price without mount, **\$1.25.**



**Type 100 RF Choke**  
Isolantite mounting, continuous universal winding in 4 sections. Ind. 2 1/2 m.h. Distrib. cap. 1 mmf. DC res. 50 ohms. 125 ma. List price each **\$1.75.**

**NATIONAL COMPANY, INC., MALDEN, MASSACHUSETTS**





THOUSANDS ARE *Enthusiating* OVER THE *NEW*

1935 MIDWEST-16

Thrill to **UNEQUALLED** and **GUARANTEED** World-Wide Performance with this—

Amazing New **MIDWEST 1935 SUPER Deluxe**

**16-TUBE ALL-WAVE Radio**



**9 TO 2,400 METERS (12,000 MILE TUNING RANGE)**

**WORLD'S GREATEST RADIO VALUE**  
**\$57.50** with New **Deluxe Auditorium-Type SPEAKER**  
 ... LESS TUBES ...

**TERMS AS LOW AS \$5.00 DOWN**

OVER 110,000 SATISFIED CUSTOMERS SAVED 1/3 TO 1/2 BY BUYING DIRECT World-Wide Entertainment

**30 DAYS FREE TRIAL**

**BEFORE** you buy any radio, write for **FREE** copy of the new 1935 Midwest "Fifteenth Anniversary" catalog. See for yourself the many reasons why over 110,000 satisfied customers have bought their radios direct from Midwest Laboratories . . . and saved from 1/3 to 1/2. Learn why Midwest radios out-perform sets costing up to \$200 and more.

**NEVER BEFORE SO MUCH RADIO FOR SO LITTLE MONEY** You, too, can make a positive saving of from 30% to 50% by buying this more economical way. Why be content with ordinary "Dual Wave," "Tri-Wave," or so-called "All-Wave" receivers when Midwest gives you more wave lengths in today's most perfectly developed 16-tube Super De Luxe ALL-WAVE radios that are proven by four years of success . . . that carry an iron-clad guarantee of foreign reception! These bigger, better, more powerful, clearer-toned, super-selective radios have **FIVE** distinct wave bands: Ultra-short, short, medium, broadcast and long. Their greater all-wave tuning of 9 to 2400 meters (33 megacycles to 125 KC) enables you to tune in stations 12,000 miles away with clear loud-speaker reception. Write today for new **FREE** catalog.

**NOW ENJOY DX-ING HOBBY**

Now, you can enjoy super American, Canadian, police, amateur, commercial, airplane and ship broadcasts . . . and derive new delight and new excitement from unequalled world-wide performance. Now, you can enjoy the DX-ing

hobby and secure verifications from some of the world's most distant stations. Thrill to the chimes of Big Ben from GSB, London, England . . . tune in on the "Marseillaise" from FYA, Pontoise, France . . . hear sparkling music from EAQ, Madrid, Spain . . . delight in lively tangos from YVIBC, Caracas, Venezuela . . . listen to the call of the Kookaburra bird, from VK2ME, Sydney, Australia, etc. Send **TODAY** for money-saving facts.

**DEAL DIRECT WITH LABORATORIES**

Increasing costs are sure to result in higher radio prices soon. Buy before the big advance . . . **NOW** . . . while you can take advantage of Midwest's sensational values . . . no middle-men's profits to pay. You can order your radio from the new Midwest catalog with as much certainty of satisfaction as if you were to select it in our great radiolaboratories. You save 30% to 50% when you buy direct this popular way . . . you get 30 days **FREE** trial . . . as little as \$5.00 down puts a Midwest radio in your home. Satisfaction guaranteed or money back. Write for new **FREE** catalog.

**SAVE UP TO 50%**

**Sign and mail coupon . . . or, send name and address on postal card . . . NOW! . . . TODAY!**

**50 ADVANCED 1935 FEATURES . . .** and 16 tubes make this radio today's most powerful long distance receiver. The many exclusive Midwest features include: A large airplane-type, modernized dial which is triple calibrated in frequencies, wave lengths and call letters. This exclusive feature, together with simplified tuning guide lights, enables you to tune your Midwest as quickly and accurately as an expert. Among the other features are: Controllable Expansion of Volume, Selectivity-Sensitivity (Micro-Tenuator) . . . Fidel-A-Stat . . . Triple Calibration . . . Pure Silver Wire . . . Ceramic Coil Form . . . Separate Audio Generator . . . Simplified Tuning Guide Lights . . . Compact Synchronized Band Switch . . . Amplified Automatic Volume Control . . . 7 KC Selectivity . . . Power Driver Stage . . . 16 Latest Type Tubes, etc. Read about these and other features in the new 4-color **FREE** Midwest catalog. Fill in and mail coupon **NOW!**

**FREE 36 PAGE 4-Color CATALOG**

We will send you this **FREE** catalog and copies of letters like those shown at left of page. They'll convince you that Midwest radios are sensational values. Try the Midwest for 30 days before you decide. Midwest gives you triple protection with: One-year guarantee, foreign reception guarantee, money-back guarantee.

**MAIL COUPON TODAY! FOR AMAZING 30-DAY FREE TRIAL OFFER AND NEW 1935 CATALOG**

**MIDWEST RADIO CORP., Dept. 724 Cincinnati, Ohio.** Without obligation on my part send me your new **FREE** 1935 catalog and complete details of your liberal 30-day **FREE** trial offer. This is **NOT** an order.

User-Agents Make Easy Extra Money Check Here for Details

Name \_\_\_\_\_  
 Address \_\_\_\_\_  
 Town \_\_\_\_\_ State \_\_\_\_\_

**Hollywood, Calif.—** Until I received my Midwest radio, I had never thought it possible to bring in entertainment from half around the world so clearly. It has been a source of constant pleasure to me.  
**JEAN HARLOW**  
 (Metro-Goldwyn-Mayer Star)

**Amazing All-Wave Reception**  
**Hollywood, Calif.—** I have tried many radios but believe my Midwest the best set I have ever heard. It gives me super foreign reception and new radio adventure. Its performance on all five wave bands absolutely amazes me.  
**RICHARD ARLEN**  
 (Paramount Feature Star)

**Thrilling Foreign Reception**  
**Hollywood, Calif.—** Not until I tried out my Midwest 16 did I really appreciate what radio reception was. It thrills me to bring in distant foreign stations as clearly as local programs.  
**CLAUDETTE COLBERT**  
 (Paramount Star)

**NEW STYLE CONSOLES**



The new, big Midwest 36-page 1935 catalog pictures a complete line of beautiful, artistic de luxe consoles and chassis . . . in four colors . . . a model for every purse. Hand made by master craftsmen, they harmonize beautifully with any furniture arrangement. Write for new **FREE** catalog **TODAY!**

**MIDWEST RADIO CORP.**  
**DEPT. 724 — CINCINNATI, OHIO, U. S. A.**  
 Established 1920 Cable Address Miraco. . . All Codes